

**REGULAR MEETING OF CITY COUNCIL
MARCH 19, 2026 — 5:30 PM
MUNICIPAL COURTROOM
2222 HIGHMARKET STREET
GEORGETOWN, SOUTH CAROLINA
AND LIVESTREAM:**



<https://www.facebook.com/cityoftown/>

Notice of this meeting has been made in accordance with the South Carolina Code of Laws as amended.

- 1. CALL TO ORDER**
- 2. ANNOUNCEMENT CONCERNING ELECTRONIC DEVICES**
- 3. INVOCATION & PLEDGE OF ALLEGIANCE**
- 4. PUBLIC COMMENTS ON CURRENT AGENDA ITEMS**
- 5. INTRODUCTION OF NEW EMPLOYEES**
- 6. PLANNING & COMMUNITY DEVELOPMENT**
 - A. Motion to approve first reading of an ordinance rezoning approximately 8.2 acres, located at 2902 S Island Rd., owned by William Degan, from Low Density Residential (R1) to High Density Residential (R4).**
 - B. Motion to approve first reading of an ordinance amending the City of Georgetown Unified Development Ordinance Article XVIII: Off-Street Parking Sections 1801 and 1810 to re-include parking requirements for office spaces and clarify parking requirements within the Core Commercial (CC) Zoning District.**
- 7. FINANCE**
 - A. Motion to approve a one-year contract extension with Mauldin and Jenkins, LLC to provide audit services.**
- 8. ELECTRIC UTILITIES**
 - A. Motion to approve upgrades to Front St underground infrastructure phase 4 project and award Sumter Utilities in the amount of \$631,489.00.**
- 9. POLICE**
 - A. Motion to Approve a Memorandum of Understanding (MOU) Mutual Aid Narcotics and Vice Enforcement between Georgetown Police Department and Georgetown County Sheriff's Department.**

10. PUBLIC WORKS

- A. Motion to approve the purchase of a garbage truck for the Waste Management division of Public Works from Amick Equipment in the amount of \$377,241.44.**

11. ADMINISTRATION

- A. Motion to approve second reading of an ordinance amending Chapter 2, Article II, Division 2, Sections 2-31 of the Code of Ordinances for the City of Georgetown.**

12. CITY ADMINISTRATOR REPORT

13. MINUTES

- A. Motion to approve minutes of February 19, 2026 council meeting.**

14. UNFINISHED BUSINESS

15. NEW BUSINESS

16. DEPARTMENT MONTHLY REPORTS

A. Electric Department Monthly Report

1. Electric Department February 2026 Report

B. Engineering Department Monthly Report

1. Engineering Department February 2026 Report

C. Finance Department Monthly Report

1. Finance Department Current Project February 2026 Report
2. Finance Department Grant Summary February 2026 Report
3. Finance Department Open PO February 2026 Report
4. Finance Department Vehicle and Heavy Equipment Cost February 2026 Report
5. Finance Department February 2026 Report
6. Finance Department GovDeal February 2026 Report
7. Finance Department Budget Performance January 2026 Report
8. Finance Department HDL Active Businesses February 2026 Report

D. Fire Department Monthly Report

1. Fire Department February 2026 Monthly Report

E. Fleet Services Monthly Report

1. Fleet Services FEBRUARY 2026 Report

F. Human Resources Monthly Report

1. Human Resources Monthly Report February 2026

G. Municipal Court Monthly Report

1. Municipal Court February 2026 Monthly Report
2. Municipal Court February 2026 Cases Filed Report

H. Building, Planning & Community Development Monthly Report

1. Building Department February 2026 Report Statistics
2. Planning and Community Development February 2026 Report Statistics
3. Planning and Community Development February 2026 Monthly Report

I. Police Department Monthly Report

1. Police Department February 2026 Report
2. Police Department February 2026 Report Statistics

J. Public Works Monthly Report

1. Public Works February 2026 Monthly Report

K. Risk Management Monthly Report

1. Risk Management February 2026 Monthly Report

L. Water Utilities Monthly Report

1. Utility Report Monthly
2. February 1, 2026 thru February 28, 2026

17. PUBLIC COMMENTS ON CITY SERVICES, BUSINESS, OR OTHER CITY MATTERS NOT ON THE AGENDA

18. EXECUTIVE SESSION

- A. Motion to adjourn Regular Meeting and enter into Executive Session pursuant to Section 30-4-70(a)(1) to discuss appointments to the City Boards/Commissions and to discuss employment for a position in the Police department.**
- B. Motion to adjourn Executive Session and reconvene Regular Meeting.**
- C. NO FORMAL ACTION WAS TAKEN IN EXECUTIVE SESSION.**

D. City Council may take action on items discussed in Executive Session.

19. ADJOURNMENT

A. Motion to Adjourn the Regular Meeting of City Council.



120 North Fraser Street • Georgetown, SC 29440 • (843) 545-4000

ACTION ITEM

Council Meeting Date:	March 19, 2026
Department:	Planning & Community Development
Issue Under Consideration:	Motion to approve first reading of an ordinance rezoning approximately 8.2 acres, located at 2902 S Island Rd., owned by William Degan, from Low Density Residential (R1) to High Density Residential (R4).
Amount Requested:	N/A
In Current Budget?:	N/A
If not, please explain:	N/A
Financial Impact:	N/A
Points to Consider:	Please see staff report attachment.
Options:	Approve or Deny
Staff Recommendation:	Staff support Planning Commission's recommendation of approval.

Reviews:

Clarissa Tindall	Created/Initiated	Approver
Jennifer Boyer	Approved	Approver
Elise Crosby	Approved	Approver
Scott Whittier	Approved	Approver
Stephanie Buccione	Final Approval	Approver

Attachments:

1. 2902 S Island Rd. CC Staff Report
2. 2902 S Island Rd. Rezoning Additional Documents
3. ORD RZO 8.2 ACRES 2902 S ISLAND TMS#05-0052-009-00-00

MAYOR
JAY DOYLE

CITY ADMINISTRATOR
SCOTT WHITTIER

CITY CLERK
STEPHANIE BUCCIONE



COUNCIL MEMBERS
MAYOR PRO TEMPORE
JESSIE WALKER

BRUCE CARL
ERIN ETHRIDGE
TAMIKA WILLIAMS-OBENG
SHARON MELTON
HOBSON HENRY MILTON

Planning and Community Development
(843) 545-4010

CITY OF GEORGETOWN CITY COUNCIL

MEETING DATES: **First Reading:** March 19, 2026 **Second Reading:** April 16, 2026

AGENDA ITEM: Rezoning: PLZ-2026-0020. Rezoning of approximately 8.2 acres, owned by William Degan, located at 2902 S Island Rd., TMS#: 05-0052-009-00-00, from Low Density Residential (R1), to High Density Residential (R4).

CURRENT STATUS: The parcel is located east of South Island Rd. and west of the unfinished portions of the R4 South Island Landing subdivision. There is one existing structure on the property previously used as a retirement/nursing home.

POINTS TO CONSIDER:

1. This parcel is located within the City of Georgetown service area. Electric, water and sewer are available to this property.
2. Currently, the property is zoned R1, which does not support the potential intended uses of the property for multi-family or group dwelling per the City of Georgetown Unified Development Ordinance Article VI: Provisions Governing Use Districts.
 - a. These uses are allowed under the R4 zoning classification.
3. The existing structure does conform to the area, yard and height requirements for the Public Service Zoning District.
 - a. The existing structure would conform to the area, yard and height requirements for the R4 Zoning District.
4. The parcel in question does conform to the minimum lot size requirements for the R4 Zoning District.
 - a. Required: 6,000 sq ft
 - b. Present: 8.35 acres
5. Adjacent parcels are zoned R4 (High Density Residential) and R1 (Low Density Residential) (*Reference Item 1; Reference Item 2*):
6. This rezoning would be considered an up zoning.
7. The dimensional standards are as follows:

<u>Zoning District</u>	<u>Minimum Lot Size</u>	<u>Front Setback</u>	<u>Side Setback</u>	<u>Rear Setback</u>	<u>Maximum Building Height</u>
<i>Existing R1 Residential</i>	10,000 sq ft	30 ft	10 ft	20 ft	35 ft
<i>Proposed R4 Residential</i>	6,000 sq ft	25 ft	8 ft	10 ft	35 ft

8. The comparison of permitted uses for the existing and proposed zoning classifications are included below (differences highlighted in yellow):

Residential Use Classifications	R1	R4	Conditions
Accessory Dwelling	P	P	
Adult Mini-day Care	C	C	Section 817
Barber Shop			Section 818
Beauty Shop			Section 818
Bed & Breakfast Inn	C	C	Section 809
Church	C	C	Section 818
Courthouse		C	Section 818
Customary General Farming	P	P	
Duplex		C	Section 1007
Eleemosynary Club			Section 818
Fraternal Organization	C	C	Section 1104
Funeral Home		C	Section 1104
Garage Apartment		P	
Group Dwelling		P	
Home Occupation	P	P	
Hospital			
Accessory Building to Hospital			
Library		C	Section 818
Lodges			Section 818
Mini-day Care	C	C	Section 816
Manufactured Home			Section 1006
Multi-Family		C	Section 1005
Multi-level Parking Facility			
Museum		C	Section 818
Non-commercial Accessory Building	P	P	Section 802
Not for Profit Clubs		C	Section 1104
Nursing Home	C	C	Section 814
Offices		C	Section 1104
Park	C	C	Section 818
Post Office		C	Section 818
Public Assembly Hall		C	Section 818
School for General Education	C	C	Section 815
Short-Term Vacation Rental	C	C	Section 1008
Single Family Home	P	P	
Solar Energy System	C	C	Section 828
Substation	C	C	Section 813
Taxi Stand		C	Section 1104
Two Family Dwelling		P	
Water Tower	C	C	Section 812

9. The Future Land Use map (*2040 Comprehensive Plan*) designates this area as Neighborhood Residential and Conservation and Open Space. Surrounding properties are designated as Neighborhood Residential. (*Reference Item 3*).

10. A portion of this property is located within an AE 11 Flood Zone (*Reference Item 4*).

11. . All callers were encouraged to write a letter and/or attend the public hearing to convey their comments to the commission.

12. All rezonings must be heard one (1) time at Planning Commission, and two (2) times at City Council.

PUBLIC INPUT RECEIVED: Public input on this agenda item included comments regarding the definitions in Article III of the Unified Development Ordinance. Concerns were raised that increasing density would increase the value of the land and drive development toward the southern end of the city, that the Future Land Use Map does not address group homes and that residents of Maryville should be notified about all uses permitted in the R4 zoning district, as opposed to R1. An adjacent resident raised concerns about potential changes to the character of the area due to increased development across the City and Georgetown County, as well as increased traffic, speeding, roadway conditions, impacts on wetlands, and the location of the school bus stop in front of the existing structure. Two additional items of public input were submitted by letter and read aloud by staff during public input. One individual stated she had been assured that a homeless shelter would not be permitted at the site and reiterated concerns regarding the bus stop and traffic. The other individual expressed a desire to maintain a quiet neighborhood and opposed higher-density development.

PLANNING COMMISSION DISCUSSION: The Commission questioned staff about the designation of surrounding residential areas, noting that the existing number of homes per acre visually appeared more consistent with R4 zoning than the current R1 designation. Staff explained that in older cities, it is common to find existing residential areas, lots, or structures with densities higher than the current zoning allows. The Commission also asked about wetlands on the property and whether they could be developed. Staff indicated that wetlands are present on the northern portion of the site and that the City currently has no wetland regulations outside of Planned Development districts. However, any wetland alteration would require approval from the U.S. Army Corps of Engineers and compliance with their regulations.

The Commission inquired how many lots the applicant could create under R4 zoning. Staff explained that they could not provide an exact number, as subdividing the property would require new roadways and infrastructure, the layout of which would determine the number of lots. Staff also clarified that the property owner has not indicated any intention to subdivide. The applicant/agent confirmed their plan is to use the facility as a veteran's home, which would fall under the "Group Home" or "Multi-Family" permitted uses in the R4 district, and reiterated that they do not intend to subdivide the property.

A commissioner asked whether keeping the property R1 would prevent the applicant's proposed use. The applicant noted that staff advised a veteran's home would not qualify as an "assisted living facility" and would only be allowed under "Group Dwelling" or "Multi-Family" uses, making rezoning necessary. Staff acknowledged that this conversation did take place and that the applicants' statements were correct. When asked about the remaining undeveloped portion of the property, the applicant stated they intend to leave it undeveloped. The Commission also inquired about potential traffic impacts, and the applicant responded that a veterans home is expected to generate approximately eight vehicle trips per day, which should not significantly impact traffic in the area.

A motion was made to recommend approval of the application as submitted with no conditions. This motion passed with a vote of 5-1.

REFERENCE MATERIALS

REFERENCE ITEM 1: Tax map. *Please note that locations of parcel lines may not be entirely accurate.*

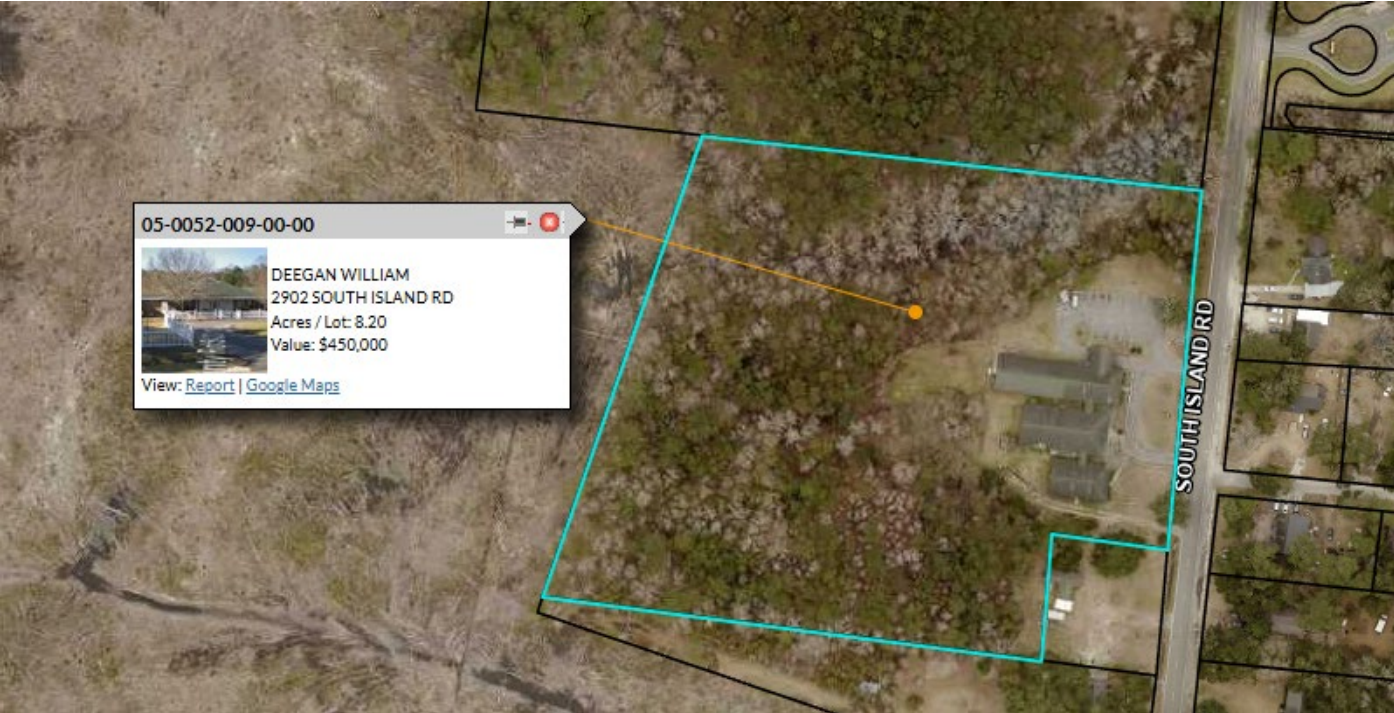

REFERENCE ITEM 2: Zoning map.



Parcel View

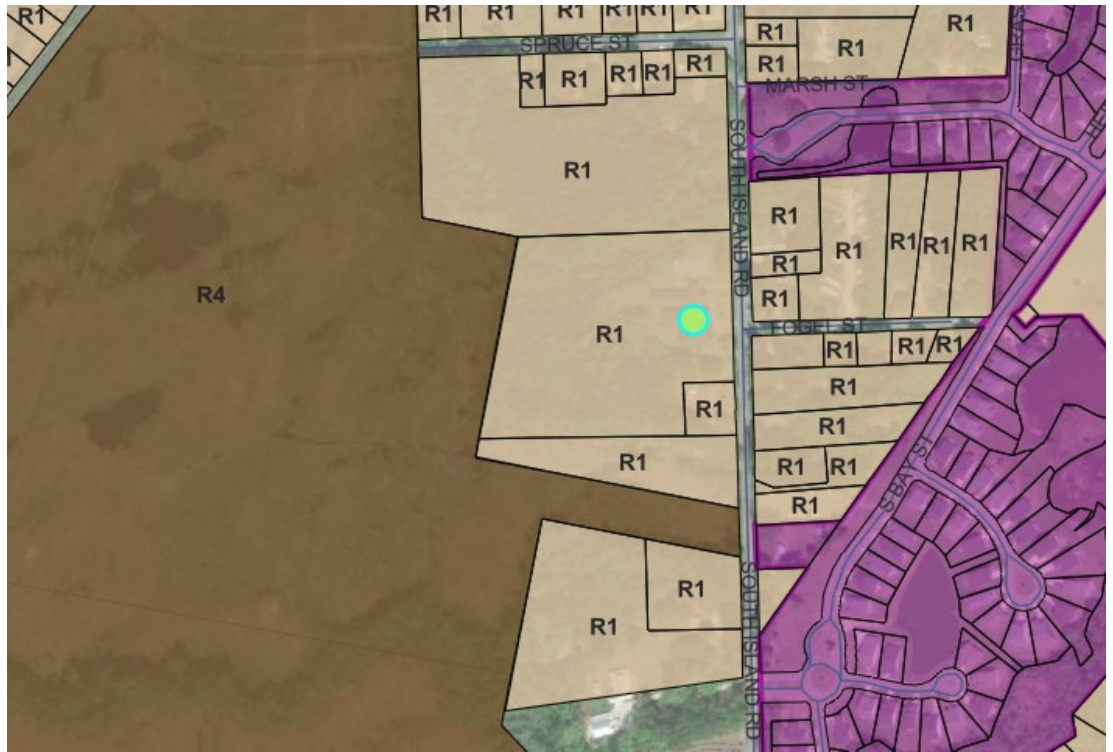

Block View

REFERENCE ITEM 3: Future land use designation.

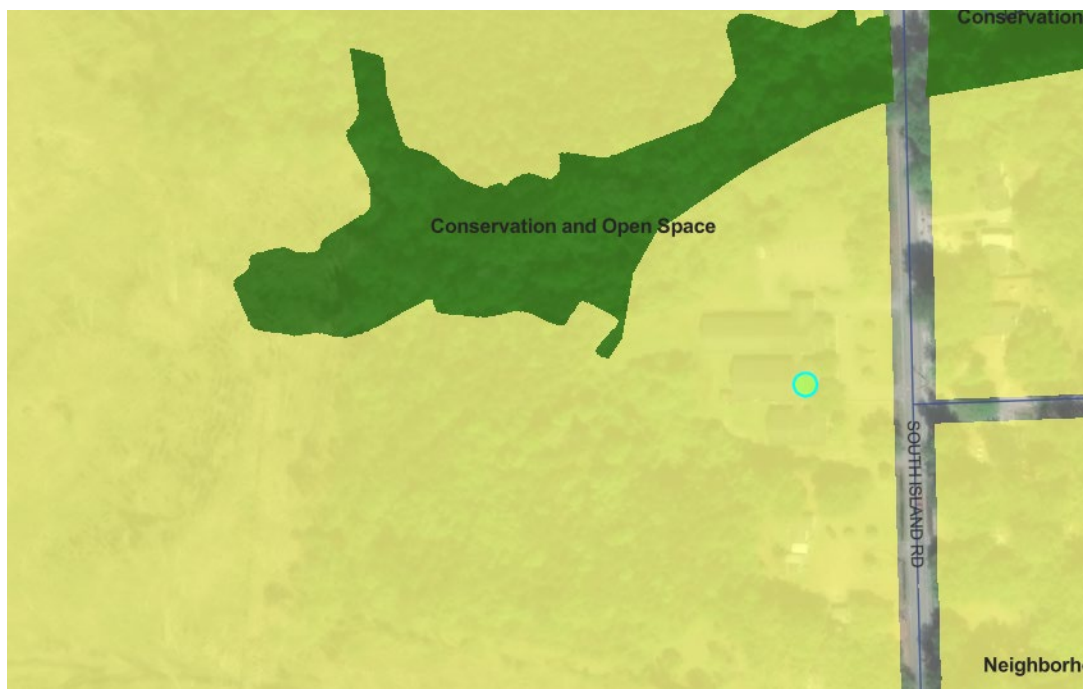

Parcel view

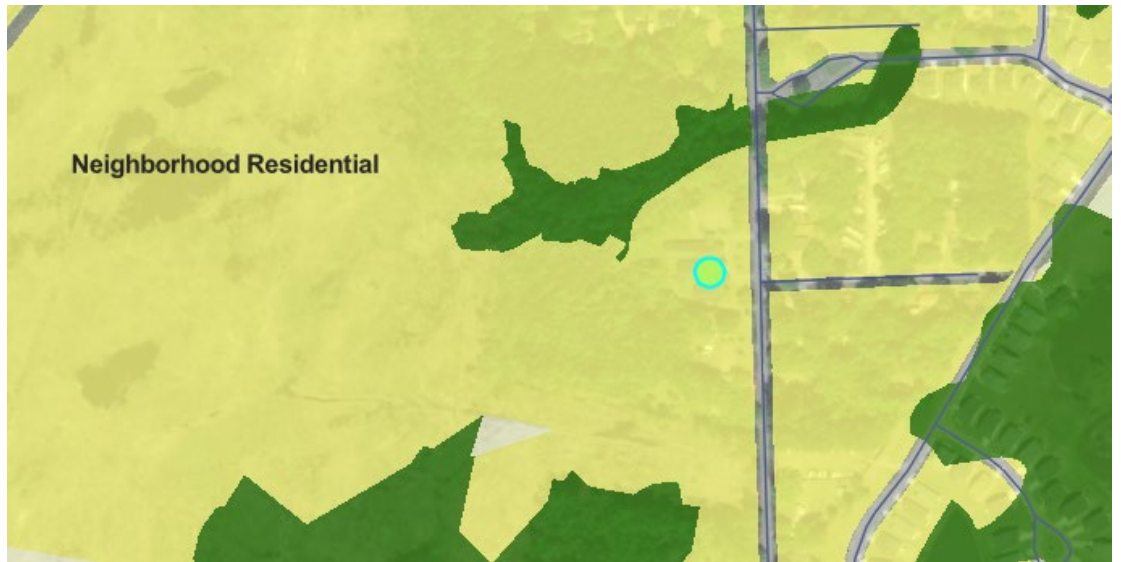

Block View

REFERENCE ITEM 4: FEMA Flood Map.

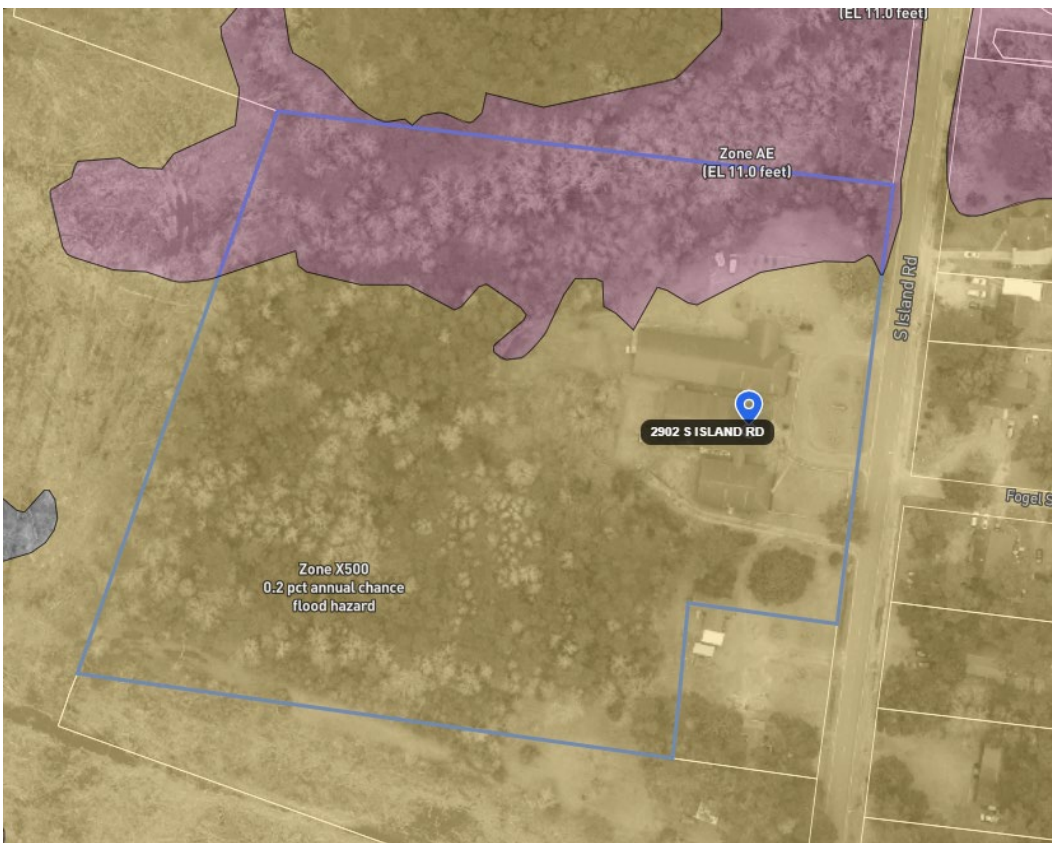

Flood zone	AE
Coastal A zone	No
Supplemental Coastal A	No
In Floodway	No
In CBRS	No
In OPA	No
Base Flood Elevation	11.0'
Design Flood Elevation	13.0'

PLZ-2026-0020

Prepared by:
Benjamin E Grimsley
SMITH ROBINSON
PO Box 11682
Columbia, SC 29211
title not examined by preparer

STATE OF SOUTH CAROLINA)
)
COUNTY OF GEORGETOWN)

**TITLE TO REAL ESTATE
(Limited Warranty Deed)**

KNOW ALL MEN BY THESE PRESENTS that **Midwest Regional Bank** ("Grantor"), for and in consideration of the sum of Four Hundred Eighty-Five Thousand and no/100 Dollars (\$485,000.00) in hand paid to it by **William Deegan** ("Grantee"), the receipt and sufficiency of which is hereby acknowledged, has granted, bargained, sold, and released, and by these presents does grant, bargain, sell, and release subject to the easements, restrictions, reservations and conditions set forth in the legal description below, unto the Grantee, his heirs and assigns, the following described real property (the "Premises"):

All and singular that certain parcel or tract of land, together with the improvements thereon, situate, lying and being in the City and County of Georgetown, State of South Carolina, and designated on a Plat as (8.26) acres, being a portion of Lot 9, Maryville Farms, West of South Island Road, prepared by Wendell C. Powers, R.L.S., dated October 17, 1986, and recorded in Plat Book 7, at Page 453, and further shown on a revised Plat by Wendell C. Powers, R.L.S., dated December 23, 1997, and recorded in the R.M.C. Office for Georgetown County, South Carolina, in Plat Book 258, at Page 8A, which plat is by reference incorporated herein and made a part and parcel hereof.

Being the same property conveyed to Midwest Regional Bank by deed of Joe M. Crosby, Master-in-Equity for Georgetown County, dated April 29, 2025 and recorded on June 11, 2025 in the office of the Register of Deeds for Georgetown County in Book 4842 at Pages 295-299.

TMS #: 05-0052-009-00-00

Property Address: 2902 S. Island Road
Georgetown, South Carolina 29440

Grantee's Address: 5502 W. 138th St.
Hawthorne, California 90250

THIS CONVEYANCE IS MADE SUBJECT TO all other easements and

Menu JLL Appraisal_Report_29... X + Create

Try PDF Spaces All tools Edit Convert E-Sign

Find text, tools, or help Ask AI Assistant

Legal Constraints Analysis

Zoning Map

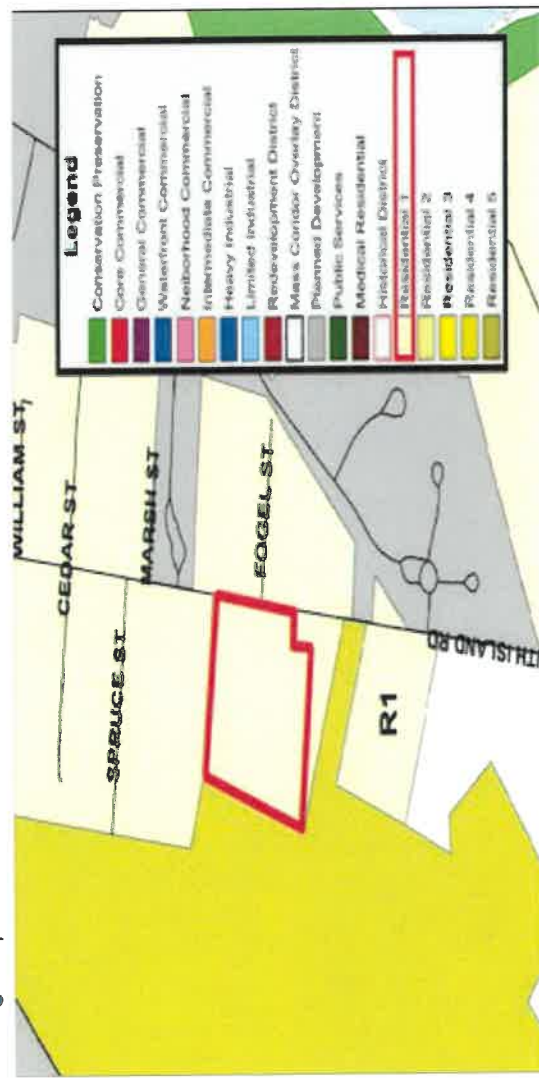

According to the city of Georgetown, the subject is currently zoned R1 - Residential 1 (Low Density Residential). A description of the zoning classification is presented below:



56 207 < >

57

8.50 x 11.00 in

Search

74°F Sunny

11:19 AM 1/15/2026

PLZ-2020-0020

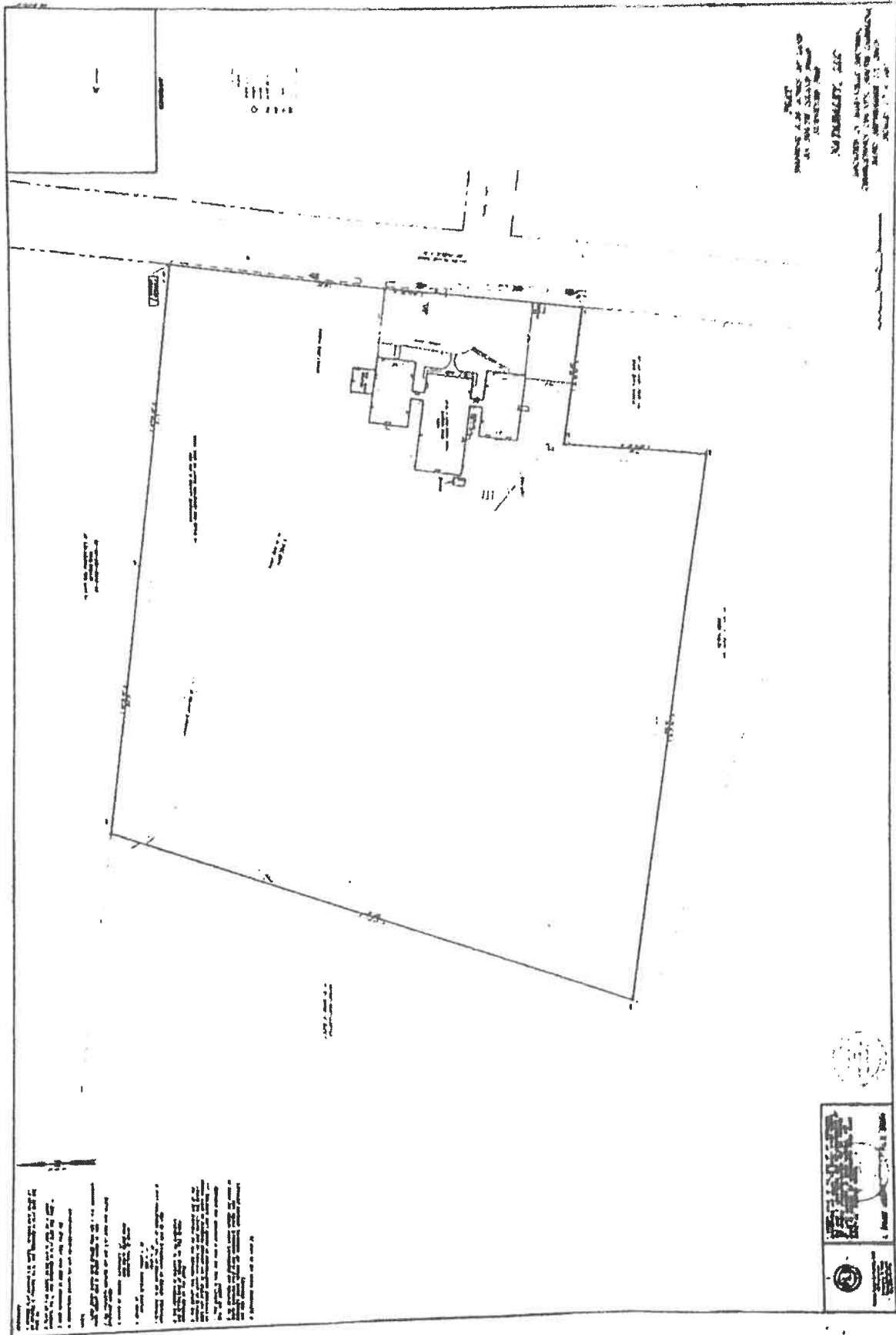

9/17/20

AN ORDINANCE REZONING APPROXIMATELY 8.2 ACRES, LOCATED AT 2902 S Island Rd., OWNED BY William Degan, FROM Low Density Residential (R1) TO High Density Residential (R4)

WHEREAS, pursuant to Title 6, Chapter 29 of the Code of Laws of South Carolina, the City of Georgetown enacted the Unified Development Ordinance of the City of Georgetown, South Carolina; and

WHEREAS, Article XXIX, Section 2900 of the Unified Development Ordinance of the City of Georgetown provides that the Unified Development Ordinance may be amended from time to time by the Mayor and City Council; and

WHEREAS, On January 16, 2026, the City of Georgetown received an application from the owner to rezone the parcel(s) having County Tax Map No. 05-0052-009-00-00 from Low Density Residential (R1) to High Density Residential (R4); and

WHEREAS, the Planning Commission of the City of Georgetown, South Carolina held a public hearing to receive public input regarding the rezoning request; and

WHEREAS, following the public hearing on February 24, 2026, the Planning Commission heard a motion to approve rezoning, which passed 5-1; and

WHEREAS, the Mayor and City Council of the City of Georgetown have determined that the rezoning is consistent with the Future Land Use Map and that the zoning boundaries as shown on the Official Zoning Map be revised and amended as follows:

Rezoning from Low Density Residential (R1) to High Density Residential (R4), property totaling approximately 8.2 acres located on S Island Rd., identified by the Georgetown County Tax Map as TMS# (05-0052-009-00-00).

For a more specific description of said property, please see attached map.

NOW, THEREFORE, BE IT ORDAINED by the Mayor and City Council of the City of Georgetown, in Council duly assembled, that the Official Zoning Map of the City of Georgetown be amended by revising and amending the zoning boundaries of the Official Zoning Map, together with all explanatory matter herein as follows:

Rezoning from **Low Density Residential (R1)** to **High Density Residential (R4)**, property totaling approximately **8.2** acres located at **2902 S Island Rd.**, identified by the Georgetown County Tax Map as TMS# (**05-0052-009-00-00**).

BE IT FURTHER ORDAINED, that such changes shall be made on the Official Zoning Map. All ordinances or parts of ordinances inconsistent with this Ordinance are hereby repealed to the extent of such inconsistency.

ATTEST:

Stephanie Buccione, City Clerk

First Reading: _____

Second Reading: _____

Jay Doyle, Mayor

Approved as to Form:

Elise F. Crosby, City Attorney



120 North Fraser Street • Georgetown, SC 29440 • (843) 545-4000

ACTION ITEM

Council Meeting Date:	March 19, 2026
Department:	Planning & Community Development
Issue Under Consideration:	Motion to approve first reading of an ordinance amending the City of Georgetown Unified Development Ordinance Article XVIII: Off-Street Parking Sections 1801 and 1810 to re-include parking requirements for office spaces and clarify parking requirements within the Core Commercial (CC) Zoning District.
Amount Requested:	N/A
In Current Budget?:	N/A
If not, please explain:	N/A
Financial Impact:	N/A
Points to Consider:	Please see staff report attachment.
Options:	Approve or Deny.
Staff Recommendation:	Staff support Planning Commission's recommendation of approval.

Reviews:

Clarissa Tindall	Created/Initiated	Approver
Jennifer Boyer	Approved	Approver
Elise Crosby	Approved	Approver
Scott Whittier	Approved	Approver
Stephanie Buccione	Final Approval	Approver

Attachments:

1. ORD TXT AMEND ART XVIII PARKING

2. Parking Text Amendment CC Staff Report
3. TXT AMEND ART XVIII PARKING COMPARISON
4. Screenshot of former ordinance

AN ORDINANCE AMENDING THE CITY OF GEORGETOWN UNIFIED DEVELOPMENT ORDINANCE ARTICLE XVIII: OFF-STREET PARKING SECTIONS 1801 AND 1810 TO INCLUDE PARKING REQUIREMENTS FOR OFFICE SPACES AND CLARIFY PARKING REQUIREMENTS WITHIN THE CORE COMMERCIAL (CC) ZONING DISTRICT

WHEREAS, pursuant to Title 6, Chapter 29 of the Code of Laws of South Carolina, the City of Georgetown enacted the Unified Development Ordinance of the City of Georgetown, South Carolina; and

WHEREAS, Article XXIX, Section 2900 of the Unified Development Ordinance of the City of Georgetown provides that the Unified Development Ordinance may be amended from time to time by the Mayor and City Council; and

WHEREAS, On January 17, 2026, the City of Georgetown Building and Planning Staff requested a modification to the ordinance to reinstate parking standards for offices that were inadvertently omitted during the adoption of the Unified Development Ordinance and to clarify parking requirements for the Core Commercial (CC) Zoning District as a short-term measure until a more comprehensive review of parking is completed; and

WHEREAS, the Planning Commission of the City of Georgetown, South Carolina held a public hearing to receive public input regarding the text amendment request; and

WHEREAS, following the public hearing on February 24, 2026, the Planning Commission heard a motion to approve the text amendment, which passed 6-0; and

WHEREAS, the Mayor and City Council of the City of Georgetown have determined that the text amendment is consistent with the Comprehensive Plan;

NOW, THEREFORE, BE IT ORDAINED by the Mayor and City Council of the City of Georgetown, in Council duly assembled, that Article XVIII Off-Street Parking of the official City of Georgetown Unified Development Ordinance be amended at Sections 1801 and 1810 as follows:

1801 Off-street parking in the Core Commercial District.
 The off-street parking requirements in this Ordinance shall not apply to retail, restaurant, museum, barber or beauty shop uses in the Core Commercial District. The Zoning Administrator shall determine the off-street parking requirements for other uses in the Core Commercial District.

1810 Parking Space Requirement Table.

Use	Parking Requirement
<i>Professional Services</i>	
ATM (Separate building located on same parcel)	One space per machine
ATM (Separate building located on different parcel)	Two spaces per machine
Banks and financial institutions	Three waiting spaces per drive-in service unit plus one space per employee at largest shift, plus one space per 400 sq ft of gross floor area
Offices (excluding medical)	One space per 400 sq ft of floor space

BE IT FURTHER ORDAINED, that such changes shall be made to the Official City of Georgetown Unified Development Ordinance. All ordinances or parts of ordinances inconsistent with this Ordinance are repealed to the extent of such inconsistency.

Stephanie Buccione, City Clerk

First Reading: _____

Second Reading: _____

Jay Doyle, Mayor

Approved as to Form:

Elise F. Crosby, City Attorney

MAYOR
JAY DOYLE

CITY ADMINISTRATOR
SCOTT WHITTIER

CITY CLERK
STEPHANIE BUCCIONE



COUNCIL MEMBERS
MAYOR PRO TEMPORE
JESSIE WALKER

BRUCE CARL
ERIN ETHRIDGE
TAMIKA WILLIAMS-OBENG
SHARON MELTON
HOBSON HENRY MILTON

Planning and Community Development
(843) 545-4010

CITY OF GEORGETOWN CITY COUNCIL

MEETING DATES: **First Reading:** March 19, 2026 **Second Reading:** April 16, 2026

AGENDA ITEM: PLZ-2026-0023: UDO Text Amendment. A request from the City of Georgetown Building & Planning Department to amend the City of Georgetown Unified Development Ordinance Article XVIII: Off-Street Parking, Sections 1801 and 1810.

CURRENT STATUS: The existing ordinance (Article XVIII: Off-Street Parking, Sections 1801) exempts all permitted uses in the Core Commercial zoning district from providing any parking. The existing ordinance (Article XVIII: Off Street Parking, Section 1810) when adopted accidentally excluded parking provisions for offices, staff are proposing these standards be re-introduced into the UDO.

EXISTING ORDINANCE:

1801 Off-street parking in the Core Commercial District.

The off-street parking requirements in this Ordinance shall not apply to permitted uses in the Core Commercial District. The Zoning Administrator shall determine the off-street parking requirements for other uses in the Core Commercial District.

1810 Parking Space Requirements Table.

Does not currently include standards for offices

PROPOSED ORDINANCE:

1801 Off-street parking in the Core Commercial District.

The off-street parking requirements in this Ordinance shall not apply to **permitted retail, restaurant, museum, barber or beauty shop** uses in the Core Commercial District. The Zoning Administrator shall determine the off-street parking requirements for **other conditional** uses in the Core Commercial District.

1810 Parking Space Requirements Table.

Use	Parking Requirement
<i>Professional Services</i>	
Offices (excluding medical)	One space per 400 sq ft of floor space

POINTS TO CONSIDER:

- Properties within the Core Commercial zoning district may be considered affected by the text amendment proposed for Section 1801.
- Staff would not consider offices (city wide) to be affected by the text amendment proposed for Section 1810 as the standards proposed were established in the Zoning Ordinance and accidentally excluded during the UDO adoption.

3. A red-lined copy of the proposed ordinance updates has been attached for reference purposes (Reference Document 3)
4. All callers were encouraged to write a letter and/or attend the public hearing to convey their comments to the commission.
5. All text amendments must be heard one (1) time at Planning Commission, and two (2) times at City Council.

PUBLIC INPUT RECEIVED: No public input was received for this item.

PLANNING COMMISSION DISCUSSION: Commissioners asked how this amendment would affect changes in the use of existing buildings. Staff explained that, depending on the specific use, off-street parking may be required. Staff provided the following example: many buildings in the area have multiple residential units on upper floors. Under the current ordinance, these units are not required to provide additional parking (*exempted under Article IX: Nonconforming Use Standards*) unless a new unit is added or the use of an existing unit is altered. The proposed amendment would apply a similar approach to other uses within the Core Commercial zoning district. Staff also noted that the ordinance allows for parking to be accommodated off-site, which could reduce any potential burden created by the expanded regulations.

The Commission asked for staff to confirm that this off-site parking allowance had been granted to the new hotel. Staff clarified that while the hotel does rent parking spaces from an adjacent parcel and from the City at the end of Queen Street, this was done voluntarily, as the current ordinance does not require off-street parking for hotels, since hotels are a permitted use rather than a conditional use under the existing regulations.

A motion was made to recommend approval of this item as submitted with no conditions. This motion passed unanimously with a vote of 6-0.

Existing Ordinance:

1801 Off-street parking in the Core Commercial District.

The off-street parking requirements in this Ordinance shall not apply to permitted uses in the Core Commercial District. The Zoning Administrator shall determine the off-street parking requirements for conditional uses in the Core Commercial District.

1810 Parking Space Requirement Table.

No standards are currently included for non-medical offices.

Redlined:

1801 Off-street parking in the Core Commercial District.

The off-street parking requirements in this Ordinance shall not apply to ~~permitted~~ retail, restaurant, museum, barber or beauty shop uses in the Core Commercial District. The Zoning Administrator shall determine the off-street parking requirements for ~~other conditional~~ uses in the Core Commercial District.

1810 Parking Space Requirement Table.

Use	Parking Requirement
<i>Professional Services</i>	
ATM (Separate building located on same parcel)	One space per machine
ATM (Separate building located on different parcel)	Two spaces per machine
Banks and financial institutions	Three waiting spaces per drive-in service unit plus one space per employee at largest shift, plus one space per 400 sq ft of gross floor area
Offices (excluding medical)	One space per 400 sq ft of floor space

Proposed Ordinance:

1801 Off-street parking in the Core Commercial District.

The off-street parking requirements in this Ordinance shall not apply to retail, restaurant, museum, barber or beauty shop uses in the Core Commercial District. The Zoning Administrator shall determine the off-street parking requirements for other uses in the Core Commercial District.

1810 Parking Space Requirement Table.

Use	Parking Requirement
<i>Professional Services</i>	
ATM (Separate building located on same parcel)	One space per machine
ATM (Separate building located on different parcel)	Two spaces per machine
Banks and financial institutions	Three waiting spaces per drive-in service unit plus one space per employee at largest shift, plus one space per 400 sq ft of gross floor area
Offices (excluding medical)	One space per 400 sq ft of floor space

	Use	Parking Requirement
Professional Services	ATM (Separate building located on same parcel)	One space per machine
	ATM (Separate building located on different parcel)	Two spaces per machine
		Three waiting spaces per drive-in service unit plus one space per employee at largest shift, plus one space per 100 sq ft of gross floor area
	Banks and financial institutions	
	Offices (excluding medical)	One space per 400 sq ft of floor space



120 North Fraser Street • Georgetown, SC 29440 • (843) 545-4000

ACTION ITEM

Council Meeting Date:	March 19, 2026
Department:	Finance
Issue Under Consideration:	Motion to approve a one-year contract extension with Mauldin and Jenkins, LLC to provide audit services.
Amount Requested:	\$50,000.00
In Current Budget?:	NO
If not, please explain:	Will be budgeted in FY 2027
Financial Impact:	N/A for FY 2026
Points to Consider:	<p>The City of Georgetown entered into a new contract with Mauldin and Jenkins, LLC for financial statement preparation and audit that was approved by Council on May 19, 2022. The three-year contract term ended for the 2025 financial statements, but the contract allowed for an extension for up to 2 years. With the recent changes and ongoing challenges with the City's ERP software and with some upcoming significant new reporting requirements for financial statement preparation, we feel that it would be prudent to extend the Mauldin and Jenkins, LLC contract to include the FY 2026 financial statement preparation and audit.</p> <p>We will need to plan to rebid a new three-year contract, with optional extensions, beginning with the 2027 financial statement preparation and audit.</p>
Options:	Approve/Disapprove
Staff Recommendation:	Approve

Reviews:

Kathy Vermeland	Created/Initiated	Approver
Kathy Vermeland	Approved	Approver
Kathy Vermeland	Approved	Approver
Elise Crosby	Approved	Approver
Scott Whittier	Approved	Approver
Stephanie Buccione	Final Approval	Approver

Attachments:

1. City of Georgetown Cost Quote



Going
Further.

City of Georgetown, South Carolina

Proposal to Provide Audit Services

Cost Quote - Auditing Services

Fiscal Year June 30, 2026

Mauldin & Jenkins Certified Public Accountants

Contact Person: David Irwin, CPA, Partner

Phone: (800) 277-0050

Email: dirwin@mjcpa.com

508 Hampton Street, 1st Floor

Columbia, SC 29201

mjcpa.com





VISION

To be a trusted advisor, earning trust and building respect through our consistent commitment to sustainable excellence, leadership, and integrity.

*Over 725 Governmental Units
Served Nationally*

INSIDE

public accounting

**TOP 100
FIRMS
2025**

Going Further.



February 11, 2026

COST QUOTE

To the Honorable Members of City Council
City of Georgetown, South Carolina
1134 North Fraser Street
Georgetown, South Carolina 29440

Attn: Kathy Vermeland, Director of Finance

We are quite pleased at your request for Mauldin & Jenkins to provide a cost quote to continue to provide independent auditing services to the City of Georgetown, South Carolina (the “City”). As professionals serving the public sector, we believe our firm is eminently qualified to serve the City.

Mauldin & Jenkins is the leader in auditing state and local governments in the Southeast. This leadership was not attained by us viewing all audits the same. Rather, this was achieved by recognizing that we are an important part of the City’s success, with our objective being to ensure that accurate information is reported in a timely fashion to the governing board, management, and citizens.

Given the complexities of the City’s financial operations and the ongoing significant changes in accounting standards, we feel that it is very important that you select an auditing firm that is **focused and experienced** in the governmental industry. We differentiate ourselves from our peers via:

❖ **Experience with Governments.** As auditors for more governments in the Southeast than any other firm, our professionals are thoroughly versed in the complex governmental arena, and have consistently provided the highest quality of service to our government clients. We serve:

- **725+ state and local governments across the Southeastern U.S.A.**
- **175+ water & sewer systems,**
- 181 governments awarded the GFOA's and, or ASBO's Financial Reporting Certificates.
- 225+ of Single Audits as required by the Uniform Guidance.
- **Current auditors of more Cities in South Carolina than any other firm.**

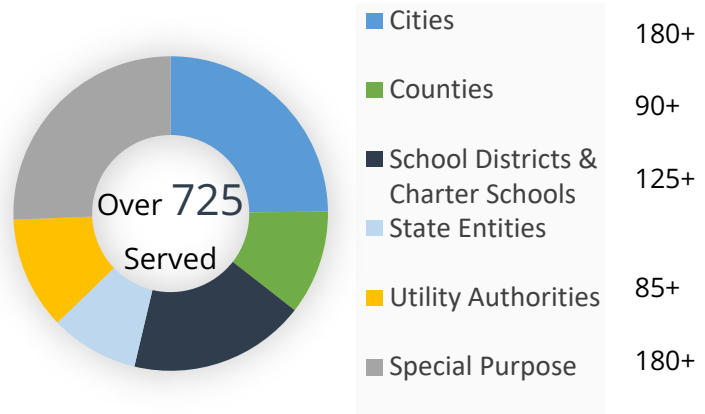

Mauldin & Jenkins provides over 155,000 hours of service to over 725 governmental units in the Southeast on an annual basis utilizing over 150 professionals.

Firm Qualifications and Experience

Organization and Size – Regional Firm

Mauldin & Jenkins was formed in approximately 1918 and has been actively engaged in governmental auditing since its inception. Mauldin & Jenkins is one of the largest certified public accounting firms in the Southeast and in the U.S.A., and a leading provider of audit and accounting services. Mauldin & Jenkins serves clients whose operations span the entire U.S.A. Mauldin & Jenkins is considered to be a large regional firm with offices in the following communities:



- **Albany, GA**
- **Alpharetta, GA**
- **Athens, AL**
- **Atlanta, GA**
- **Birmingham, AL**
- **Bradenton, FL**
- **Chattanooga, TN**
- **Columbia, SC**
- **Florence, AL**
- **Huntsville, AL**
- **Macon, GA**
- **Raleigh, NC**
- **Sarasota, FL**
- **Savannah, GA**

Other key information relative to the size and experience of Mauldin & Jenkins is as follows:

- **515,000** - approx. total hours of service provided annually to clients of the Firm
- **155,000** - approx. total hours of service provided annually to governmental clients
- **55%** - percentage of governmental practice as compared to Firm's attestation practice
- **31%** - percentage of governmental practice as compared to Firm's overall practice
- **725** - approx. total governmental entities served in past three (3) years
- **540** - total number of Firm personnel
- **77** - total number of Firm partners
- **25** - total number of full-time governmental partners & directors
- **20** - total number of full-time governmental managers
- **150** - total number of professionals with current governmental experience



Governments Served in the Past Three Years

Perhaps the greatest indicator of our reliability as a professional service provider to state and local governments is our list of governmental clients.

The following governmental client listings are provided to demonstrate Mauldin & Jenkins' vast experience serving the governmental sector, and these listings are broken down by type of governmental unit, and the respective listings represents clients we have served in the past three years (and not over a lifetime).

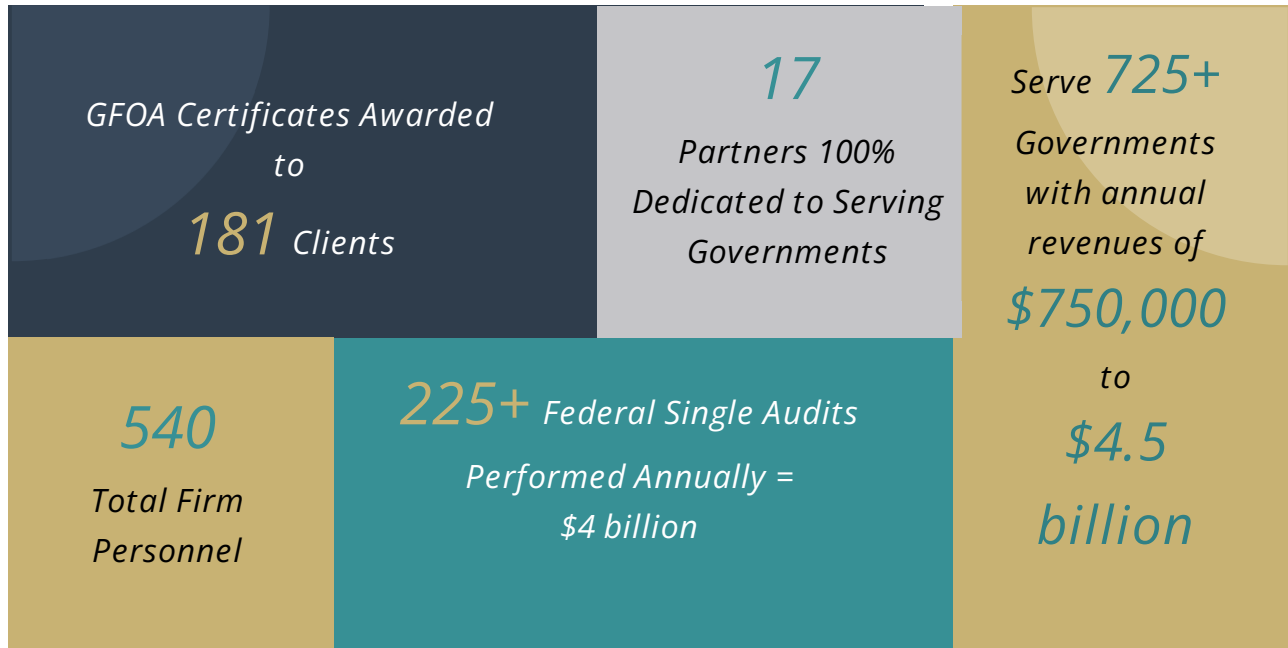



Cities. Cities we have served within the past three years:

Georgia		50) Kingsland	100) Valdosta	144) Jacksonville
1) Albany	51) LaGrange	101) Villa Rica	145) Rocky Mount	
2) Alpharetta	52) Lake Park	102) Waycross	146) Selma	
3) Americus	53) Lawrenceville	103) West Point	147) Zebulon	
4) Ashburn	54) Leesburg	104) Willacoochee	148) Wilkesboro	
5) Atlanta	55) Lilburn			
6) Austell	56) Lone Oak	Alabama / Mississippi	South Carolina	
7) Avondale Estates	57) Lyons	105) Athens, AL	149) Aiken	
8) Bainbridge	58) Manchester	106) Huntsville, AL	150) Beaufort	
9) Baldwin	59) Mansfield	107) Tuscaloosa, AL	151) Bluffton	
10) Ball Ground	60) Milledgeville	108) Gulfport, MS	152) Cayce	
11) Barnesville	61) Milner	109) Meridian, MS	153) Chapin	
12) Bloomingdale	62) Milton	110) Prattville, AL	154) Charleston	
13) Brookhaven	63) Monroe	111) Sheffield, AL	155) Clemson	
14) Brunswick	64) Morrow		156) Clinton	
15) Butler	65) Nashville	Florida	157) Clover	
16) Byron	66) Newton	112) Apopka	158) Fountain Inn	
17) Cartersville	67) Norcross	113) Atlantis	159) Hanahan	
18) Cedartown	68) Oxford	114) Callaway	160) Hardeeville	
19) Centerville	69) Palmetto	115) Clewiston	161) Hemingway	
20) Chamblee	70) Peachtree City	116) Crystal River	162) Hilton Head Island	
21) Chattahoochee Hills	71) Peachtree Corners	117) Destin	163) Hollywood	
22) Clarkston	72) Pearson	118) Gulf Stream	164) Georgetown	
23) College Park	73) Perry	119) Fernandina Beach	165) Greenwood	
24) Colquitt	74) Pooler	120) Ft. Myers Beach	166) Goose Creek	
25) Conyers	75) Powder Springs	121) Haines City	167) Johnsonville	
26) Cordele	76) Port Wentworth	122) Hallandale Beach	168) Kiawah Island	
27) Covington	77) Reynolds	123) Indiantown	169) Mount Pleasant	
28) Dacula	78) Richmond Hill	124) Islamorada	170) North Augusta	
29) Dalton	79) Riverdale	125) Juno Beach	171) North Charleston	
30) Darien	80) Rockmart	126) Jupiter Inlet Colony	172) Orangeburg	
31) Decatur	81) Rome	127) Jupiter Island	173) Pamplico	
32) Doraville	82) Roswell	128) LaBelle	174) Rock Hill	
33) Douglasville	83) Sandy Springs	129) Lake Placid	175) Seabrook Island	
34) Duluth	84) Savannah	130) Longboat Key	176) Seneca	
35) Dunwoody	85) Sharpsburg	131) Marco Island	177) Summerville	
36) Fairburn	86) Social Circle	132) Naples	178) Winnsboro	
37) Fayetteville	87) South Fulton	133) New Port Richey		
38) Flovilla	88) St. Marys	134) North Port	Tennessee	
39) Forest Park	89) Stockbridge	135) Palmetto	179) Bristol	
40) Forsyth	90) Stonecrest	136) Plant City	180) Clarksville	
41) Garden City	91) Suwanee	137) Tarpon Springs	181) Jackson	
42) Grovetown	92) Temple	138) Tequesta	182) Lebanon	
43) Griffin	93) Thunderbolt	139) Wildwood	183) Morristown	
44) Hapeville	94) Tifton	140) Winter Haven		
45) Hinesville	95) Toccoa		Iowa	
46) Holly Springs	96) Tucker	North Carolina	184) Dubuque	
47) Jefferson	97) Turin	141) Black Mountain	185) West Des Moines	
48) Johns Creek	98) Tybee Island	142) Garner		
49) Kennesaw	99) Union City	143) Hendersonville		



Water & sewer operations. Below is a listing of water/sewer operations we have served within the past three years:

- | | | |
|-----------------------------|----------------------------|-----------------------------|
| 1) Aiken County | 46) City of Goose Creek | 91) City of Stockbridge |
| 2) Athens-Clarke County | 47) City of Griffin | 92) City of Suwanee |
| 3) Augusta-Richmond Co. | 48) City of Gulfport | 93) City of Thomasville |
| 4) Barrow County | 49) City of Gulf Stream | 94) City of Thunderbolt |
| 5) Berkeley County, SC | 50) City of Haines City | 95) City of Tifton |
| 6) Bertie County | 51) City of Hendersonville | 96) City of Toccoa |
| 7) Calhoun County | 52) City of Hinesville | 97) City of Tuscaloosa |
| 8) Camden County | 53) City of Islamorada | 98) City of Tybee Island |
| 9) Chatham County | 54) City of Jackson | 99) City of Union City |
| 10) City of Aiken | 55) City of Jacksonville | 100) City of Valdosta |
| 11) City of Albany | 56) City of Jefferson | 101) City of Villa Rica |
| 12) City of Americus | 57) City of Johnsonville | 102) City of Wildwood |
| 13) City of Arcadia | 58) City of Kingsland | 103) Columbia Co. |
| 14) City of Ashburn | 59) City of Lagrange | 104) Crisp County |
| 15) City of Bainbridge | 60) City of Lake Placid | 105) DeKalb County |
| 16) City of Ball Ground | 61) City of Lawrenceville | 106) Floyd County |
| 17) City of Barnesville | 62) City of Lebanon | 107) Forsyth County |
| 18) City of Bloomingdale | 63) City of Leesburg | 108) Gates County |
| 19) City of Bradenton | 64) City of Long Boat Key | 109) Greene County |
| 20) City of Brunswick | 65) City of Manchester | 110) Halifax County |
| 21) City of Butler | 66) City of Mansfield | 111) Lee County |
| 22) City of Byron | 67) City of Marco Island | 112) Liberty County |
| 23) City of Callaway | 68) City of Milledgeville | 113) Lincoln County |
| 24) City of Canton | 69) City of Monroe | 114) McIntosh County |
| 25) City of Cartersville | 70) City of Morristown | 115) Mitchell County |
| 26) City of Cayce | 71) City of Naples | 116) Montgomery County |
| 27) City of Cedartown | 72) City of North Augusta | 117) Monroe County |
| 28) City of Clarksville | 73) City of North Port | 118) Moore County |
| 29) City of Clemson | 74) City of Palmetto | 119) Orange County |
| 30) City of Clinton | 75) City of Perry | 120) Orangeburg County |
| 31) City of Clover | 76) City of Plant City | 121) Paulding County |
| 32) City of College Park | 77) City of Pooler | 122) Richland County, SC |
| 33) City of Colquitt | 78) City of Port Wentworth | 123) Rockdale County |
| 34) City of Conyers | 79) City of Powder Springs | 124) Spalding County |
| 35) City of Cooper City | 80) City of Reynolds | 125) Talbot County |
| 36) City of Cordele | 81) City of Richmond Hill | 126) Taylor County |
| 37) City of Covington | 82) City of Rock Hill, SC | 127) Walton County |
| 38) City of Crystal River | 83) City of Rockmart | 128) Town of Black Mountain |
| 39) City of Fairburn | 84) City of Rocky Mount | 129) Town of Chapin |
| 40) City of Fayetteville | 85) City of Rome | 130) Town of Hemingway |
| 41) City of Fernandina | 86) City of Roswell | 131) Town of Pamplico |
| 42) City of Forsyth | 87) City of Savannah | 132) Town of Selma |
| 43) City of Ft. Myers Beach | 88) City of Seneca, SC | 133) Town of Wilkesboro |
| 44) City of Garden City | 89) City of Social Circle | 134) Town of Winnsboro |
| 45) City of Georgetown | 90) City of St. Marys | 135) Village of Tequesta |



Additional Information of Value Added Services

Upcoming GASB Statements

As has been the case for the past 10 years, GASB has issued several other new pronouncements which will be effective in future years. The following is a brief summary of the new standards for which we will utilize our continuing education trainings and governmental newsletters. Additionally, we regularly assist our clients with understanding and implementing these new standards. The standards which will be implemented in the near future:

Statement No. 100, *Accounting Changes and Error Corrections*

Statement No. 101, *Compensated Absences*

Statement No. 102, *Certain Risk Disclosures*

As noted by the numerous pronouncements issued by GASB over the past decade, the GASB continues to research various projects of interest to governmental units. Subjects of note include:

Revenue and Expense Recognition

Going Concern Uncertainty and Severe Financial Stress

Classification and Disclosure of Capital Assets

Free Continuing Education for Governmental Clients

We provide free quarterly continuing education for all of our governmental clients. Each quarter, we pick a couple of significant topics tailored to be of interest to governmental entities, and offer the sessions several times per quarter virtually and at a variety of client provided locations resulting in greater networking among our governmental clients. We normally see approximately 100-200 people per quarter. We obtain the input and services of experienced outside speakers along with our in-house professionals.

“I’ve been a CPA for 32 years. Today’s CPE class by Mauldin & Jenkins has been the best of my career”. Terry Nall, CPA, City of Dunwoody (GA) Council Member

“They are always on top of new accounting pronouncements and provide training well before implementation deadlines. This is a very valuable resource for our organization”. Laurie Puckett, CPA, CPFO, Gwinnett County (GA), Accounting Director



Examples of subjects addressed in past quarters include:

- Accounting for Debt Issuances
- Achieving Excellence in Financial Reporting
- Best Budgeting Practices, Policies and Processes
- Best Practices in Banking
- Budget Preparation
- ACFR Preparation (several times including a two (2) day hands-on course)
- Capital Asset Accounting Processes and Controls
- Closing Out and Audit Preparation
- Collateralization of Deposits and Investments
- Component Units
- Cybersecurity Risk Management
- Evaluating Financial and Non-Financial Health of a Local Government
- Financial Report Card – Where Does Your Government Stand?
- Financial Reporting Model Improvements
- GASB No. 74 & 75, New OPEB Standards
- GASB No. 77, Tax Abatement Disclosures
- GASB No. 84, Fiduciary Activities
- GASB No. 87, Leases
- GASB Projects & Updates (ongoing and several sessions)
- Grants (Accounting and Auditing)
- Human Capital Management
- Information Technology (IT) Risk Management
- Internal Controls Over Accounts Payable, Payroll and Cash Disbursements
- Internal Controls Over Receivables & the Revenue Cycle



- Internal Revenue Service (IRS) Compliance Issues, Primarily Payroll Matters
- Legal Considerations for Debt Issuances & Disclosure Requirements
- Policies and Procedures Manuals
- Presenting Financial Information to Non-Financial People
- Procurement Card Red Flags
- Risk, Efficiency, & Effectiveness in Governments
 - Segregation of Duties
 - Single Audits for Auditees
 - SPLOST Accounting, Reporting & Compliance
 - Uniform Grant Guidance



Governmental Newsletters

We produce quarterly newsletters tailored to meet the needs of governments. We also provide additional timely newsletters and announcements as necessary on any emerging topics to ensure governments stay informed of current developments in the government finance environment. The newsletters are authored by Mauldin & Jenkins governmental industry specialists and have addressed a variety of subjects. In the past several years, the following topics have been addressed in our newsletters:

- Are Your Government's Funds Secure?
- COVID-19 Updates (several)
- Cybersecurity Awareness
- Deposit Collateralization
- Employee vs Independent Contractor
- Escheat Laws on Unclaimed Property
- Federal Funding and Accountability Transparency Act
- Forensic Audit or Financial Audit?
- Form PT 440
- GASB Invitation to Comment – the New Financial Reporting Model
- GASB No. 72, Fair Value, It is Not Totally About Disclosure
- GASB No.'s 74 & 75, Other Post-Employment Benefits (OPEB)
- GASB No. 77, Abatements – Go Viral with GASB 77
- GASB No. 84 Fiduciary Activities (Series)
- GASB No. 87, Leases
- GASB No. 89, Accounting for Interest Cost Incurred Before the End of Construction
- GASB No. 91, Conduit Debt Obligations
- GASB No. 93, Replacement of Interbank Offered Rates
- General Data Protection Regulation (GDPR)

You are the best auditors I have ever worked with over my career. It is a big difference having a group that is dedicated to governmental accounting.

**Wesley Ropp,
Charleston Water System,
Chief Financial Officer**

- Grants Management
- OMB Compliance Supplements
- OPEB, What You Need to Know
- Public Funds and Secure Deposit Program
- Rotating or Not Rotating Auditors
- Property Tax Assessments
- Remote Auditing Best Practices
- Refunding Debt
- Sales & Use Taxes on Retail Sales of Jet Fuel
- Sales Tax Collections and Remittances by the State
- SAS Clarity Standards and Group Audits
- Single Audit, including Uniform Guidance (several)
- Social Security Administration (SSA) Incentive Payments
- Special Purpose Local Option Sales Taxes (SPLOST) Expenditures
- Subrecipient Risk Assessment Tool
- Supplemental Social Security for Inmates
- The New Tax Cuts and Jobs Act – Impact on Bond Refunding
- The Return of the Component Unit – GASB 61
- Uniform Guidance & New Procurement Requirements
- What’s Happening with Property Tax Assessments



Auditor’s Discussion & Analysis

During the course of serving our clients, we stress the importance of timely and frequent communication.

Such communication takes place throughout the audit and throughout the year, and includes proactive communications regarding new and upcoming accounting standards and auditing standards, as well as, the availability to answer questions and provide advice to the government.

We believe such communication is a key to providing timely value-added service to our clients.

At the conclusion of the audit process, Mauldin & Jenkins prepares an Auditor’s Discussion & Analysis (formerly called the Audit Agenda) which provides auditor insight and summarizes the audit process, conclusions, and year-end financial analysis all under one cover.

Elements of the Auditor’s Discussion & Analysis include the following:

- Information about the Firm, and the respective personnel serving the government;
- Results of the audit and other matters which should be emphasized to the governing board;

- An overview of the governments year-end financial results and auditor insights relative to key financial elements of the government;
- An understanding of the internal control/compliance audit reports and the results of our testing of internal controls and compliance with laws and regulations;
- A summary of certain audit scopes and procedures utilized by Mauldin & Jenkins during the audit process;
- Documentation of certain required communications as required by auditing standards;
- If applicable, a summary of any findings (material weaknesses and/or significant deficiencies) and management recommendations resulting from the audit;
- Practical information regarding upcoming new financial reporting and auditing standards and pronouncements affecting the government;
- A summary of the free continuing education and newsletters made available to the government during the past year.



Mauldin & Jenkins Partner Joel Black
Appointed GASB Chairman

In 2020, the Financial Accounting Foundation’s board of trustees appointed Joel Black, partner-in-charge of Mauldin & Jenkins audit practice, the next Chairman of the Governmental Accounting Standards Board.

“I am very excited to take on this new professional challenge. I have been immersed my entire adult life in the important, complex world of governmental accounting. I am eager to join my new colleagues in the mission to establish and improve accounting standards, and to engage with the remarkably diverse groups of stakeholders who

care so much about public sector financial reporting.”

“Joel Black has a longstanding and demonstrated commitment to the mission and work of the GASB and will make an excellent chair,” said Financial Accounting Foundation Chairman Kathy Casey in a statement. “He brings extensive knowledge and experience to the role and has genuine appreciation for the opportunities and challenges that our stakeholders face as accounting standards change. We are pleased to welcome him to the organization and look forward to his future leadership.”



Fee Schedule

City management has requested we provide a proposed schedule of estimated fees relative to the overall audit process of the City for the fiscal year ended June 30, 2026.

2026 \$ 50,000

In the event that the City has over \$750,000 in federal expenditures and a Single Audit is required, we propose an additional fee of \$6,000 per major program required to be audited under the Uniform Guidance.

As a member at Mauldin & Jenkins, LLC, I am certified and authorized to represent Mauldin & Jenkins, LLC, empowered to submit the bid, and authorized to sign a contract with the City.

The City of Georgetown would be a very important client to Mauldin & Jenkins and one that we are proud to serve. We will provide the City a team with significant experience working with governmental entities and local governments, as well as experience in working with the City. Thank you for allowing us to present our proposal. Please contact me at (800) 277-0050 if you have any questions or thoughts.

Very truly yours,
Mauldin & Jenkins, LLC

David Irwin, CPA
Member

800-277-0050

www.mjcpa.com

MAULDIN & JENKINS





120 North Fraser Street • Georgetown, SC 29440 • (843) 545-4000

ACTION ITEM

Council Meeting Date:	March 19, 2026
Department:	Electric Utilities
Issue Under Consideration:	Motion to approve upgrades to Front St underground infrastructure phase 4 project and award Sumter Utilities in the amount of \$631,489.00.
Amount Requested:	\$631,489.00
In Current Budget?:	Yes
If not, please explain:	
Financial Impact:	Funds are currently budgeted for FY 2026
Points to Consider:	The RFB was posted on the City of Georgetown's Solicitations website, and Sumter Utilities was the lowest qualified bidder. After reviewing their proposal, it has been determined that Sumter Utilities meets all qualifications and has a strong record of completing similar projects within the city successfully and within budget. This project will help improve the safety and reliability of the underground distribution system on Front St.
Options:	Approve or Disapprove
Staff Recommendation:	City Council Approval

Reviews:

Ryan Courtemanche
 Ryan Courtemanche
 Scott Whittier
 Stephanie Buccione

Created/Initiated
 Approved
 Approved
 Final Approval

Approver
 Approver
 Approver
 Approver

Attachments:

1. Certified Bid Tabulation Front St Phase 4
2. SIGN IN SHEET AND SUBMITTAL LISTING
3. Sumter Utilities Inc - RFB City of Georgetown Front Street Phase 4

Certified Bid Tabulation

City of Georgetown, SC
 Front St Underground Infrastructure Upgrade T2 Project – Phase 4
 COGSC Project #1932, UTEC Project #240605
 Bid Date: March 11, 2026

Item No.	Description	Qty	Unit	Unit Price (\$)	Cost (\$)	Bidder #1		Bidder #2	
						Sumter Utilities Sumter, SC	Greenwall Const. Georgetown, SC	Unit Price (\$)	Cost (\$)
1	Mobilization	1	LS	\$27,063.00	\$27,063.00	\$129,766.35	\$129,766.35		
2	Install T2 Transformers, Foundation, Cabinet	1	LS	\$97,909.00	\$97,909.00	\$46,621.05	\$46,621.05		
3	Modifications to Existing Duct Bank	1	LS	\$49,282.00	\$49,282.00	\$224,017.50	\$224,017.50		
4	Refurbish Manhole MHT2, and Pull Boxes PB4, PB5, PB6, PB7, and PB8	1	LS	\$121,782.00	\$121,782.00	\$11,550.00	\$11,550.00		
5	Primary Cables and Connections	1	LS	\$57,440.00	\$57,440.00	\$116,101.65	\$116,101.65		
6	Secondary Cables and Connections	1	LS	\$153,107.00	\$153,107.00	\$173,932.50	\$173,932.50		
7	Installation of Conduits and new Conduit Exits in Manhole MHT2	1	LS	\$30,732.00	\$30,732.00	\$14,663.88	\$14,663.88		
8	Grounding	1	LS	\$20,974.00	\$20,974.00	\$2,047.50	\$2,047.50		
9	Demolition and Removal of Existing T2 Transclosure and Pad	1	LS	\$32,489.00	\$32,489.00	\$7,602.00	\$7,602.00		
10	Safety and Traffic Control	1	LS	\$35,298.00	\$35,298.00	\$50,883.00	\$50,883.00		
11	Electrical Testing	1	LS	\$5,413.00	\$5,413.00	\$7,938.00	\$7,938.00		
Base Bid, Total of Items 1 – 11:					\$631,489.00			\$785,123.43	

I hereby certify to the best of my knowledge, the above is a true tabulation of bids received March 11, 2026.

 Kelly B. Kurz, PE

SC Professional Engineering License No. 25958



CITY OF GEORGETOWN



SUBMITTAL LISTING

PROJECT:	Front Street Phase 4 UG Infrastructure Upgrade T2 Project 1932 Request for Bid	DATE OF BID OPENING:	Wednesday, March 11, 2026, 3:00 pm
		PLACE:	Online submittals received through www.georgetownsc.gov

****NOT CERTIFIED****

SIGNED: *Nereo Parrero*

COMPANY NAME	BID AMOUNT	SUBMITTAL PACKAGE	COMMENTS:
Greenwall Construction Service Inc	\$785,123.43	All items received	Bid received on time - Currently under review
Sumter Utilities Inc	\$671,489.00	All items received	Bid received on time - Currently under review



CITY OF GEORGETOWN



SIGN IN SHEET

PROJECT:	Front Street Phase 4 UG Infrastructure Upgrade (T2) Project 1932 Request for Bid	DUE DATE:	Wednesday, March 11, 2026, 3:00 pm
FACILITATOR:	Nereo Parreno, Purchasing Agent	PLACE:	Online submittals received through www.georgetownsc.gov

Bid Opening

COMPANY NAME & ADDRESS	COMPANY REPRESENTATIVE NAME & TITLE	EMAIL ADDRESS & PHONE NUMBER	SIGNATURE/ COMMENTS:
City of Georgetown	Nereo Parreno	nparreno@georgetownsc.gov	<i>Nereo Parreno</i>
City of Georgetown	Melissa Trappier	mtrappier@georgetownsc.gov	<i>Melissa Trappier</i>
City of Georgetown	Daniella Howard	dhoward@georgetownsc.gov	<i>Daniella Howard</i>

**FRONT ST PHASE 4 UG INFRASTRUCTURE UPGRADE (T2)
CITY OF GEORGETOWN**

PROJECT MANUAL

FOR

**FRONT ST PHASE 4 UG INFRASTRUCTURE
UPGRADE (T2)**

PROJECT # 1932

CITY OF GEORGETOWN

SOUTH CAROLINA

DATE OF ISSUE: FEBRUARY 17, 2026

REV	DATE	DESCRIPTION	BY	CHK	APR

**CITY OF GEORGETOWN
ELECTRIC UTILITIES DEPARTMENT
2520 HIGHMARKET STREET
GEORGETOWN SC 29440
(843) 545-4600**

COVER PAGE

**FRONT ST PHASE 4 UG INFRASTRUCTURE UPGRADE (T2)
CITY OF GEORGETOWN**

**SECTION 00005
TABLE OF CONTENTS**

DIVISION 00 - BIDDING INSTRUCTIONS AND CONTRACT REQUIREMENTS

00001	Cover Page
00005	Table of Contents
00010	Enumeration of the Documents
00015	References
00020	Advertisement for Bids
00100	Information for Bidders
00110	Insurance Requirements
00311	Bid Form
00350	Bid Bond
00500	Contract
00600.1	Performance Bond
00601.1	Payment Bond
00601.2	Notice of Intent to Award
00602.4	Notice of Award
00604	Employment Eligibility Verification Requirements
00606	Notice to Proceed
00610	Application for Payment
00620	Contractor's Affidavit
00630	Contract Change Order
00700	General Conditions
00800	Supplementary Conditions
00900	Drawing Index
01000	Local Vendor Preference Option – Mandatory Submittal Form

TECHNICAL SPECIFICATIONS

01001	Summary of the Work
01002	Incorporation of General Conditions and Supplementary General Conditions
01003	Operation Manuals
02110	Site Preservation
02900	Seeding Disturbed Areas
03100	Concrete Formwork
03200	Concrete Reinforcement
03300	Cast-in-Place / Ready-Mix Concrete
03400	Precast Concrete Structures
16010	Basic Electrical Requirements
16050	Basic Electrical Materials and Methods
16100	Raceways, Boxes, and Cabinets
16119	Underground Ducts & Utility Structures
16120	Wires and Cables
16124	Medium Voltage Cables
16190	Supporting Devices

**FRONT ST PHASE 4 UG INFRASTRUCTURE UPGRADE (T2)
CITY OF GEORGETOWN**

16195	Electrical Identification
16320	Pad Mounted Transformers
16452	Grounding

APPENDIX A – Bid Table

(END OF SECTION)

**FRONT ST PHASE 4 UG INFRASTRUCTURE UPGRADE (T2)
CITY OF GEORGETOWN**

**SECTION 00010
ENUMERATION OF THE DOCUMENTS**

The drawings, specifications and addenda, which form a part of this contract as set forth in Paragraph 1 of the General Conditions, Contract and Contract Documents are enumerated in Section 00005 - Table of Contents.

The order of precedence when conflicts in the documents occur is as follows:

1. Permits from other Agencies as may be required by law
2. Change Orders and/or supplemental agreements according to the latest date
3. Contract Agreement
4. Addenda
5. Bid Form or Contractor's Proposal
6. Request for Bids or Proposals
7. Bidding Instructions
8. Approved Shop Drawings
9. General and Supplemental Conditions or Requirements
10. Technical Specifications
11. Plans and Details
12. City's Standard Specifications
13. State's Standard Specifications
14. Referenced Specifications: IEEE

The figured dimensions shown on the Drawings and in the Specifications may not, in every case agree with the scale dimension. Figured dimensions take precedence over scaled dimensions and finer scaled drawings take precedence of coarser scaled drawings, i.e. one inch equals twenty feet drawings takes precedence over one inch equals fifty feet drawings.

(END OF SECTION)

TABLE OF CONTENTS
00005-3

**FRONT ST PHASE 4 UG INFRASTRUCTURE UPGRADE (T2)
CITY OF GEORGETOWN**

**SECTION 00015
REFERENCES**

The following reference shall be used hereinafter:

<p><u>Owner:</u> City of Georgetown, SC PO Box 939 Georgetown, SC 29442</p>	<p>The City of Georgetown hereinafter will be referred to as the “Owner” and/or the “City”.</p>
<p><u>City Administrator:</u> Mr. Scott Whittier PO Box 939 Georgetown, SC 29442</p>	<p>Mr. Scott Whittier hereinafter will be referred to as the “City Administrator”.</p>
<p><u>Risk Manager:</u> Mr. Charles Cribb PO Box 939 Georgetown, SC 29442</p>	<p>Ms. Mr. Charles Cribb hereinafter will be referred to as the “Risk Manager”.</p>
<p><u>Purchasing Agent:</u> Mr. Nereo Parreno 1134 North Fraser Street Georgetown, SC 29440</p>	<p>Mr. Nereo Parreno hereinafter will be referred to as the “Purchasing Agent”.</p>
<p><u>Electric Utilities Director:</u> Mr. Ryan Courtemanche Director of Electric Utilities</p>	<p>Mr. Courtemanche hereinafter will be referred to as the “Electric Utilities Director”.</p>
<p><u>Project Manager</u> Mr. Ryan Courtemanche Director of Electric Utilities</p>	<p>Mr. Courtemanche also serves as the “Project Manager”.</p>
<p><u>Engineer</u> Utility Technology Engineers-Consultants</p>	<p>Utility Technology will be referred to as the “Engineer” or “UTEC”</p>

(END OF SECTION)

**FRONT ST PHASE 4 UG INFRASTRUCTURE UPGRADE (T2)
CITY OF GEORGETOWN**

**00020
ADVERTISEMENT FOR BIDS**

The City of Georgetown, requests sealed bids from qualified contractors for the above-referenced project.

Front St Phase 4 UG Infrastructure Upgrade (T2), Project # 1932 – Request for Bid (RFB)

Bids will be opened **at 3:00 pm** (EST) on Wednesday, March 11, 2026.

Bidder must make positive efforts to use women-owned or minority-owned businesses.

Bid documents including, but not limited to forms, specifications and milestone events, may be downloaded free of charge from the City website: www.georgetownsc.gov, under “Business/Bids RFPs”. You may also send an email request to purchasing@georgetownsc.gov for a direct link.

Owner: City of Georgetown.

Any prospective bidder, offeror, contractor or subcontractor who is aggrieved in connection with the solicitation of this contract may protest to Engineer (or) Owner in accordance with Section 11-35-4210 of the SC Code of Laws, within 15 days of the date of issuance of the Notice of Intent to Award.

No bid will be considered unless the bidder is legally qualified under the provisions of the South Carolina Contractor's Licensing Law (South Carolina Code of Laws as amended on April 1, 1999, Chapter 11, Sections 40-11-10 through 40-11-428).

Contractors shall have a classification of:

GENERAL CONTRACTOR-PUBLIC ELECTRICAL UTILITY (1U/2U)

No bidder may withdraw the bid within 90 days after the actual date of the opening and thereof.

Bid documents will be modified only by written addenda. It is the responsibility of the Bidder to obtain information regarding projects directly from the City’s website, www.georgetownsc.gov, under “Business/Bids/RFPs”. Bids received after the due date and specified time will not be considered for any reason.

When the Procurement Division is closed due to force majeure, bid openings will be postponed to the same time on the next official business day.

(END OF SECTION)

ADVERTISEMENT FOR BIDS
00020-1

**FRONT ST PHASE 4 UG INFRASTRUCTURE UPGRADE (T2)
CITY OF GEORGETOWN**

**00100
INFORMATION FOR BIDDERS**

1. PROJECT SUMMARY

This project is Phase 4 of Underground Electrical Upgrades along Front St. Phase 4 consists of upgrading the power distribution system associated with existing Transclosure T2 including single phase pad mounted transformers, primary and secondary cables, service cables as necessary, new electrical conduit, modifications to existing duct bank, and refurbishment of existing pull boxes and manhole.

2. RECEIPT AND OPENING OF BIDS

The City of Georgetown (hereinafter called the “Owner”) invites bids on the form (s) attached hereto, all blanks of which must be appropriately filled in.

All procurement procedures are subject to the City’s procurement policies as outlined in **Section 2-185 of** the City’s municipal code.

The City’s Purchasing Ordinance can be found in its entirety on the [City’s website](#).

Your bid must be submitted electronically to ensure it remains sealed until the scheduled bid opening date and time.

Submittals may be rejected if deemed non-responsive. To be considered, interested parties **must** submit the following no later than the aforementioned deadline:

It is the sole responsibility of the bidder to have their Bids delivered to the City before the closing hour and date. The City assumes no responsibility **for technological failure in submitting Bids electronically**. It is the sole responsibility of the bidder to consider that their Bid was submitted on time, and that their PDF file/files are not corrupt.

Bids **MUST BE** submitted electronically through the City of Georgetown’s website, www.georgetownsc.gov, under “Business/Bids”. As always, bids received after the due date and time will not be considered for any reason.

**FRONT ST PHASE 4 UG INFRASTRUCTURE UPGRADE (T2)
CITY OF GEORGETOWN**

The City **WILL NOT** accept bids by:

Hard copy

Fax

Email

Bid openings will be streamed live via the City’s public Facebook page, <https://www.facebook.com/cityofgtown/>.

To be considered responsive, interested parties **must** comply with the following:

Submit bid electronically through the City website, www.georgetownsc.gov, under “Business/Bids”.

[Click here to submit electronically.](#)

1. Submittal package must include include **all** of the following items. The PDF file upload limit is 5. If more than one PDF file is uploaded, each PDF file should be clearly labeled as such:

1. Bid Security 5%
2. Bid Form– See Section 00311
3. Bid Bond – See Section 00350
4. Mandatory Vendor Submittal Form – See Section 01000
5. Certification of Site Visit – See Section 00100

2. Electronic bid proposal must be received electronically through the City’s website, www.georgetownsc.gov, no later than the aforementioned deadline. Bids will be publicly opened and read aloud via the City’s public Facebook page, <https://www.facebook.com/cityofgtown/>. **It is the sole responsibility of the bidder to have their bid delivered to the City before the closing hour and date. The City assumes no responsibility for technological failure in submitting Bids electronically. It is the sole responsibility of the bidder to consider that their Bid was submitted on time, and that their PDF file/files are not corrupt.**

Late bids will not be accepted nor considered. The official clock shall be that of the City’s Purchasing Agent, or designee.

The City reserves the right to accept or reject any or all bids and to waive any informalities and technicalities in the bid process. No additional fees, costs, or any other reimbursable expenses will be allowed.

**FRONT ST PHASE 4 UG INFRASTRUCTURE UPGRADE (T2)
CITY OF GEORGETOWN**

The City reserves the right to waive any technicalities or informalities and to accept or reject any and/or all submissions as deemed by its sole judgment to be in its best interest. The City also reserves the right to terminate the selection process without notice, to waive any irregularities in any submittal, and to request additional information from any of the bidders submitting a bid.

The Owner may consider informal any bid not prepared and submitted in accordance with the provisions hereof and may waive any informalities or reject any and all bids. Any bid may be withdrawn prior to the above scheduled time for the opening of bids or authorized postponement thereof. Any bid received after the time and date specified shall not be considered. Bid price shall be firm for a period of ninety (90) days

3. PREPARATION OF BID

Each bid must be submitted on the prescribed form. All blank spaces for bid prices must be filled in with ink or typewritten.

Bids that are incomplete, unbalanced, conditional or obscure, or which contain additions not called for, erasures, alterations, or irregularities of any kind, or which do not comply with the Information for Bidders, may be rejected at the option of the Owner.

The correct total amount bid for the completed work is defined as the correct sum total of the amounts bid for the individual items in the proposal. The correct amount bid for each unit price item is defined as the correct product of the quantity listed for the item by the unit price bid.

Each bid must be submitted in a sealed envelope bearing on the outside the name of the Bidder, Bidder's address, Contractor's license number, Bidder's license number, and the name of the project for which the bid is submitted. If forwarded by mail, the sealed envelope containing the bid must be enclosed in another envelope addressed as specified above.

4. SUBCONTRACTS

The bidder is specifically advised that any person, firm, or other party to whom it is proposed to award a subcontract under this contract must be acceptable to the Owner.

5. QUALIFICATION OF BIDDER AND ITS SUBCONTRACTORS

The Owner may make such investigations as is deemed necessary to determine the ability of the bidder and proposed subcontractors to perform the work, and the bidder shall furnish to the Owner all such information and data for this purpose as the Owner may request.

The Owner reserves the right to reject any bid if the evidence submitted by, or investigation of, such Bidder fails to satisfy the Owner that such bidder is properly qualified to carry out the obligations of the contract and to complete the work contemplated therein. Conditional bids will not be acceptable.

**FRONT ST PHASE 4 UG INFRASTRUCTURE UPGRADE (T2)
CITY OF GEORGETOWN**

6. BID SECURITY

Bid security shall be a legitimate bid bond provided by a surety company authorized to do business in South Carolina, or the equivalent in, certified check, cashiers' check, or money order." A digital copy of the Bid Security must be submitted along with the electronic bid. The hard copy bid bond or check must be received by the purchasing agent within three (3) working days of the solicitation deadline. Mail or hand deliver only to:

City of Georgetown
Attn. Purchasing Agent
1134 N. Fraser Street
Georgetown, SC 29440

Each bid must be accompanied by certified check of the bidder, or a bid bond prepared on the form of bid bond attached hereto, duly executed by the bidder as principal and having as surety thereon a surety company approved by the Owner, in the amount of five percent (5%) of the bid. Checks will be returned to all except the three (3) lowest bidders within three (3) days after the opening of bids, and the remaining cash or checks will be returned promptly after the Owner and the accepted bidder have executed the contract, or, if no award has been made within ninety (90) days after the date of the opening of the bids, upon demand of the bidder at any time thereafter so long as bidder has not been notified of the acceptance of its bid.

7. LIQUIDATED DAMAGES FOR FAILURE TO ENTER INTO CONTRACT

The successful bidder, upon failure or refusal to execute and deliver the contract and bonds required within ten (10) days after they have received notice of the acceptance of their bid, shall forfeit to the Owner, as liquidated damages for such failure or refusal, the security deposited with the bid.

8. TIME OF COMPLETION AND LIQUIDATED DAMAGES

Bidder must agree to commence work on or before a date to be specified in a written "Notice to Proceed" of the Owner and to fully complete the project within the number of consecutive calendar days thereafter as indicated on the Bid Form. Bidder must agree also to pay as liquidated damages the sum indicated on the Bid Form for each consecutive calendar day thereafter as hereinafter provided in General Conditions.

9. CONDITIONS OF WORK

Each bidder must inform himself fully of the conditions relating to the construction of the project and the employment of labor thereon. Failure to do so will not relieve a successful bidder of the obligation to furnish all material and labor necessary to carry out the provisions of the contract.

Insofar as possible, the Contractor in carrying out the work must employ such methods and means as will not cause any interruption of, or interference with, the work of any other contractor.

**FRONT ST PHASE 4 UG INFRASTRUCTURE UPGRADE (T2)
CITY OF GEORGETOWN**

10. ADDENDA AND INTERPRETATIONS

No interpretation of the meaning of the plans, specifications, or other pre-bid documents will be made to any bidder orally. Each request for such interpretation should be in writing and addressed to the Purchasing agent. To be given consideration, the request must be received at least five (5) days prior to the date fixed for the opening of bids.

Any and all such interpretations and any supplemental instructions will be in the form of written addenda which, if issued, will be posted in the Project listing that is located at the City of Georgetown website <http://www.georgetownsc.gov>, no later than three (3) days prior to the date fixed for the opening of bids. It shall be the bidder's responsibility to check for addenda before issuing its bid. Failure of any bidder to receive any addendum shall not relieve the bidder from any obligation under its bid as submitted. All addenda so issued shall become part of the contract documents.

11. BID, PAYMENT AND PERFORMANCE BONDS

When a construction contract is awarded in excess of One Hundred Thousand Dollars (\$100,000) a payment and performance bond shall be delivered by the successful bidder to the City and shall become binding on the parties upon execution of the contract.

Simultaneously with bidder's delivery of the executed contract, the Contractor shall furnish a surety bond or bonds as secured for the faithful performance of this contract and for the payment of all persons performing labor on the project under this contract, as specified in General Conditions included herein. The surety on such bond or bonds shall be a duly authorized surety company. An agent must be provided with a South Carolina license authorized to sign and execute the bond(s). Countersignature by an agent residing in South Carolina will not be required, but execution by an agent holding a South Carolina non-resident license is required. The Bid Bond shall be an amount equal to or at least five percent (5%) of the amount of the bid. The Performance Bond shall be in the amount of one-hundred and ten percent (110%) of the bid and the Payment Bond shall be in the amount of one-hundred percent (100%) of the bid.

12. POWER OF ATTORNEY

Attorneys-in-fact who sign bonds or contract bonds must file with each bond a certified and effectively dated copy of their power of attorney.

13. NOTICE OF SPECIAL CONDITIONS

Attention is particularly called to those parts of the contract documents and specifications which deal with the following:

- A. Inspection and testing of materials
- B. Insurance requirements
- C. Stated allowances
- D. Permits and Rights-of-way
- E. Hazardous Gas Safety (Section 01060)

**FRONT ST PHASE 4 UG INFRASTRUCTURE UPGRADE (T2)
CITY OF GEORGETOWN**

14. LAWS AND REGULATIONS

The Bidder's attention is directed to the fact that all applicable State laws, municipal ordinances, and the rules and regulations of all authorities having jurisdiction over construction of the project shall apply to the contract throughout, and they will be deemed to be included in the contract the same as though herein written out in full.

15. METHOD OF AWARD - LOWEST QUALIFIED BIDDER

If at the time this contract is to be awarded, the lowest base bid or alternate bid submitted by a responsible bidder does not exceed the amount of funds then estimated by the Owner as available to finance the contract, the contract will be awarded on the base bid or alternate bid. If such bid exceeds such amount, the Owner may reject all bids or may award the contract on the base bid combined with such deductible alternates applied in numerical order in which they are listed in the Form of Bid, as produces a net amount which is within the available funds.

The Owner will decide which the lowest qualified bidder is, and in determining such bidder, the following elements will be considered for each bidder:

- Maintains a permanent place of business.
- Has successfully completed other work with the City
- Has adequate plant equipment and personnel to perform the Work properly and expeditiously.
- Has a suitable financial status to meet obligations incident to the work.
- Has appropriate technical experience with a minimum of five (5) years of practice.

16. RIGHT TO INCREASE OR DECREASE THE AMOUNT OF WORK

The work comprises approximately the quantities shown in the bid form which will be used as a basis for comparison of Bids and not for final estimate. The Owner does not, by expression or by implication, agree that the actual amount of work shall correspond with the estimated quantities. The Owner reserves the right to increase or decrease the amount of work under the Contract of the work contemplated, at the unit prices quoted in the Bid.

17. OBLIGATION OF BIDDER

At the time of the opening of bids, each bidder will be presumed to have inspected the site and to have read and been thoroughly familiar with the plans and contract documents, including all addenda. If a site visit is required, contact the Project Manager to schedule a date and time. The failure or omission of any bidder to examine any form, instrument, or document shall in no way relieve any bidder from any obligation with respect to its bid.

18. SITE VISIT PRIOR TO BID

At the time of bid, submit "Certification Regarding Site Visit Prior to Bid". See certification form at the end of the Section.

**FRONT ST PHASE 4 UG INFRASTRUCTURE UPGRADE (T2)
CITY OF GEORGETOWN**

CERTIFICATION REGARDING SITE VISIT PRIOR TO BID

PROJECT: FRONT ST PHASE 4 UG INFRASTRUCTURE UPGRADE (T2)

CITY PROJECT NO. 1932

Ben Stegner and Rusty Owens, representing the bidding contractor, visited the project (Name of Representative) site on _____, 20__ and became fully aware of all site conditions pertaining to site access and working conditions associated with the work to be performed on this project. This site condition information has been conveyed to all necessary personnel and sub-contractors preparing the bid for work on this project.

I certify that the bid for this work includes all costs associated with the site conditions, including but not limited to access, and restoration for a complete project.

Submitted by:  _____
Signature

Derek O'Bradovich
Printed Name

President
Title

Sumter Utilities, Inc.
Company

(END OF SECTION)

**FRONT ST PHASE 4 UG INFRASTRUCTURE UPGRADE (T2)
CITY OF GEORGETOWN**

**SECTION 00110
CONTRACTOR'S AND SUBCONTRACTOR'S
INSURANCE REQUIREMENTS**

1. As required under Paragraph 29 of the General Conditions, the Contractor shall not commence work under this Contract until he has obtained all the insurance required under this paragraph and such insurance has been approved by the Owner, nor shall the Contractor allow any Subcontractor to commence work on his Subcontract until all similar insurance required of the Subcontractor has been so obtained and approved.
2. Unless otherwise specified in this Contract, the Contractor shall, at its sole expense, maintain in effect at all times, during the performance of work, insurance coverage with limits not less than those set forth below with insurers and under forms of policies satisfactory to Owner.
3. The Contractor shall deliver Certificates of Insurance to the Engineer no later than ten (10) days after award of the Contract but in any event, prior to execution of the Contract by the Owner and prior to commencing work on the site as evidence that policies providing such coverage and limits of insurance are in full force and effect.
 - A. Certificates shall provide not less than thirty (30) days advance notice will be given in writing to the Owner prior to cancellation, termination, or material alteration of said policies of insurance.
 - B. Certificates shall identify on their faces the project name "**FRONT ST PHASE 4 UG INFRASTRUCTURE UPGRADE (T2)**" and the "**PROJECT NUMBER 1932**".
4. Additional Insured: The Commercial General Liability, Auto Liability, and Excess Liability (Umbrella) insurance policies shall be endorsed to include the Owner as an additional insured.
5. The Owner is not maintaining any insurance on behalf of the Contractor covering against loss or damage to the work or to any other property of the Contractor unless otherwise specifically stated herein and as may be described by appendix hereto. In the event the Contractor maintains insurance against physical loss or damage to the Contractor's construction equipment and tools, such insurance shall include an insurer's waiver of rights of subrogation in favor of the Owner.
6. The Contractor shall indemnify the Owner and the Engineer, as stated in Part 47 of The General Conditions.

**FRONT ST PHASE 4 UG INFRASTRUCTURE UPGRADE (T2)
CITY OF GEORGETOWN**

7. Insurance Requirements:

Contractor shall provide coverage for not less than the following amounts, or greater where required by Laws and Regulations:

a. Workers' Compensation and Employer's Liability

Workers' Compensation	Statutory
Employer's Liability	
Each Accident	\$ 500,000.00
Each Employee	\$ 500,000.00
Policy Limit	\$ 500,000.00

b. Commercial General Liability

General Aggregate	\$ 2,000,000.00
Products - Completed Operations Aggregate	\$ 2,000,000.00
Personal and Advertising Injury	\$ 1,000,000.00
Bodily Injury and Property Damage—Each Occurrence	\$ 1,000,000.00

c. Automobile Liability

Combined Single Limit (Bodily Injury and Property Damage)	\$ 1,000,000.00
---	-----------------

d. Excess or Umbrella Liability

Per Occurrence	\$ 2,000,000.00
General Aggregate	\$ 2,000,000.00

(END OF SECTION)

**FRONT ST PHASE 4 UG INFRASTRUCTURE UPGRADE (T2)
CITY OF GEORGETOWN**

**SECTION 00311
BID FORM**

FRONT ST PHASE 4 UG INFRASTRUCTURE UPGRADE (T2)

Date: 03/10/2026
Project No.: 1932

BID OF Sumter Utilities, Inc., doing business as a corporation / ~~a partnership~~ / ~~an individual~~ (Strike out inapplicable terms), with its principal office in the City of Sumter, County of Sumter, State of South Carolina, (hereinafter called "Bidder").

TO: City of Georgetown, SC

Gentlemen:

The Bidder, in compliance with your invitation for bids for the **Front St Phase 4 UG Infrastructure Upgrade (T2)** having examined the plans and specifications with related documents and the site of the proposed work, and being familiar with all of the conditions surrounding the construction of the proposed project, including the availability of materials and labor, hereby proposes to furnish all labor, materials, and supplies, and to construct the project in accordance with the Contract Documents, within the time set forth therein, and at the prices stated below. These prices are to cover all expenses incurred in performing the work required under the Contract Documents, of which this proposal is a part.

The bidder hereby agrees to commence work under this contract on or before a date to be specified in written "Notice to Proceed" of the Owner and to fully complete the project within **90 consecutive calendar days** thereafter as stipulated in the specifications. Bidder further agrees to pay as liquidated damages the sum of **\$500 for each consecutive calendar day** thereafter as hereinafter provided in Paragraph 19 of the General Conditions.

The plans, specifications, and addenda are complementary of each other. What is called for by one shall be as binding as if called for by all. If a conflict between any of the above is discovered by the contractor, the problem shall be referred to the Engineer as soon as possible for resolution by the Engineer. Should a conflict occur which is not resolved before bid time and/or is necessary to comply with mandatory requirements (i.e., codes, ordinances, etc.), it shall be the contractor's responsibility to price and bid the more expensive method.

Bidder acknowledges receipt of the following addendum:

No: _____ Dated: _____

No: _____ Dated: _____

No: _____ Dated: _____

Bidder agrees to perform the work as described in the specifications and shown on the plans for the following unit or lumps sum (LS) prices:

**FRONT ST PHASE 4 UG INFRASTRUCTURE UPGRADE (T2)
CITY OF GEORGETOWN**

No.	Description	Qty.	Unit	Unit Price (\$)	Cost (\$)
1	Mobilization	1	LS		27,063.00
2	Install T2 Transformers, Foundation, Cabinet	1	LS		97,909.00
3	Modifications to Existing Duct Bank	1	LS		49,282.00
4	Refurbish Manhole MHT2, and Pull Boxes PB4, PB5, PB6, PB7, and PB8	1	LS		121,782.00
5	Primary Cables and Connections	1	LS		57,440.00
6	Secondary Cables and Connections	1	LS		153,107.00
7	Installation of Conduits and new Conduit Exits in Manhole MHT2	1	LS		30,732.00
8	Grounding	1	LS		20,974.00
9	Demolition and Removal of Existing T2 Transclosure and Pad	1	LS		32,489.00
10	Safety and Traffic Control	1	LS		35,298.00
11	Electrical Testing	1	LS		5,413.00
TOTAL BID AMOUNT					631,489.00

Amounts shall be shown in both words and figures. In case of discrepancy, the amount in words shall govern.

Base Bid Lump Sum of:

Six hundred thirty one thousand, four hundred eighty nine Dollars \$ (631,489.00)

The lump sum price indicated above shall include all labor, materials, equipment, overhead, profit, insurance, taxes, business license, construction permit fees, etc., to cover all expenses incurred in performing the work required under the Contract Documents, of which this proposal is a part of.

The Bidder declares that he/she understands that the quantities shown in the Proposal are subject to adjustment by either increase or decrease and that should the quantities of any of the items of the work be increased, the undersigned proposed to do the additional work at the unit prices stated herein, and should the quantities be decreased, he also understands that payment will be made on actual quantities at the unit price bid, and will make no claim for anticipated profits for any decrease in the quantities and that actual quantities will be determined upon completion of the work, at which time adjustment will be made to the contract amount by direct increase or decrease.

Bidder understands that the Owner reserves the right to reject any or all bids and to waive any informalities in the bidding.

The Bidder agrees that this bid shall be good and may not be withdrawn for a period of 90 calendar days after the scheduled closing time for receiving bids.

Upon receipt of written notice of the acceptance of this bid, Bidder will execute the formal contract attached within 10 days and deliver a Surety Bond or Bonds as required by Paragraph 30 of the General Conditions. The bid security attached in the sum of Six hundred thirty one thousand, four hundred eighty nine Dollars zero Cents (\$ 631,489.00) is to become the property of the Owner in the event the contract and bond

**FRONT ST PHASE 4 UG INFRASTRUCTURE UPGRADE (T2)
CITY OF GEORGETOWN**

are not executed within the time above set forth, as liquidated damages for the delay and additional expense to the Owner caused thereby.

By submission of this bid, each bidder certifies, and in the case of a joint bid, each party thereto certifies as to its own organization, that this bid has been arrived at independently, without consultation, communication, or agreement as to any matter relating to this bid, with any other bidder or with any competitor.

[SEAL – (If bid is by a corporation)]

Respectfully submitted:

BY:



Derek O'Bradovich
(Print Name)

President
(Title)

1151 N Pike W Sumter, SC 29153
(Business Address)

bstegner@suimail.com
(Email)

803-469-8585
(Telephone)

**FRONT ST PHASE 4 UG INFRASTRUCTURE UPGRADE (T2)
CITY OF GEORGETOWN**

**SECTION 00350
BID BOND**

KNOW ALL MEN BY THESE PRESENT:

That we, the undersigned Sumter Utilities, Inc., as Principal, and City of Georgetown, as Surety, are hereby held and firmly bound unto the City of Georgetown, South Carolina, as Owner, in the penal sum of (5% of total bid) Five Percent of Amount Bid Dollars 00 Cents (\$ 5% of Amount Bid), for the payment of which, well and truly to be made, we hereby jointly and severally bind ourselves, successors and assigns.

Signed this 27th day of February, 2026.

The condition of the above obligation is such that:

WHEREAS, the Principal has submitted to City of Georgetown a certain Bid, attached hereby and by reference made a part hereof, to enter into a contract in writing for the **FRONT ST PHASE 4 UG INFRASTRUCTURE UPGRADE (T2)**.

NOW, THEREFORE,

- (A) If said Bid shall be rejected, or
- (B) If said Bid shall be accepted and the Principal shall execute and deliver a contract in the Form of Contract attached hereto (properly completed in accordance with said Bid) and shall furnish a Bond for faithful performance of said contract, and for the payment of all persons performing labor furnishing materials in connection therewith, and shall in all other respects perform the agreement created by the acceptance of said Bid, then this obligation shall be void; otherwise the same shall remain in force and effect - it being expressly understood and agreed that the liability of the Surety for any and all claims hereunder shall, in no event, exceed the penal amount of this obligation as herein stated.

The Surety, for value received, hereby stipulates and agrees that the obligations of said Surety and its Bond shall be in no way impaired or affected by an extension of the time within which the Owner may accept such Bid, and said Surety does hereby waive notice of any such extension.

IN WITNESS WHEREOF, the Principal and Surety have hereunto set their hands and seals, and such of them as are corporations have caused their corporate seals to be hereto affixed and these presents to be signed by their proper officers, the day and year first set forth above.

BID BOND
00350-1

FRONT ST PHASE 4 UG INFRASTRUCTURE UPGRADE (T2)
CITY OF GEORGETOWN

Principal Sumter Utilities, Inc.

(Corporate Seal)

By :  (L.S)

Derek O'Bradovich, President

Federal Insurance Company

Surety

By :  (L.S)

Loudan Braun, Attorney-In-Fact



Important:

Surety companies executing Bonds must appear on the Treasury Department's most current list (Circular 570 as amended) and be authorized to transact business in the state where the project is located.

(END OF SECTION)

BID BOND
00350-2



Power of Attorney

Federal Insurance Company | Vigilant Insurance Company | Pacific Indemnity Company
Westchester Fire Insurance Company | ACE American Insurance Company

Know All by These Presents, that FEDERAL INSURANCE COMPANY, an Indiana corporation, VIGILANT INSURANCE COMPANY, a New York corporation, PACIFIC INDEMNITY COMPANY, a Delaware corporation, WESTCHESTER FIRE INSURANCE COMPANY and ACE AMERICAN INSURANCE COMPANY corporations of the Commonwealth of Pennsylvania, do each hereby constitute and appoint Mark V. Baechle, Kimberly Bragg, Loudan Braun, Sarah E. Green, Susan K. Landreth and Rebecca Sanford of Chicago, Illinois; Paula M. Eby of Columbus, Ohio

each as their true and lawful Attorney-in-Fact to execute under such designation in their names and to affix their corporate seals to and deliver for and on their behalf as surety thereon or otherwise, bonds and undertakings and other writings obligatory in the nature thereof (other than bail bonds) given or executed in the course of business, and any instruments amending or altering the same, and consents to the modification or alteration of any instrument referred to in said bonds or obligations.

In Witness Whereof, said FEDERAL INSURANCE COMPANY, VIGILANT INSURANCE COMPANY, PACIFIC INDEMNITY COMPANY, WESTCHESTER FIRE INSURANCE COMPANY and ACE AMERICAN INSURANCE COMPANY have each executed and attested these presents and affixed their corporate seals on this 6th day of June, 2025.

[Signature of Rupert HD Swindells]
Rupert HD Swindells, Assistant Secretary

[Signature of Stephen M. Haney]
Stephen M. Haney, Vice President



STATE OF NEW JERSEY
County of Hunterdon SS.

On this 6th day of June, 2025 before me, a Notary Public of New Jersey, personally came Rupert HD Swindells and Stephen M. Haney, to me known to be Assistant Secretary and Vice President, respectively, of FEDERAL INSURANCE COMPANY, VIGILANT INSURANCE COMPANY, PACIFIC INDEMNITY COMPANY, WESTCHESTER FIRE INSURANCE COMPANY and ACE AMERICAN INSURANCE COMPANY, the companies which executed the foregoing Power of Attorney, and the said Rupert HD Swindells and Stephen M. Haney, being by me duly sworn, severally and each for himself did depose and say that they are Assistant Secretary and Vice President, respectively, of FEDERAL INSURANCE COMPANY, VIGILANT INSURANCE COMPANY, PACIFIC INDEMNITY COMPANY, WESTCHESTER FIRE INSURANCE COMPANY and ACE AMERICAN INSURANCE COMPANY and know the corporate seals thereof, that the seals affixed to the foregoing Power of Attorney are such corporate seals and were thereto affixed by authority of said Companies; and that their signatures as such officers were duly affixed and subscribed by like authority.

Notarial Seal



Albert Contursi
NOTARY PUBLIC OF NEW JERSEY
No 50202369
Commission Expires August 22, 2027

[Signature of Albert Contursi]
Notary Public

CERTIFICATION

Resolutions adopted by the Boards of Directors of FEDERAL INSURANCE COMPANY, VIGILANT INSURANCE COMPANY, and PACIFIC INDEMNITY COMPANY on August 30, 2016; WESTCHESTER FIRE INSURANCE COMPANY on December 11, 2006; and ACE AMERICAN INSURANCE COMPANY on March 20, 2009:

"RESOLVED, that the following authorizations relate to the execution, for and on behalf of the Company, of bonds, undertakings, recognizances, contracts and other written commitments of the Company entered into in the ordinary course of business (each a "Written Commitment"):

- (1) Each of the Chairman, the President and the Vice Presidents of the Company is hereby authorized to execute any Written Commitment for and on behalf of the Company, under the seal of the Company or otherwise.
(2) Each duly appointed attorney-in-fact of the Company is hereby authorized to execute any Written Commitment for and on behalf of the Company, under the seal of the Company or otherwise, to the extent that such action is authorized by the grant of powers provided for in such person's written appointment as such attorney-in-fact.
(3) Each of the Chairman, the President and the Vice Presidents of the Company is hereby authorized, for and on behalf of the Company, to appoint in writing any person the attorney-in-fact of the Company with full power and authority to execute, for and on behalf of the Company, under the seal of the Company or otherwise, such Written Commitments of the Company as may be specified in such written appointment, which specification may be by general type or class of Written Commitments or by specification of one or more particular Written Commitments.
(4) Each of the Chairman, the President and the Vice Presidents of the Company is hereby authorized, for and on behalf of the Company, to delegate in writing to any other officer of the Company the authority to execute, for and on behalf of the Company, under the Company's seal or otherwise, such Written Commitments of the Company as are specified in such written delegation, which specification may be by general type or class of Written Commitments or by specification of one or more particular Written Commitments.
(5) The signature of any officer or other person executing any Written Commitment or appointment or delegation pursuant to this Resolution, and the seal of the Company, may be affixed by facsimile on such Written Commitment or written appointment or delegation.

FURTHER RESOLVED, that the foregoing Resolution shall not be deemed to be an exclusive statement of the powers and authority of officers, employees and other persons to act for and on behalf of the Company, and such Resolution shall not limit or otherwise affect the exercise of any such power or authority otherwise validly granted or vested."

I, Rupert HD Swindells, Assistant Secretary of FEDERAL INSURANCE COMPANY, VIGILANT INSURANCE COMPANY, PACIFIC INDEMNITY COMPANY, WESTCHESTER FIRE INSURANCE COMPANY and ACE AMERICAN INSURANCE COMPANY (the "Companies") do hereby certify that

- (i) the foregoing Resolutions adopted by the Board of Directors of the Companies are true, correct and in full force and effect,
(ii) the foregoing Power of Attorney is true, correct and in full force and effect.

Given under my hand and seals of said Companies at Whitehouse Station, NJ, this February 27th, 2026



[Signature of Rupert HD Swindells]
Rupert HD Swindells, Assistant Secretary

IN THE EVENT YOU WISH TO VERIFY THE AUTHENTICITY OF THIS BOND OR NOTIFY US OF ANY OTHER MATTER, PLEASE CONTACT US AT:
Telephone (908) 903-3493 Fax (908) 903-3656 e-mail: surety@chubb.com

**FRONT ST PHASE 4 UG INFRASTRUCTURE UPGRADE (T2)
CITY OF GEORGETOWN**

**SECTION 00500
CONTRACT**

STATE OF SOUTH CAROLINA

COUNTY OF GEORGETOWN

THIS AGREEMENT, entered into this ____ day of _____, 20____ and effective immediately by and between _____, doing business as a (individual/partnership/corporation), with its principal office in the City of _____, _____ County, _____ State,(hereinafter called the "Contractor") and the City of Georgetown, a duly organized and validly existing politic body of the State of South Carolina (hereinafter called "City"),

WITNESSETH THAT WHEREAS, The City desires to engage the services of a professional contractor for the purpose of **Front St Phase 4 UG Infrastructure Upgrade (T2)**, hereinafter referred to as "Project"; and,

WHEREAS, The City has solicited bids for same by that certain Request for Bids for Construction Services, hereinafter referred to as "RFB", a copy of which is attached hereto for all purposes as **EXHIBIT "1"**; and,

WHEREAS, The Contractor has represented to City that it has the qualifications, experience, expertise, training, and personnel to timely perform the Project for City; and,

WHEREAS, The Contractor has expressed its desire to do so by their bid opened _____, 20____, hereinafter referred to as "Bid", a copy of which is attached hereto for all purposes as **EXHIBIT "2"**;and,

WHEREAS, the parties desire to enter in an agreement for the Contractor to perform the Project for City per all the terms and conditions more particularly set out herein below;

NOW, THEREFORE, for and in consideration of the foregoing, and of other good and valuable consideration, the adequacy of which is hereby acknowledged, the parties hereto agree as follows:

**CONTRACT
00500-1**

**FRONT ST PHASE 4 UG INFRASTRUCTURE UPGRADE (T2)
CITY OF GEORGETOWN**

(1) **SCOPE OF SERVICES:**

- a. Contractor hereby agrees to perform a project for the **Front St Phase 4 UG Infrastructure Upgrade (T2)** as outlined in the Project Manual, incorporated into this Agreement as **ATTACHMENT "A"** and hereinafter referred to as "Work";
- b. Contractor further agrees to commence and complete any and all extra work in connection therewith, under the terms as stated in the General and Special Conditions of the Contract; and at his/hers (it's or their) own proper cost and expense to furnish all the materials, supplies, machinery, equipment, tools, superintendents, labor, insurance, and other accessories and services necessary to complete the said project in accordance with the conditions and prices stated in the Proposal and the General Conditions, Supplemental General Conditions, and Special Provisions of the Contract, the plans, including all maps, plats, blueprints, and other drawings and printed or written explanatory matters thereof, the specifications and contract documents therefore as prepared by the Engineer, and as enumerated in Paragraph 1 of the General Conditions, all of which are made a part hereof and collectively evidence and constitute the Contract.
- c. City may, from time to time require changes in the Work of the Contractor to be performed hereunder. Such changes, which are mutually agreed upon by and between City and the Contractor, shall be incorporated by written amendment to this Agreement.

(2) **COMPENSATION:**

- a. City agrees to pay Contractor a sum not to exceed _____ dollars (\$_____.__) in accordance with the Schedule of Values, incorporated into this Agreement as **ATTACHMENT "B"** and hereinafter referred to as "Compensation";
- b. In the event funds are not appropriated or become non-appropriated for an included fiscal year by City, it is agreed by the parties that this Agreement will become null and void and the City's obligations cannot extend beyond the date of non-appropriation.

**FRONT ST PHASE 4 UG INFRASTRUCTURE UPGRADE (T2)
CITY OF GEORGETOWN**

(3) **PERIOD OF SERVICES:**

- a. The Work to be performed hereunder by the Contractor shall begin upon the date outlined to the City's Notice to Proceed letter to the Contractor, incorporated into this Agreement as ATTACHMENT "C" and hereinafter referred to as "NTP"
- b. The Work shall be completed in accordance with the Schedule, incorporated into this Agreement as ATTACHMENT "D" and hereinafter referred to as "Schedule".
- c. Modifications to the Schedule may be required. Such modifications, which are mutually agreed upon by and between City and the Contractor shall be incorporated by written amendment to this Agreement.

(4) **FORCE MAJEURE:**

- a. Force majeure includes acts of God, acts of other branches of government in either their sovereign or contractual capacities, or any similar cause beyond the reasonable control of the parties.
- b. Any delays in or failure of performance by either party that are caused by a Force Majeure shall not constitute breach of this Agreement.
- c. In the event that any event of force majeure, as herein defined occurs, both parties shall be entitled to a reasonable extension of time for performance of its WORK.

(5) **NOTICES:**

- a. Any notices, bills, invoices, or reports required by this Agreement shall be sufficient if sent by the parties in the United States mail or electronic mail to the addresses of the Project Manager (See Section 00015)

(6) **RECORDS AND INSPECTIONS:**

- a. Contractor shall maintain full and accurate records with respect to all matters covered under this Agreement for a period of one year after the completion of the project.
- b. City shall have free access at all proper times to such records, and the right to examine and audit the same and to make transcripts there from, and to inspect all program data, documents, proceedings, and activities.

**FRONT ST PHASE 4 UG INFRASTRUCTURE UPGRADE (T2)
CITY OF GEORGETOWN**

(7) COMPLETENESS OF AGREEMENT:

- a. This Agreement and any additional or supplementary document or documents incorporated herein by specific reference contain all the terms and conditions agreed upon by the parties hereto, and no other agreements, oral or otherwise, regarding the subject matter of this Agreement or any part thereof shall have any validity or bind any of the parties hereto
- b. This Agreement is entered into with full understanding and awareness of such requirement.
- c. City shall be allowed to rely upon the representations of Contractor as set out in the Proposal.
- d. With the exception of the foregoing, this Agreement constitutes the entire agreement between the parties hereto and may not be modified or amended except in writing signed by both parties hereto.

(8) CONFLICTS:

- a. In the case of any conflict between the terms and conditions of this Agreement and the terms of any other agreement between the parties hereto, the terms of this Agreement shall control
- b. If there is a conflict between the City's Requests for Bids and this Agreement, then this Agreement shall control.
- c. If there is a conflict between the City's Request for Bids and the Contractor's Proposal, the City's Request for Bids shall control.
- d. Both parties agree that all conflicts arising under this Agreement that cannot be settled between the parties shall be resolved in the Georgetown County Court of Common Pleas (Non-Jury)

(9) SEVERABILITY:

- a. If any part or provision of this Agreement is held invalid or unenforceable under applicable law, such invalidity or unenforceability shall not in any way affect the validity or enforceability of the remaining parts and provisions of this Agreement.

**FRONT ST PHASE 4 UG INFRASTRUCTURE UPGRADE (T2)
CITY OF GEORGETOWN**

(10) **NONWAIVER:**

- a. The waiver by City or Contractor of a breach of this Agreement shall not operate as a waiver of any subsequent breach, and no delay in acting with regard to any breach of this Agreement shall be construed to be a waiver of the breach.
- b. In no event shall the making of any payment by City to the Contractor constitute or be construed as a waiver by City of any breach of covenant, or any default which may exist on the part of the Contractor.
- c. The making of any such payment by City while any such breach or default shall exist in no way impairs or prejudices any right or remedy available to City in respect to such breach or default.

(11) **GOVERNING LAW:**

- a. This Agreement and the rights, obligations and remedies of the parties hereto, shall in all respects be governed by and construed in accordance with the laws of the State of South Carolina.

(12) **RESPONSIBILITY:**

- a. Each party shall be responsible for its own acts as provided under the law of South Carolina and will be responsible for all damages, costs, fees and expenses which arise out of the performance of this Agreement which are due to that party's own negligence, tortious acts and other unlawful conduct and the negligence, tortious action and other unlawful conduct of its respective agents, officers and employees.

(13) **FREEDOM OF INFORMATION ACT (FOIA)**

- a. The parties acknowledge that all documents are subject to release under the South Carolina Freedom of Information Act (FOIA) and will be released to the public unless exempt from disclosure under the FOIA.

**FRONT ST PHASE 4 UG INFRASTRUCTURE UPGRADE (T2)
CITY OF GEORGETOWN**

- b. If the Contractor contends a document is exempt from disclosure under the FOIA, it shall mark any such documents plainly, and seek protection from disclosure by filing an appropriate action in Circuit Court and shall bear the cost of the action and any monetary or attorney's fees awarded to the person or entity making the FOIA request.
- c. If the Contractor objects to release and litigation is commenced against the City under the FOIA, the City agrees to promptly notify the Contractor, who shall move in intervene as a party. The Contractor agrees to hold the City harmless from and indemnify for all costs (including plaintiff's attorney's fees if awarded by the Court) incurred by the City in defending the lawsuit and the funds necessary to satisfy any judgment and all costs on appeal, if any.

(14) **THIRD-PARTY OBLIGATIONS:**

- a. Neither party shall be obligated or liable hereunder to any party other than the second party to this Agreement.

(15) **RESTRICTIONS ON LOBBYING:**

- a. The Contractor shall comply with all requirements of Section 1352, Title 31 of the U.S. Code, which prohibits all recipients of federal funds from using appropriated monies for lobbying activities.

(16) **SUCCESSORS AND ASSIGNS:**

- a. The rights and obligations herein shall inure to and be binding upon the successors and assigns of the parties hereto.

**FRONT ST PHASE 4 UG INFRASTRUCTURE UPGRADE (T2)
CITY OF GEORGETOWN**

IN WITNESS WHEREOF, City and the Contractor have executed this agreement as of the date first written above.

CITY OF GEORGETOWN, SOUTH CAROLINA
(OWNER)

(SIGNATURE)

By: _____

(SEAL)

Title: _____

(CONTRACTOR)

(SIGNATURE)

By: _____

(CORPORATE SEAL)

Title: _____

Attest:

It's Secretary

Witness

(END OF SECTION)

CONTRACT
00500-7

**FRONT ST PHASE 4 UG INFRASTRUCTURE UPGRADE (T2)
CITY OF GEORGETOWN**

**SECTION 00600.1
PERFORMANCE BOND**

KNOW ALL MEN BY THESE PRESENTS THAT

(NAME OF CONTRACTOR)

(ADDRESS OF CONTRACTOR)

A Corporation Partnership, hereinafter called Principal, and

(NAME OF SURETY)

(ADDRESS OF SURETY)

Hereinafter called Surety, are held and firmly bound unto

THE CITY OF GEORGETOWN, SOUTH CAROLINA
(NAME OF OWNER)

PO BOX 939, GEORGETOWN, SC 29442
(ADDRESS OF OWNER)

hereinafter called Owner, in the penal sum of (110% of total bid)
_____ Dollars _____ Cents (\$ _____),
in lawful money of the United States, for the payment of which sum well and truly to be made,
we bind ourselves, our heirs, executors, administrators, and successors, jointly and severally,
firmly by these present.

THE CONDITION OF THIS OBLIGATION is such that whereas the Principal entered into a certain Contract with the Owner dated the _____ day of _____, 20____, a copy of which is hereto attached and made part hereof for **FRONT ST PHASE 4 UG INFRASTRUCTURE UPGRADE (T2)**.

NOW, THEREFORE, if the Principal shall well, truly, and faithfully perform its duties, all the undertakings, covenants, terms, conditions, and agreements of said Contract during the original term thereof, and any extensions thereof which may be granted by the Owner, with or without notice to the Surety, and if he shall satisfy all claims and demands incurred under such contract and fully indemnify and save harmless the Owner from all costs and damages which it may suffer by reason of failure to do so, and shall reimburse and repay the Owner all outlay and expense which the Owner may incur in making good any default, then this obligation shall be void; otherwise to remain in full force and effect.

PERFORMANCE BOND
00600.1-1

**FRONT ST PHASE 4 UG INFRASTRUCTURE UPGRADE (T2)
CITY OF GEORGETOWN**

PROVIDED FURTHER, that the said Surety, for value received hereby stipulates and agrees that no change, extensions of time, alteration, or addition to the terms of the Contract or to the work to be performed thereunder or the specifications accompanying the same shall in any way affect its obligation on this bond, and it does hereby waive notice of any such change, extension of time, alteration or addition to the terms of the Contract or to the work or to the specifications.

PROVIDED FURTHER, that no final settlement between the Owner and the Contractor shall abridge the right of any beneficiary hereunder, whose claim may be unsatisfied.

IN WITNESS WHEREOF, this instrument is executed in three (3) counterparts, each one of which shall be deemed an original, this the _____ day of _____, 20____.

Signed, sealed and delivered in the presence of:

(PRINCIPAL - CONTRACTOR)

(SIGNATURE)

As to Principal

By: _____

Title: _____

(SURETY)

(SIGNATURE)

As to Surety

By: _____

ATTORNEY-IN-FACT
(Power of Attorney to be attached)

**FRONT ST PHASE 4 UG INFRASTRUCTURE UPGRADE (T2)
CITY OF GEORGETOWN**

By: _____
(AGENT)

(AGENT COMPANY NAME)

(AGENT COMPANY ADDRESS)

(AGENT ADDRESS)

NOTES:

1. Date of Bond must not be prior to date of Contract.
2. If Contractor is a Partnership, all partners should execute Bond.
3. Surety companies executing Bonds must appear on the Treasury Department's most current list (Circular 570 as amended) and be authorized to transact business in the state where the project is located.

(END OF SECTION)

PERFORMANCE BOND
00600.1-3

**FRONT ST PHASE 4 UG INFRASTRUCTURE UPGRADE (T2)
CITY OF GEORGETOWN**

**SECTION 00601.1
PAYMENT BOND**

KNOW ALL MEN BY THESE PRESENTS THAT

(NAME OF CONTRACTOR)

(ADDRESS OF CONTRACTOR)

A Corporation Partnership, hereinafter called Principal, and

(NAME OF SURETY)

(ADDRESS OF SURETY)

Hereinafter called Surety, are held and firmly bound unto

THE CITY OF GEORGETOWN, SOUTH CAROLINA
(NAME OF OWNER)

PO BOX 939, GEORGETOWN, SC 29442
(ADDRESS OF OWNER)

hereinafter called Owner, in the penal sum of (100% of total bid)
_____ Dollars _____ Cents (\$ _____),
in lawful money of the United States, for the payment of which sum well and truly to be made,
we bind ourselves, our heirs, executors, administrators, and successors, jointly and severally,
firmly by these present.

THE CONDITION OF THIS OBLIGATION is such that whereas the Principal entered into a
certain Contract with the Owner dated the _____ day of _____, 20____, a
copy of which is hereto attached and made part hereof for **FRONT ST PHASE 4 UG
INFRASTRUCTURE UPGRADE (T2)**.

NOW, THEREFORE, if the Principal shall promptly make payment to all persons, firms,
subcontractors, and corporations furnishing materials for or performing labor in the prosecution of
the work provided for in such contract, and any authorized extension of modification thereof,
including all amounts due for materials, lubricants, oil, gasoline, coal and coke, repairs on
machinery, equipment and tools, consumed or used in connection with the construction of such
work, and all insurance premiums on said work, and for all labor, performed in such work whether
by subcontractor or otherwise, then this obligation shall be void; otherwise to remain in full force
and effect.

PAYMENT BOND
00601.1-1

**FRONT ST PHASE 4 UG INFRASTRUCTURE UPGRADE (T2)
CITY OF GEORGETOWN**

PROVIDED FURTHER, that the said Surety, for value received hereby stipulates and agrees that no change, extensions of time, alteration, or addition to the terms of the Contract or to the work to be performed thereunder or the specifications accompanying the same shall in any way affect its obligation on this bond, and it does hereby waive notice of any such change, extension of time, alteration or addition to the terms of the Contract or to the work or to the specifications.

PROVIDED FURTHER, that no final settlement between the Owner and the Contractor shall abridge the right of any beneficiary hereunder, whose claim may be unsatisfied.

IN WITNESS WHEREOF, this instrument is executed in three (3) counterparts, each one of which shall be deemed an original, this _____ day of _____, 20____.

Signed, sealed and delivered in the presence of:

(PRINCIPAL - CONTRACTOR)

(SIGNATURE)

As to Principal

By: _____

Title: _____

(SURETY)

(SIGNATURE)

As to Surety

By: _____

ATTORNEY-IN-FACT
(Power of Attorney to be attached)

**FRONT ST PHASE 4 UG INFRASTRUCTURE UPGRADE (T2)
CITY OF GEORGETOWN**

By: _____
(AGENT)

(AGENT COMPANY NAME)

(AGENT COMPANY ADDRESS)

(AGENT ADDRESS)

NOTES:

1. Date of Bond must not be prior to date of Contract.
2. If Contractor is a Partnership, all partners should execute Bond.
3. Surety companies executing Bonds must appear on the Treasury Department's most current list (Circular 570 as amended) and be authorized to transact business in the state where the project is located.

(END OF SECTION)

PAYMENT BOND
00601.1-3

**FRONT ST PHASE 4 UG INFRASTRUCTURE UPGRADE (T2)
CITY OF GEORGETOWN**

SECTION 00601.2

NOTICE OF INTENT TO AWARD

OWNER: City of Georgetown
2520 Highmarket St
Georgetown, SC 29440

PROJECT NO.: 1932

PROJECT DESCRIPTION: Front St Phase 4 UG Infrastrucgture Upgrade (T2)

TO ALL BIDDERS:

This is to notify all bidders that it is the intent of the Owner to award a contract as follows:

NAME OF BIDDER: _____

DATE BIDS WERE RECEIVED: _____

AMOUNT OF BASE BID: _____ \$ _____

The Owner has determined that the above-named Bidder is responsible and has submitted the lowest responsive bid. The Owner may enter into a contract with this Bidder subject to the contract review and approval by the RIA and City Council.

(Print or Type Name)

(Title)

(Signature)

(Date Posted)

(END OF SECTION)

NOTICE OF INTENT TO AWARD
00601.2

**FRONT ST PHASE 4 UG INFRASTRUCTURE UPGRADE (T2)
CITY OF GEORGETOWN**

**SECTION 00602.4
NOTICE OF AWARD**

TO: _____

PROJECT: Front St Phase 4 UG Infrastructure Upgrade (T2)

PROJECT NO. : 1932

DATE: _____

The City of Georgetown (Owner) has considered your proposal in response to the Request for Bid (RFB) dated _____.

You are hereby notified that Owner has approved your bid in the amount of \$_____.

You are required to provide the following documents: W-9 form, Employment Verification Affidavit, City's business license (or per-job business license), Payment and Performance bonds, and Certificate of Insurance naming the City of Georgetown as additionally insured, within ten (10) business days from the date of this notice to you. A Purchase Order and contract agreement will then be prepared once the requested documents are on hand.

Please sign and return this form in acknowledgment of this Notice of Award to the Owner.

CITY OF GEORGETOWN, SOUTH CAROLINA

By: _____

Title: _____

Acceptance of Notice

Receipt of the above Notice of Award is hereby acknowledged this _____ day of _____, 20____.

(Signature)

By: _____

Title: _____

(END OF SECTION)

NOTICE OF AWARD
00602.4

**FRONT ST PHASE 4 UG INFRASTRUCTURE UPGRADE (T2)
CITY OF GEORGETOWN**

**SECTION 00604
EMPLOYMENT ELIGIBILITY VERIFICATION REQUIREMENT**

- A. Contractor is required to comply with all applicable State and Federal employment eligibility verification requirements including but not limited to the following:
1. By signing its bid or proposal, Contractor certifies that it will comply with the applicable requirements of Title 41, Chapter 8 of the South Carolina Code of Laws and agrees to provide to the City of Georgetown upon request any documentation required to establish either: (a) that Title 41, Chapter 8 is inapplicable both to Contractor and its subcontractors or sub-subcontractors are in compliance with Title 41, Chapter 8. Pursuant to Section 41-8-70, "In addition to other penalties provided by law, a person who knowingly makes or files any false, fictitious, or fraudulent document, statement, or report pursuant to this chapter is guilty of a felony, and upon conviction, must be fined within the discretion of the court or imprisoned for not more than five years, or both. "Contractor agrees to include in any contracts with its subcontractors language requiring its subcontractors to (a) comply with the applicable requirement of Title 41, Chapter 8, and (b) include in their contracts with the sub-subcontractors language requiring the sub-subcontractors to comply with the applicable requirements of Title 41, Chapter 8.
- B. Contractor is required to complete and submit the attached affidavit along with the executed contract documents.
- C. E-Verify.
1. In addition to completing and maintaining the federal employment eligibility verification form (Form I-9), Contractor must, within three (3) business days after employing a new employee, verify the employee's work authorization through the E-Verify federal work authorization program administered by the U.S. Department of Homeland Security. Employers may no longer confirm a new employee's employment authorization with a driver's license or state identification card.
 2. Contractor shall enroll in E-Verify at www.dhs.gov/e-verify.

**FRONT ST PHASE 4 UG INFRASTRUCTURE UPGRADE (T2)
CITY OF GEORGETOWN**

CONTRACTOR AFFIDAVIT

SOUTH CAROLINA ILLEGAL IMMIGRATION REFORM ACT (Amended)

In accordance with the requirements of the South Carolina Illegal Immigration Reform Act, Contractor hereby certifies that it is currently in compliance with the requirements of Title 40, Chapter 8 of the S.C. Code Annotated and will remain in compliance with such requirements throughout the term of its contract with the Owner.

The Contractor hereby acknowledges that in order to comply with the requirements of S.C. Code Annotated Section 41-8-20:

- (A) All private employers in South Carolina shall be imputed a South Carolina employment license, which permits a private employer to employ a person in this State. A private employer may not employ a person unless the private employer's South Carolina employment license and any other applicable licenses as defined in Section 41-8-10 are in effect and are not suspended or revoked. A private employer's employment license shall remain in effect provided the private employer complies with the provisions of this chapter.
- (B) All private employers who are required by federal law to complete and maintain federal employment eligibility verification forms or documents must register and participate in the E-Verify federal work authorization program, or its successor, to verify the work authorization of every new employee within three business days after employing a new employee. A private employer who does not comply with the requirements of this subsection violates the private employer's licenses.
- (C) The South Carolina Department of Employment and Workforce shall provide private employers with technical advice and electronic access to the E-Verify federal work authorization program's website for the sole purpose of registering and participating in the program.
- (D) Private employers shall employ provisionally a new employee until the new employee's work authorization has been verified pursuant to this section. A private employer shall submit a new employee's name and information for verification even if the new employee's employment is terminated less than three business days after becoming employed. If a new employee's work authorization is not verified by the federal work authorization program, a private employer must not employ, continue to employ, or reemploy the new employee.
- (E) To assist private employers in understanding the requirements of this chapter, the director shall send written notice of the requirements of this section to all South Carolina employers and shall publish the information contained in the notice on its website.

**EMPLOYMENT VERIFICATION
00604-2**

**FRONT ST PHASE 4 UG INFRASTRUCTURE UPGRADE (T2)
CITY OF GEORGETOWN**

Nothing in this section shall create a legal requirement that any private employer receive actual notice of the requirements of this chapter through a written notice from the director, nor create any legal defense for failure to receive notice.

- (F) If a private employer is a contractor, the private employer shall maintain the contact phone numbers of all subcontractors and sub-subcontractors performing services for the private employer. The private employer shall provide the contact phone numbers or a contact phone number, as applicable, to the director pursuant to an audit or investigation within seventy-two hours of the director's request.

The Contractor agrees to provide to the Owner upon request any documentation required to establish the applicability of the South Carolina Illegal Immigration Reform Act (Amended) to the contractor, subcontractor or sub-subcontractor. The Contractor further agrees that it will upon request provide the Owner with any documentation required to establish that the Contractor and any subcontractors or sub-subcontractors are in compliance with the requirements of Title 41, Chapter 8 of the S.C. Code Annotated.

Date: 03/10/2026



(Signature)

By: Derek O'Bradovich

Title: President

(END OF SECTION)

**FRONT ST PHASE 4 UG INFRASTRUCTURE UPGRADE (T2)
CITY OF GEORGETOWN**

**SECTION 00606
NOTICE TO PROCEED**

TO:

OWNER: City of Georgetown, South Carolina

PROJECT: Front St Phase 4 UG Infrastructure Upgrade (T2)

PROJECT NUMBER: 1932

DATE: _____

This is your Notice to Proceed with the Work, on the above-mentioned Project, in accordance with The Agreement dated _____, 20____. You are authorized to commence Work on _____ 20____, and you are required to complete the Work within **Ninety (90)** consecutive calendar days thereafter.

The date of final completion for all Work is therefore: _____ 20____.

Kindly return this Notice to Proceed to the Owner in acknowledgement.

CITY OF GEORGETOWN, SOUTH CAROLINA

(Signature)

By: _____

Title: _____

Acceptance of Notice

Receipt of the above Notice to Proceed is hereby acknowledged this the _____ day of _____, 20____.

(Signature)

By: _____

Title: _____

(END OF SECTION)

NOTICE TO PROCEED
00606-1

**FRONT ST PHASE 4 UG INFRASTRUCTURE UPGRADE (T2)
CITY OF GEORGETOWN**

**SECTION 00610
APPLICATION FOR PAYMENT**

Contractor may submit other Pay Request form for Engineer's approval in lieu of the following:

Owner: City of Georgetown Contractor: _____ Contract No. _____
Pay Estimate No. _____
Period of Estimate: From _____ to _____

CONTRACT CHANGE ORDER SUMMARY				ESTIMATE
No.	Approval Date	Additions	Deductions	
				1. Original Contract \$
				2. Change Orders \$
				3. Revised Contract (1+2) ... \$
				4. Work Completed* \$
				5. Stored Materials* \$
				6. Subtotal (4+5) \$
				7. Retainage \$
				8. Previous Payments \$
				9. Amount Due (6-7-8) \$
Totals:				* Detailed breakdown attached
Net Change:				

CONTRACT TIME

Original (days): _____ On Schedule: Yes _____ No _____
Revised: _____ Starting Date: _____
Remaining: _____ Projected Completion: _____

Contractor's Certification:

The undersigned certifies that to the best of their knowledge, information, and belief the work covered by this payment estimate has been completed in accordance with the contract documents, that all amounts due subcontractors and suppliers have been paid by the Contractor for work for which previous payment estimates were issued and payments received from the Owner, and that the current payment shown herein is now due.

(Signature): _____
By: _____
Date: _____

Engineer's Certification:

The undersigned certifies that to the best of their knowledge and belief, the quantities shown in this estimate are correct and the work has been performed in accordance with the contract documents. Based on periodic but less than full-time field representation, to the best of our information the quantities, items and schedule of values, work completed and material and equipment delivered are accurate as indicated on this request for payment. Some defects or problems with construction items may not be determined until final testing and operation of the system are performed. The Engineer cannot be held liable for approval for partial payments for the installation of these items from which the evidence of defects or problems were not determined until after the request for payment was approved.

(Signature): _____
By: _____
Date: _____
Approved by Owner: (Signature): _____
By: _____
Date: _____

**FRONT ST PHASE 4 UG INFRASTRUCTURE UPGRADE (T2)
CITY OF GEORGETOWN**

**SECTION 00620
CONTRACTOR'S AFFIDAVIT**

The State of _____ Date: _____
The County of _____ The City of _____
_____ of _____
(Officer's Name) (Officer's Title) (Contractor's Name)

being duly sworn, deposed and says that _____ has furnished
(Contractor's Name)
Labor and materials entering into the **Front St Phase 4 UG Infrastructure Upgrade (T2)** dated
_____ with the City of Georgetown, South Carolina.

_____ states further that this officer has full knowledge of all
(Contractor's Name)
obligations for such labor and materials which have entered into and become part of that certain
project known and designated above, and that this officer further deposes and says that all debts and
other obligations for such labor and materials have been fully and completely paid for in good and
lawful money of the United States of America and that there are no suits for damages against them
proceeding, prospective and/or that there are no suits for damages against them proceeding,
prospective, or otherwise, in consequence of their operations on the above said project.

The said _____ will hold the Owner, the City of Georgetown
(Contractor's Name)
South Carolina, blameless of any and all mechanic's liens that may be hereafter entered or filed
for record, so as to constitute a charge against said premises for work or labor done or
materials furnished by them.

IN WITNESS HEREOF, this officer has heretofore put his hand and seal:

(Officer's Name)
I, _____, Notary Public in and for the above named County and
State do hereby certify that _____ personally know to me to be the
(Officer's Name)
affiant in the foregoing Affidavit, personally appeared before me this day and, having been duly
sworn, deposed and says the facts set forth in the above Affidavit are true and correct.

WITNESS my hand and seal this _____ day of _____ 20_____.

Notary Public for the State of _____
My Commission Expires: _____

**FRONT ST PHASE 4 UG INFRASTRUCTURE UPGRADE (T2)
CITY OF GEORGETOWN**

**SECTION 00630
CONTRACT CHANGE ORDER**

DATE: _____ PROJECT: _____
CHANGE ORDER #: _____ PROJECT #: _____

Description of and Reason for Change: _____

Itemization of Proposed Change and Basis for Payment

Original Contract Price \$ _____
Previous Change Orders \$ _____
This Change, (An Addition) (A Deduction) of \$ _____
Proposed Revised Contract Price \$ _____

Additional funds shall be provided in the following manner: _____

Extension of Contract Time Required: _____ days.

Revised Contract Completion Date: _____

Accepted by the Contractor:

By: _____ Date: _____

Recommended by the Engineer:

By: _____ Date: _____

Approved by the Owner:

By: _____ Date: _____

**FRONT ST PHASE 4 UG INFRASTRUCTURE UPGRADE (T2)
CITY OF GEORGETOWN**

**SECTION 00700
GENERAL CONDITIONS**

1. CONTRACT AND CONTRACT DOCUMENTS. The plans, specifications and addenda, hereinafter enumerated in Paragraph 1 of Supplemental General Conditions, shall form part of this contract and the provisions thereof shall be as binding upon the parties hereto as if they were herein fully set forth. The table of contents titles, heading, running headlines and marginal notes contained herein and in said documents are solely to facilitate reference to various provisions of the contract documents and in no way affect, limit or cast light on the interpretations of the provisions to which they refer.

Contents

1.	Contract and Contract Documents	24.	Construction Schedule and Payment Estimates
2.	Definitions	25.	Payments to Contractor
3.	Additional Instructions and Detail Drawings	26.	Acceptance of Work and Final Payment
4.	Shop Drawings and Samples	27.	Acceptance of Final Payment as Release
5.	Materials, Services & Facilities	28.	Payments by Contractor
6.	Contractor's Title to Materials	29.	Insurance
7.	Inspection and Testing of Materials	30.	Payment and Performance Bonds
8.	"Or Equal" Clause	31.	Assignments
9.	Patents	32.	Mutual Responsibility of Contractors
10.	Surveys, Laws, and Regulations	33.	Separate Contracts
11.	Contractor's Obligations	34.	Subcontracting
12.	Weather Conditions	35.	Engineer's Authority
13.	Protection of Work and Property, Emergency Interpretations	36.	Stated Allowances
14.	Interpretations	37.	Use of Premises and Removal of Debris
15.	Reports, Records and Data	38.	Quantities of Estimate
16.	Superintendence by Contractor	39.	Rights-of-Way and Suspension of Work
17.	Changes in Work	40.	Warranty for One Year After Completion of Contract
18.	Extras	41.	Notice and Service Thereof
19.	Time for Completion and Liquidated Damages	42.	Required Provisions Deemed Inserted
20.	Correction of Work	43.	Protection of Lives and Health
21.	Subsurface Conditions Found Different	44.	Wages and Overtime Compensation
22.	Claims for Extra Cost	45.	Prohibited Interests
23.	Right of Owner to Terminate Contract	46.	Conflicting Conditions
		47.	Indemnification

**FRONT ST PHASE 4 UG INFRASTRUCTURE UPGRADE (T2)
CITY OF GEORGETOWN**

2. DEFINITIONS. The following terms as used in this contract are respectively defined as follows:
- (a) Contractor. A person, firm or corporation with whom the contract is made by the Owner.
 - (b) Subcontractor. A person, firm or corporation supplying labor and materials, or only labor, for work at the site of the project for and under separate contract or agreement with the Contractor.
 - (c) Work on or at the Project. Work to be performed at the location of the project, including the transportation of materials and supplies to or from the location of the project by employees of the Contractor and any Subcontractor.
3. ADDITIONAL INSTRUCTIONS AND DETAIL DRAWINGS. The Contractor will be furnished additional instructions and detail drawings as necessary to carry out the work included in the Contract. The additional drawings and instructions thus supplied to the Contractor will coordinate with the Contract Documents and will be so prepared that they can be reasonably interpreted as part thereof. The Contractor shall carry on the work in accordance with the additional detail drawings and instructions. The Contractor and the Engineer will prepare jointly:
- (a) A schedule fixing the dates at which special detail drawings will be required; such drawings, if any, to be furnished by the Engineer in accordance with said schedule; and
 - (b) A schedule fixing the respective dates for the submission of shop drawings, the beginning of manufacture, testing and installation of materials, supplies, and equipment, and the completion of the various parts of the work; each such schedule to be subject to change from time to time in accordance with the progress of the work.
4. SHOP DRAWINGS AND SAMPLES. The Contractor shall submit complete manufacturer's data and drawings to the Engineer for review as specified herein. Drawings will be for the exact material or equipment to be supplied or installed and shall be clearly marked to show specific model and any options or modifications. Drawings shall be submitted within 30 days after receipt of the Purchase Order.
- 4.1 Samples. Contractor shall also submit to the Engineer for approval, all samples required by this specification. All samples will have been checked by and stamped with the approval of the Contractor, identified clearly as to material, manufacturer, any pertinent catalog numbers and the use for which intended.
 - 4.2 Deviations. At the time of each submission, Contractor shall in writing call the Engineer's attention to any deviations that the Shop Drawings or samples may have from the requirements of the Contract Document.
 - 4.3 Engineer's Review. Engineer will review and approve with reasonable promptness Shop Drawings and samples, but his review and approval shall be only for conformance with the design concept of the project and for compliance with the information given in the Contract Documents. The approval of a separate item as such will not indicate approval of the assembly in which the item functions. Contractor shall make any

**FRONT ST PHASE 4 UG INFRASTRUCTURE UPGRADE (T2)
CITY OF GEORGETOWN**

corrections required by Engineer and shall return the required number of corrected copies of Shop Drawings and resubmit new samples until approved. Contractor shall direct specific attention in writing or on resubmitted Shop Drawings to revisions other than the corrections called for by Engineer on previous submissions. Contractor's stamp of approval on any Shop Drawing or sample shall constitute a representation to Owner and Engineer that Contractor has either determined and verified all quantities, dimensions, field construction criteria, materials, catalog numbers and similar data or he assumes full responsibility for doing so, and that he has reviewed or coordinated each Shop Drawing or sample with the requirements of the work and Contract Documents.

- 4.4 Contractor's Records. Where a Shop Drawing or sample submission is required by the Specifications, no related work shall be commenced until the submission has been approved by Engineer. A copy of each approved shop drawing and each approved sample shall be kept in good order by Contractor at the site and shall be available to Engineer.
- 4.5 Contractor's Responsibility. Engineer's approval of Shop Drawings or sample shall not relieve Contractor from his responsibility for any deviations from the requirements of the Contract Documents unless Contractor has in writing called the Engineer's attention to such deviation at the time of submission and Engineer has given written approval to the specific deviation, nor shall any approval by Engineer relieve Contractor from responsibility for errors or omissions in the Shop Drawings.
5. MATERIALS, SERVICES, AND FACILITIES shall be furnished by the Contractor.
- (a) It is understood that except as otherwise specifically stated in the Contract Documents, the Contractor shall provide and pay for all materials, labor, tools, equipment, water, gas lights, power, transportation, superintendence, taxes, insurance, temporary construction of every nature, and all other services and facilities of every nature whatsoever necessary to execute, complete and deliver the work within the specified time.
- (b) Any work necessary to be performed after regular working hours, on Sundays, or legal holidays, shall be performed without additional expense to the Owner.
6. CONTRACTOR'S TITLE TO MATERIALS. No materials or supplies for the work shall be purchased by the Contractor or by any subcontractor subject to any chattel mortgage or under a conditional sale contract or other agreement by which an interest is retained by the seller. The Contractor warrants that he has good title to all materials and supplies used by him in the work, free from all liens, claims or encumbrances.
7. INSPECTION AND TESTING OF MATERIALS. Unless otherwise specifically provided for in the specifications, the inspection and testing of material and finished articles to be incorporated in the work at the site shall be made by bureaus, laboratories, or agencies approved by the Owner. The cost of such inspection and testing shall be paid by the Contractor.
- 7.1 Certification by Contractor. Where the detailed specifications call for certified copies of mill or shop tests to establish conformance of certain materials with the specifications, it shall be the responsibility of the Contractor to assure delivery of such certifications to the Owner. No materials or finished articles shall be incorporated in the work until such materials and finished articles have passed the required tests. The

**FRONT ST PHASE 4 UG INFRASTRUCTURE UPGRADE (T2)
CITY OF GEORGETOWN**

Contractor shall promptly segregate and remove rejected material and finished articles from the site of the work.

- 7.2 Guaranty. The testing and approval of materials by the laboratory, or laboratories, shall not relieve the Contractor of any of his obligations to fulfill his contract and guarantee of workmanship and materials as called for in paragraph entitled "General Warranty for One Year After Completion of Contract" herein. The Contractor may, at his option and at his own expense, cause such other tests to be conducted as he may deem necessary to assure suitability, strength, and durability of any material or finished article.
8. "OR EQUAL" CLAUSE. The phrase "or equal" shall be construed to mean that material or equipment will be acceptable only when, in the judgment of the Engineer, they are composed of parts of equal quality, or equal workmanship and finish, designed and constructed to perform or accomplish the desired result as efficiently as the indicated brand, pattern, grade, class, make or model. Written approval will be obtained from the Engineer prior to installation.
9. PATENTS. The Contractor shall hold and save the Owner and its officers, agents, servants, and employees harmless from liability of any nature or kind, including cost and expenses for, or on account of, any patented or unpatented invention, process, article, or appliance manufactured or used in the performance of the contract, including its use by the Owner, unless otherwise specifically stipulated in the Contract Documents. If the Contractor uses any design, device or material covered by letter, patent, or copyright, he shall provide for such use by suitable agreement with the Owner of such patented or copyrighted design, device or material. It is mutually agreed and understood that, with exception, the contract prices shall include all royalties or costs arising from the use of such design, device or materials, in any way involved in the work. The Contractor and/or his sureties shall indemnify and save harmless the Owner of the project from any and all claims for infringements by reason of the use of such patented or copyrighted design, device or materials or any trademark or copyright in connection with work agreed to be performed under this contract, and shall indemnify the Owner for any cost, expense or damage which it may be obliged to pay by reason of such infringement at any time during the prosecution of the work or after completion of the work.
10. SURVEYS, LAWS AND REGULATIONS. The Contractor shall comply with the following:
- 10.1 Construction staking shall be in accordance standard construction staking practice or with the requirements of Section 01050 entitled "Field Engineering".
- 10.2 Laws and Regulations. The Contractor shall keep himself fully informed of all laws, ordinances, and regulations of State, City and County in any manner affecting those engaged or employed in the work, or the materials used in the work, or in any way affecting the conduct of the work, and of all orders and decrees of bodies or tribunals having any jurisdiction or authority over same. If any discrepancy or inconsistency should be discovered in this contract, or in the drawings or specifications herein referred to, in relation to any such law, ordinance, regulation, order or decree, he shall forthwith report the same in writing to the Owner. He shall, at all times, himself observe and comply with all such existing and future laws, ordinances and regulations (to the extent that such requirements do not conflict with Federal laws or regulations) and shall protect and indemnify the Owner and its agents against any claims or liability arising from or based on the violation of any such law, ordinance, regulation, order or decree, whether by himself or by his employees.

**FRONT ST PHASE 4 UG INFRASTRUCTURE UPGRADE (T2)
CITY OF GEORGETOWN**

11. CONTRACTOR'S OBLIGATIONS. The Contractor shall, in good workmanlike manner, do and perform all work and furnish all supplies and materials, machinery, equipment, facilities, and means, except as herein otherwise expressly specified, necessary or proper to perform and complete all the work required by this contract, within the time herein specified, in accordance with provisions of this contract and said specifications, and in accordance with the plans and drawings covered by this contract and any and all supplemental plans and drawings and in accordance with the directions of the Engineer as given from time to time during the progress of the work. He shall furnish, erect, maintain and remove such construction plant and such temporary works as may be required. The Contractor shall observe, comply with, and be subject to all terms, conditions, requirements and limitation of the contract and specifications, and shall do, carry on and complete the entire work to the satisfaction of the Engineer and the Owner.
12. WEATHER CONDITIONS. In the event of temporary suspension of work or during inclement weather, or whenever the Engineer shall direct, the Contractor will, and will cause his subcontractors to, protect carefully his and their work and materials against damage or injury from the weather. If, in the opinion of the Engineer, any work or materials shall have been damaged or injured by reason of failure on the part of the Contractor or any of his Subcontractors to so protect its work, such materials shall be removed and replaced at the expense of the Contractor.
13. PROTECTION OF WORK AND PROPERTY, EMERGENCY. The Contractor shall at all times safely guard the Owner's property from injury or loss in connection with this contract. He shall at all times safely guard and protect his own work and that of adjacent property from damage. The Contractor shall replace or make good any such damage, loss or injury unless such be caused directly by errors contained in the contract or by the Owner or by his duly authorized representatives. In case of emergency which threatens loss or injury of property and/or safety of life, the Contractor will be allowed to act, without previous instructions from the Engineer, in a diligent manner. He shall notify the Engineer immediately thereafter. Any claim for compensation by the Contractor due to such extra work shall be promptly submitted to the Engineer for approval. Where the Contractor has not taken action but has notified the Engineer of an emergency threatening injury to persons or damage to the work of any adjoining property, he shall act as instructed or authorized by the Engineer. The amount of reimbursement claimed by the Contractor on account of any emergency action shall be determined in the manner provided in paragraph entitled "Changes in Work" of these specifications.
14. INTERPRETATIONS. If any person contemplating submitting a bid for the proposed contract is in doubt as to the true meaning of any part of these proposed contract documents, he may submit to the Engineer a written request for an interpretation thereof. The person submitting the request will be responsible for its prompt and actual delivery. Any interpretation of such documents will be made only by addendum duly issued, and a copy of such addendum will be mailed or delivered to each person receiving a set of such documents. The Owner will not be responsible for any other explanation or interpretation of such documents which anyone presumes to make on behalf of the Owner before expiration of the ultimate time set for the receipt of bids.
15. REPORTS RECORDS AND DATA. The Contractor shall submit to the Owner such schedule of quantities and costs, progress schedules, payrolls, reports, estimates, records and other data as the Owner may request concerning work performed or to be performed under this contract.
16. SUPERINTENDENCE BY CONTRACTOR. The Contractor shall employ only competent and skilled men on the work. The Contractor shall have competent

**FRONT ST PHASE 4 UG INFRASTRUCTURE UPGRADE (T2)
CITY OF GEORGETOWN**

Superintendent or Foreman present at all times when the work is in progress, who shall have full authority to act for the Contractor. It is understood that such representative shall be acceptable to the Engineer and shall be one who can be continued in that capacity for the particular job involved unless he ceases to be on the Contractor's payroll. The Contractor shall, upon demand from the Engineer, immediately remove any superintendent, foreman or workman whom the Engineer may consider incompetent or undesirable.

17. CHANGES IN WORK. No changes in the work covered by the approved contract documents shall be made without having prior written approval of the Owner. Charges or credits for the work covered by the approved change shall be determined by one or more, or a combination of, the following methods:
- (a) Unit bid prices previously approved.
 - (b) An agreed lump sum.
 - (c) The actual cost of:
 - 1. Labor, including foremen.
 - 2. Materials entering permanently into the work.
 - 3. The ownership or rental cost of construction plant and equipment during the time of use on the extra work.
 - 4. Power and consumable supplies for the operation of power equipment.
 - 5. Insurance.
 - 6. Social security.

To the cost under (c) there shall be added a fixed fee to be agreed upon but not to exceed 10 percent of the estimated cost of the work. The fee shall be compensation to cover the cost of supervision, overhead, bond, profit and any other general expenses.

18. EXTRAS. Without invalidating the contract, the Owner may order extra work or make changes by altering, adding to or deducting from the work, the contract sum being adjusted accordingly, and the consent of the surety being first obtained where necessary or desirable. All the work of the kind bid upon shall be paid for at the price stipulated in the proposal, and no claims for any extra work or materials shall be allowed unless the work is ordered in writing by the Owner, or the Engineer acting officially for the Owner, and the price is stated in such order. Extra work shall be performed only upon the execution of authorized change orders as set forth in the preceding paragraph.
19. TIME FOR COMPLETION AND LIQUIDATED DAMAGES. It is hereby understood and mutually agreed by and between the Contractor and the Owner that the date of beginning and the time for completion as specified in the contract of the work to be done hereunder are essential conditions of this contract; and it is further mutually understood and agreed that the work embraced in this contract shall be commenced on a date to be specified in the Notice to Proceed.
- 19.1 Regular Prosecution of Work. The Contractor agrees that said work shall be prosecuted regularly, diligently and uninterruptedly at such rate of progress as will insure full completion thereof within the time specified. It is expressly understood and agreed, by and between the Contractor and the Owner, that the time for completion of the work described herein is a reasonable time for completion of same, taking into consideration the average climatic range and usual industrial conditions prevailing in this locality.

**FRONT ST PHASE 4 UG INFRASTRUCTURE UPGRADE (T2)
CITY OF GEORGETOWN**

- 19.2 Liquidated Damages. If the Contractor shall neglect, fail, or refuse to complete the work within the time herein specified, or any proper extensions thereof granted by the Owner, then the Contractor does hereby agree, as a part consideration for the awarding of this contract, to pay to the Owner the amount specified in the contract not as a penalty but as liquidated damages for such breach of contract as hereinafter set forth, for each and every calendar day that the Contractor shall be in default after the time stipulated in the contract for completing the work. The said amount is fixed and agreed upon by and between the Contractor and the Owner because of the impracticality and extreme difficulty of fixing and ascertaining the actual damages the Owner would in such event sustain, and said amount is agreed to be the amount of damages which the Owner would sustain and said amount shall be retained from time to time by the Owner from current periodical estimates.
- 19.3 Extensions of Time for Completion. It is further agreed that time is of the essence of each and every portion of this contract and of the specifications wherein a definite and certain length of time is fixed for the performance of any act whatsoever; and where under the contractor an additional time is allowed for the completion of any work, the new time limit fixed by such extension shall be of the essence of this contract. Provided, that the Contractor shall not be charged with liquidated damages or any excess cost when the delay in completion of the work is due:
- (a) To any preference, priority or allocation order duly issued by the Government.
 - (b) To unforeseeable cause beyond the control and without the fault or negligence of the Contractor including, but not restricted to, acts of the public enemy, acts of the Owner, acts of another contractor in the performance of a contract with the Owner; fires, floods, epidemics, quarantine restrictions, strikes, freight embargoes, hurricanes, tornadoes; and
 - (c) To any delays of subcontractors or suppliers occasioned by any of the causes specified in subsections (a) and (b) of this article.

Provided, further that the Contractor shall, within seven (7) days from the beginning of such delay, unless the Owner shall grant a further period of time prior to the date of final settlement of the contract, notify the Owner in writing of the causes of delay, who shall ascertain the facts and extent of delay and notify the Contractor within a reasonable time of its decision in the matter, and grant such extension of time as the Owner shall deem suitable and just.

Normal weather conditions for the project area are taken into consideration in the time for completion of the contract; therefore, no extension of time will be extended for normal weather conditions, with the exception of hurricanes and tornadoes.

20. CORRECTION OF WORK. All work, all materials, whether incorporated in the work or not, all processes of manufacturer, and all methods of construction, shall be at all times and places subject to the inspection of the Engineer, who shall be the final judge of the quality and suitability of the work, materials, processes of manufacture, and methods of construction of the purposes for which they are used. Should they fail to meet his approval, they shall be forthwith reconstructed, made good, replaced and/or corrected, as the case may be, by the Contractor at his own

**FRONT ST PHASE 4 UG INFRASTRUCTURE UPGRADE (T2)
CITY OF GEORGETOWN**

expense. Rejected material shall immediately be removed from the site. If in the opinion of the Engineer, it is undesirable to replace any defective or damaged materials or to reconstruct or correct any portion of the work injured or not performed in accordance with the contract documents, the compensation to be paid to the Contractor hereunder shall be reduced by such amount as, in the judgment of the Engineer, shall be equitable.

21. SUBSURFACE CONDITIONS FOUND DIFFERENT. Should the Contractor encounter subsurface and/or latent conditions at the site materially differing from those shown on the plans or indicated in the specifications, he shall immediately give notice to the Engineer of such conditions before they are disturbed. The Engineer will thereupon promptly investigate the conditions, and if he finds that they materially differ from those shown on the plans or indicated in the specifications, he will at once make such changes in the plans and/or specifications as he may find necessary; any increase or decrease of cost resulting from such changes to be adjusted in the manner provided in paragraph 17 of these specifications.
- (a) Where no specific subsurface conditions are indicated or specified, no increase in cost will be considered in regards to subsurface conditions encountered.
22. CLAIMS FOR EXTRA COSTS. No claim for extra work or cost shall be allowed unless the same was done in pursuance of a written order of the Engineer, as aforesaid, and the claim presented with the first estimate after the changes or extra work is done. When work is performed under the terms of subparagraph 17(c) of these specifications, the Contractor shall furnish satisfactory bills payrolls and vouchers covering all items of cost and when requested by the Owner, give the Owner access to accounts relating thereto.
23. RIGHT OF OWNER TO TERMINATE CONTRACT. In the event that any of the provisions of this contract are violated by the Contractor or by any of his subcontractors, the Owner may serve written notice upon the Contractor and the surety of its intention to terminate the contract, such notices to contain the reasons for such intention to terminate the contract, and unless within 10 days after the serving of such notice upon the Contractor, such violation or delay shall cease and satisfactory arrangement or correction be made, the contract shall, upon the expiration of said 10 days, cease and terminate. In the event of any such termination, the Owner shall immediately serve notice thereof upon the surety and the Contractor, and the surety shall have the right to take over and perform the contract; provided, however, that if the surety does not commence performance thereof within 10 days from the date of the mailing to such surety of notice of termination, the Owner may take over the work and prosecute same to completion by the contract or by force account for the account and at the expense of the Contractor, and the Contractor and his surety shall be liable to the Owner for any excess cost occasioned thereby, and in such event the Owner may take possession of and utilize in completion the work such materials, appliances and plant as may be on the site of the work and necessary therefore. If the Contractor should die, be declared an incompetent, be declared bankrupt or insolvent, make an assignment for the benefit of creditors during the term of his contract, the Owner may terminate the contract in the manner and under the procedure set forth above with the exception that no notices to the Contractor shall be required, but in lieu thereof the Owner must make a reasonable effort to notify the estate of the Contractor, his guardian, assignee, or legal representative of the intention to terminate and fact of termination, if there is any such guardian, assignee, or legal representative at the time the Owner desires to terminate.

**FRONT ST PHASE 4 UG INFRASTRUCTURE UPGRADE (T2)
CITY OF GEORGETOWN**

24. CONSTRUCTION SCHEDULE AND PAYMENT ESTIMATES. Immediately after execution and delivery of the contract and before the first partial payment is made, the Contractor shall deliver to the Owner an estimated construction progress schedule in form satisfactory to the Owner, showing the proposed dates of commencement and completion of each of the various subdivisions of work required under the contract documents and the anticipated amount of each monthly payment that will become due the Contractor in accordance with the progress schedule.

24.1 Contractor's Payment Estimate. The Contractor shall also furnish:

- (a) A detailed payment estimate, giving a complete breakdown of the contract price; and
- (b) Periodic itemized estimates of work done for the purpose of making partial payments thereon. The costs employed in making up any of these schedules will be used only for determining the basis of partial payments and will not be considered as fixing a basis for addition to or deductions from the contract price.

24.2 Equipment Delivery Schedule. The Contractor shall also prepare a schedule of anticipated shipping dates for materials and equipment. It is intended that equipment and materials be so scheduled as to arrive at the job site just prior to time for installation to prevent excessive materials on hand for inventory and the necessity for extensive storage facilities at the job site.

25. PAYMENTS TO CONTRACTOR shall be made according to the following:

- (a) Payments to the Contractor will be made within thirty (30) days upon receipt of a duly certified approved estimate of the work performed during the preceding calendar month under this contract, but to insure the proper performance of this contract, the Owner will retain a portion of each estimate until final completion and acceptance of all work covered by this contract in accordance with the following:
 - 1) Retention of up to 10% of payment claimed until construction is complete.
- (b) In preparing the payment request, the material delivered on the site and preparatory work done may be taken into consideration.
- (c) All material and work covered by partial payments shall thereupon become the sole property of the Owner, but this provision shall not be construed as relieving the Contractor from the sole responsibility for the care and protection of materials and work upon which payments have been made or the restoration of any damaged work, or as a waiver of the right of the Owner to require the fulfillment of all the terms of the contract.

25.1 Owner's Right to Withhold Certain Amounts and Make Application Thereof. The Contractor agrees that he will indemnify and save the Owner harmless from all claims growing out of the lawful demands of subcontractors, laborers, workmen, mechanics, materialmen, and furnishers of machinery and parts thereof, equipment, power tools, and all supplies, including commissary, incurred in the furtherance of the performance of this contract. The Contractor shall, at the Owner's request, furnish satisfactory evidence that all obligations of the nature hereinabove designated have been paid,

**FRONT ST PHASE 4 UG INFRASTRUCTURE UPGRADE (T2)
CITY OF GEORGETOWN**

discharged, or waived. If the Contractor fails so to do, then the Owner may, after having served written notice on the contractor, either pay unpaid bills, of which the Owner has written notice, direct, or withhold from the Contractor's unpaid compensation a sum of money deemed reasonably sufficient to pay any and all such lawful claims until satisfactory evidence is furnished that all liabilities have been fully discharged whereupon payment to the Contractor shall be resumed in accordance with the terms of this contract, but in no event shall the provisions of this sentence be construed to impose any obligations upon the Owner to either the Contractor or his surety. In paying any unpaid bills of the Contractor, the Owner shall be deemed the agent of the Contractor, and any payment so made by the Owner shall be considered as a payment made under the contract by the Owner to the Contractor, and the Owner shall not be liable to the Contractor for any such payment made in good faith.

26. ACCEPTANCE OF WORK AND FINAL PAYMENT. Before final acceptance of the work and payment to the Contractor of the percentage retained by the Owner, the following requirements shall be complied with:
- (a) Final Inspection. Upon notice from the Contractor that his work is completed, the Engineer will make a final inspection of the work and shall notify the Contractor of all instances where his work fails to comply with the contract drawings and specifications, as well as any defects he may discover. The Contractor shall immediately make such alterations as are necessary to make the work comply with the contract drawings and specifications, and to the satisfaction of the Engineer.
 - (b) Operating Test. After the alterations for compliance with the contract drawings and specifications have been made, and before acceptance of the whole or any part of the work, it shall be subjected to test to determine that it is in accordance with the contract drawings and specifications. The Contractor shall maintain all work in first class condition for a thirty (30) day operating period after the work has been completed as a whole, the final inspection has been made, and the Engineer has notified the Contractor in writing that the work has been finished to his satisfaction. The retained percentage as provided herein will not become due or payable to the Contractor until after the thirty (30) day operating period has expired.
 - (c) Cleaning Up. Before the work is considered as complete, all rubbish and unused material due to or connected with the construction must be removed and the premises left in a condition satisfactory to the Owner. Streets, curbs, crosswalks, pavements, sidewalks, fences and other public and private property disturbed or damaged should be restored to their former condition. Final acceptance will be withheld until such work is finished.
 - (d) Liens. Final acceptance of the work will not be granted and the retained percentage will not be due or payable until the Contractor has furnished the Owner proper and satisfactory evidence under oath that all claims for labor and material employed or used in the construction of the work under this contract have been settled, and that no legal claims can be filed against the Owner for such labor or material.
 - (e) Final Payment. Upon completion of all cleaning up, alterations and repairs required by the final inspection or operating test, the satisfactory completion of the operating test, and upon submitting proper and satisfactory evidence to the Owner that all claims have been settled, the Contractor shall then prepare his final payment estimate. After review and approval of the final

**FRONT ST PHASE 4 UG INFRASTRUCTURE UPGRADE (T2)
CITY OF GEORGETOWN**

payment estimate by the Engineer and the Owner, the payment shall then become due.

27. ACCEPTANCE OF FINAL PAYMENT AS RELEASE. The acceptance by the Contractor of final payment shall be and shall operate as a release to the owner of all claims and all liability to the Contractor for all things done or furnished in connection with this work and for every act and neglect of the Owner and others relating to or arising out of this work. No payment, final or otherwise, shall operate to release the Contractor or his sureties from any obligations under this Contract or his sureties from any obligations under this contract or the performance and payment bond.
28. PAYMENTS BY CONTRACTOR. The Contractor shall pay:
- (a) For all transportation and utility services not later than the 20th day of the calendar month following that in which services are rendered;
 - (b) For all materials, tools, and other expendable equipment to the extent of ninety (90) percent of the cost thereof not later than the 20th day of the calendar month following that in which such materials, tools, and equipment are delivered at the site of the project, and the balance of the cost thereof not later than the 30th day following completion of that part of the work in or on which such materials, tools, and equipment are incorporated or used; and
 - (c) To each of his subcontractors not later than the 5th day following each payment to the Contractor, the respective amounts allowed the Contractor on account of the work performed by his subcontractors to the extent of each subcontractor's interest therein.
29. INSURANCE. The Contractor shall procure and shall maintain during the life of this contract, whether such operation be by himself or by a subcontractor or anyone directly or indirectly employed by either of them, such insurance as required by statute and/or ordinance to adequately protect the Owner from any claims or damages, including bodily injury or death, which may arise from them during operations under this contract.
- 29.1 Limits of Liability. Insurance shall be obtained for not less than the limits of liability as specified in Section 00110-Insurance Requirements.
- 29.2 Certificates of Insurance. The Contractor shall furnish the Owner, if requested, certificates showing the type, amount, class of operations covered, effective dates and dates of expiration of the policies. Such certificates shall contain substantially the following statement: "The insurance covered by this certificate will not be cancelled or materially altered except after 30 days written notice has been received by the Owner".
30. PAYMENT AND PERFORMANCE BONDS. The Contractor shall furnish a 110 percent performance bond and a 100 percent payment bond as security for the faithful performance of this contract, as security for the payment of all persons performing labor on the project under this contract and furnishing materials in connection with this contract. The performance bond and payment bond shall be in separate instruments. Before the final acceptance, each bond must be approved by the Owner.
31. ASSIGNMENTS. The Contractor shall not assign the whole or any part of this contract or any sums of money due or to become due hereunder without the written

**FRONT ST PHASE 4 UG INFRASTRUCTURE UPGRADE (T2)
CITY OF GEORGETOWN**

consent of the Owner. In case the Contractor assigns all or any part of any sums of money due or to become due under this contract, the instrument of assignment shall contain a clause substantially to the effect that is agreed that the right of the assignee in and to any sums of money due or to become due to the Contractor shall be subject to prior claims of all persons, firms and corporations for services rendered or materials supplied for the performance of the work called for in this contract.

32. MUTUAL RESPONSIBILITY OF CONTRACTORS. If through acts of neglect on the part of the Contractor, any other contractor or any subcontractor shall suffer loss or damage on the work, the Contractor agrees to settle with such other contractor or subcontractor by agreement or arbitration. If such other contractor or subcontractor shall assert any claim against the Owner on account of any damage alleged to have been sustained, the Owner shall notify the Contractor, who shall indemnify and save harmless the Owner against any such claim.
33. SEPARATE CONTRACTS. The Contractor shall coordinate his operations with those of other contractors. Cooperation will be required in the arrangement for the storage of materials and in the detailed execution of the work. The Contractor, including his subcontractor, shall keep informed of the progress and the detail work of other contractors and shall notify the Engineer immediately of lack of progress or defective workmanship on the part of other contractors. Failure of a contractor to keep informed of the work progressing on the site and failure to give notice of lack of progress or defective workmanship by others shall be construed as acceptance by him of the status of the work as being satisfactory for proper coordination with his own work.
34. SUBCONTRACTING shall comply with the following:
- (a) The Contractor may utilize the services of specialty contractors on those parts of the work that under normal contracting practices are performed by specialty subcontractors.
 - (b) The Contractor shall not award any work to any subcontractor without the prior written approval of the Owner, which approval will not be given until the Contractor submits to the Owner a written statement concerning the proposed award to the subcontractor, which statement shall contain such information as the Owner may require.
 - (c) The Contractor shall be as fully responsible to the Owner for the acts and omissions of his subcontractors, and of persons either directly or indirectly employed by them, as he is for the acts and omissions of persons employed by him.
 - (d) The Contractor shall cause appropriate provisions to be inserted in all subcontracts relative to the work to bind subcontractors to the Contractor by the terms of the General Conditions and other contract documents insofar as applicable to the work of subcontractors and to give the Contractor the same power as regards terminating any subcontract that the Owner may exercise over the Contract under any provisions of the contract documents.
 - (e) Nothing contained in this contract shall create any contractual relation between any subcontractor and the Owner.
35. ENGINEER'S AUTHORITY. The Engineer shall determine the amount, quality, acceptability and fitness of the several kinds of work and materials which are to be paid for under this contract and shall decide all questions which may arise in

GENERAL CONDITIONS

00700-12

**FRONT ST PHASE 4 UG INFRASTRUCTURE UPGRADE (T2)
CITY OF GEORGETOWN**

relation to said work and the construction thereof. The Engineer's estimates and decisions shall be final and conclusive, except as herein otherwise expressly provided. In case any question shall arise between the parties hereto relative to said contract or specifications, the determination or decision of the Engineer shall be a condition precedent to the right of the Contractor to receive any money or payment for work under this contract affected in any manner or to any extent by such question.

- 35.1 Interpretation of Drawings and Specifications. The Engineer shall decide the meaning and intent of any portion of the specifications and of any plans or drawings where the same may be found obscure or be in dispute. Any differences or conflicts in regard to their work that may arise between the Contractor under this contract and other contractors performing work for the Owner shall be adjusted and determined by the Engineer.
36. ALLOWANCES: N/A.
37. USE OF PREMISES AND REMOVAL OF DEBRIS. The Contractor expressly undertakes at his own expense:
- (a) To take every precaution against injuries to persons or damage to property.
 - (b) To store his apparatus, materials, supplies, and equipment in such orderly fashion at the site of the work as will not unduly interfere with the progress of his work or the work of any other contractors.
 - (c) To place upon the work or any part thereof only such loads as are consistent with the safety of that portion of the work.
 - (d) To clean up frequently all refuse, rubbish, scrap materials, and debris caused by his operations, to the end that at all times the site of the work shall present a neat, orderly and workmanlike appearance.
 - (e) Before final payment to remove all surplus material, falsework, temporary structures, including foundations thereof, plant of any description and debris of every nature resulting from his operations, and to put the site in a neat, orderly condition.
 - (f) To effect all cutting, fitting or patching of his work required to make the same conform to the plans and specifications, and, except with the consent of the Engineer, not to cut or otherwise alter the work of any other contractor.
38. QUANTITIES OF ESTIMATE. The estimated quantities of work to be done and materials to be furnished under this contract, shown in any of the documents, including the proposal, are given for use in comparing bids, and the right is specially reserved except as herein otherwise specifically limited, to increase or diminish them as may be deemed reasonably necessary or desirable by the Owner to complete the work contemplated by this contract, and such increase or diminution shall in no way vitiate this contract, nor shall any such increase or diminution give cause for claims or liability for damages.
39. RIGHT-OF-WAY AND SUSPENSION OF WORK. The Owner shall furnish all land and rights-of-way necessary for the carrying out of this contract and the completion of the work herein contemplated, and will use due diligence in acquiring said land and rights-of-way as speedily as possible. But it is possible that all lands and rights-of-way may not be obtained as herein contemplated before construction begins, in which event the Contractor shall begin his work upon such land and rights-of-way as the Owner may have previously acquired, and no claim for

**FRONT ST PHASE 4 UG INFRASTRUCTURE UPGRADE (T2)
CITY OF GEORGETOWN**

damages whatsoever will be allowed by reason of the delay in obtaining the remaining lands and rights-of-way.

Should the Owner be prevented or enjoined from proceeding with the work, or from authorizing its prosecution, either before or after the commencement, by reason of any litigation or by reason of its ability to procure any lands or rights-of-way for said work, the Contractor shall not be entitled to make or assert claim for damage by reason of said delay or to withdraw from the contract except by consent of the Owner; but time for completion of the work will be extended to such time as the Owner determines will compensate for the time lost by such delay, such determination to be set forth in writing.

40. GENERAL WARRANTY FOR ONE YEAR AFTER COMPLETION OF CONTRACT. For a period of at least one year after the completion of the contract, the Contractor warrants the fitness and soundness of all work done and materials and equipment put in place under the contract, and neither the final certificate of payment nor any provision in the Contract Documents nor partial or entire occupancy of the premises by the Owner shall constitute an acceptance of work not done in accordance with the Contract Documents or relieve the Contractor of liability in respect to any express warranties or responsibility for faulty materials or workmanship. The Contractor shall remedy any defects in the work and pay for any damage to other work resulting there from, which shall appear within a period of one year from the date of final acceptance of the work, unless a longer period is specified. The Owner will give notice of observed defects with reasonable promptness. This warranty period shall be extended as necessary to include additional warranty periods required by permitting agencies.
41. NOTICE AND SERVICE THEREOF. Any notice to any Contractor from the Owner relative to any part of this contract shall be in writing and considered delivered and the service thereof completed, when said notice is posted by registered mail to said Contractor or his authorized representative on the work or is deposited in the regular United States Mail in a sealed, postage prepaid envelope and the receipt thereof is acknowledged by the Contractor.
- 41.1 Owner's Notice. All papers required to be delivered to the Owner shall be delivered as indicated in Section 00800 entitled Supplemental General Conditions.
42. REQUIRED PROVISIONS DEEMED INSERTED. Each and every provision of law and clause required by law to be inserted in this contract shall be deemed to be inserted herein, and the contract shall be read and enforced as though it were included herein, and if through mistake or otherwise any such provision is not inserted or is not correctly inserted, then upon the application of either party the contract shall forthwith by physically amended to make such insertion or correction.
43. PROTECTION OF LIVES AND HEALTH. In order to protect the lives and health of his employees under the contract, the Contractor shall comply with all pertinent provisions of the "Manual of Accident Prevention in Construction" issued by the Associated General Contractors of America, Inc., and shall maintain an accurate record of all cases of death, occupational disease, and injury requiring medical attention or causing loss of time from work, arising out of and in the course of employment on work under the contract. The Contractor alone shall be responsible for the safety, efficiency and adequacy of his plant, appliances and methods, and for any damage that may result from their failure or their improper construction, maintenance or operation.
44. WAGES AND OVERTIME COMPENSATION. The Contractor and each of his subcontractors shall comply with all applicable State and local laws or ordinances

**FRONT ST PHASE 4 UG INFRASTRUCTURE UPGRADE (T2)
CITY OF GEORGETOWN**

with respect to the hours worked by laborers and mechanics engaged in work on the project and with respect to compensation for overtime.

45. PROHIBITED INTERESTS. No official of the Owner, who is authorized in such capacity and on behalf of the Owner to negotiate, make, accept or approve or to take part in negotiating, making, accepting, or approving any architectural, engineering, inspection, construction, or material supply contract or any subcontract in connection with the construction of the project, shall become directly or indirectly interested personally in this contract or in any part hereof. No officer, employee, architect, attorney, engineer, or inspector of and on behalf of the Owner to exercise any legislative, executive, supervisory or other similar functions in connection with the construction of the project shall become directly or indirectly interested personally in this contract or in any part hereof, any material supply contract, subcontract, insurance contract, or any other contract pertaining to the project.
46. CONFLICTING CONDITIONS. Any provisions in any of the Contract Documents which may be in conflict or inconsistent with any of the paragraphs in these General Conditions shall be void to the extent of such conflict or inconsistency.
47. INDEMNIFICATION
- 47.1 The CONTRACTOR will indemnify and hold harmless the OWNER, the ENGINEER and their agents and employees from and against all claims, damages, losses and expenses including attorney's fees arising out of or resulting from the performance of the WORK, provided that any such claims, damage, loss or expense is attributable to bodily injury, sickness, disease or death, or to injury to or destruction of tangible property including the loss of use resulting there from; and is caused in whole or in part by any negligent or willful act of omission of the CONTRACTOR and SUBCONTRACTOR, anyone directly or indirectly employed by any of them or anyone for whose acts any of them may be liable.
- 47.2 In any and all claims against the OWNER or the ENGINEER, or any of their agents or employees, by an employee of the CONTRACTOR, any SUBCONTRACTOR, anyone directly employed by any of them, or anyone for whose acts any of them may be liable, the indemnification obligation shall not be limited in any way by limitation on the amount or type of damages, compensation or benefits payable by or for the CONTRACTOR or any SUBCONTRACTOR under workmen's compensation acts, disability benefit acts or other employee benefits acts.
- 47.3 The obligation of the CONTRACTOR under this paragraph shall not extend to the liability of the ENGINEER, its agents or employees arising out of the preparation or approval of maps, drawings, opinions, reports, surveys, change orders, design or specifications.

(END OF SECTION)

GENERAL CONDITIONS
00700-15

**FRONT ST PHASE 4 UG INFRASTRUCTURE UPGRADE (T2)
CITY OF GEORGETOWN**

**SECTION 00800
SUPPLEMENTARY CONDITIONS**

1. WORKING HOURS

The Contractor is allowed to work during regular working hours from 7:00 AM to 6:00 PM unless warranted due to emergency conditions or scheduled outages.

Weekend work must be approved in advance by the Owner.

2. ELECTRICAL OUTAGES

The Contractor is advised that electrical outages will need to be scheduled with the Owner and all customers. The work must be scheduled in a manner to minimize the electric power outage time. If overnight outages are necessary for any customers, the Contractor shall notify the Owner at least 5 days before the outage is expected to begin and at least 25 hours before the power is disconnected.

3. BUSINESS LICENSE AND PERMITS

The selected contractor shall be required to obtain a per-job city business license. Contact the Finance Department, at 843-545-4007, to obtain a City business license. Business fee is based on the total contract amount.

**FRONT ST PHASE 4 UG INFRASTRUCTURE UPGRADE (T2)
CITY OF GEORGETOWN**

4. PROJECT SCHEDULE OF EVENTS

The following is the schedule of events listed in the order of occurrence, showing the major milestones from issuance of the RFB to the contract completion:

No.	PROJECT MILESTONE EVENTS	DATE	LOCAL TIME
1	Request for Construction Bid (RFB) Release	Tues, February 17, 2026	
2	Non-mandatory Pre-Bid Meeting to be held at Francis Marion Park on Front St, Georgetown SC	Tues, February 24, 2026	10:30 AM
3	Deadline for questions – Must be submitted online via BidNet Direct	Fri, February 27, 2026	3:00 PM
4	Deadline for addenda to be posted to the City's website, www.georgetownsc.gov, under “Bids”	Wed, March 4, 2026	3:00 PM
5	Bid opening date	Wed, March 11, 2026	3:00 PM
6	City Council approval (Tentative)	Thurs, March 19, 2026	
7	Construction Notice of Award (Tentative)	Tues, March 31, 2026	
8	Construction Notice to Proceed (Tentative)	Mon, April 13, 2026	
9	Construction Contract Completion (90 calendar days after NTP)	Mon, July 13, 2026	
10	Project Closeout (30 calendar days after completion)	Thurs, August 13, 2026	

When the Purchasing Division is closed due to force majeure, bid openings will be postponed to the same time on the next official business day.

(END OF SECTION)

**FRONT ST PHASE 4 UG INFRASTRUCTURE UPGRADE (T2)
CITY OF GEORGETOWN**

SECTION 00900

DRAWING INDEX

<u>TITLE</u>	<u>DRAWING NO.</u>
TITLE SHEET	G4001
SIMPLE PLAN VIEW NEW	E4001
ELECTRICAL PLAN EXISTING	E4002
ELECTRICAL PLAN NEW	E4003
CONSTRUCTION SEQUENCE	E4004
BILL OF MATERIALS	E4005
MISCELLANEOUS DETAILS	E4011
MANHOLE T2	E4014
PULLBOX 3	E4023
PULLBOX 4	E4024
PULLBOX 5	E4025
PULLBOX 6	E4026
PULLBOX 7	E4027
PULLBOX 8	E4028
CONDUIT AND CABLE SCHEDULE	E4040
CABLE TAGS	E4041
TRANSFORMER DETAILS	E4050
ONE-LINE DIAGRAM EXISTING	E4100
ONE-LINE DIAGRAM NEW	E4101
STRUCTURAL GENERAL NOTES	S4001
TRANSFORMER PAD	S4002

(END OF SECTION)

DRAWING INDEX
00900-1

**FRONT ST PHASE 4 UG INFRASTRUCTURE UPGRADE (T2)
CITY OF GEORGETOWN**

**SECTION 01000
LOCAL VENDOR PREFERENCE OPTION –
MANDATORY VENDOR SUBMITTAL FORM**

Local Vendor Preference Option

1. A vendor shall be deemed a Local Georgetown City/County vendor for the purposes of this Section if such vendor is an individual, partnership, association or corporation that is authorized to transact business within the State, maintains an office in Georgetown County, and maintains a representative inventory or commodities within the City/County on which the bid is submitted, and has paid all taxes and business license fees duly assessed.
2. This option allows the lowest local bidder whose bid is within five-percent (5%) of the lowest non-local Bidder to match the bid submitted by the non-local Bidder and thereby be awarded the contract. This preference shall apply only when (a) the total dollar purchase is \$10,000 or more; (b) the vendor has a physical business address located and operating within the limits of Georgetown County and has been doing business in the City/County for a period of twelve (12) months or more; and (c) the vendor provides proof of payment of all applicable Georgetown City/County taxes, business license and fees if so requested.
3. Should the lowest responsible and responsive Georgetown City/County bidder not exercise its right to match the bid as granted herein, the next lowest qualified Georgetown City/County bidder shall have that right and so on. The right to match the non-Georgetown City/County bidder's bid shall be exercised within 24 hours of notification.
4. In order to qualify for the local preference authorized by this Section, the vendor seeking same shall be required to submit with its bid a statement containing relevant information which demonstrates compliance with the provisions of this Section. This statement shall be on the "MANDATORY VENDOR SUBMITTAL" form included in this bid document. Failure to provide such affidavit at the time the bidder submits its bid shall constitute a waiver of any claim for preference.
5. For all contracts for architecture, professional engineering, or other professional services governed by Section 2-187, Professional and Construction Services, the City shall include the local business status of a firm among the factors considered when selecting which firms are "most highly qualified." In determining which firm is the "most qualified" for purposes of negotiating a satisfactory contract, preference shall be given to a local business where all other relevant factors are equal.
6. Local preference shall not apply to the following categories of contracts:
 - (a) Goods or services provided under a cooperative purchasing agreement or similar "piggyback" contract;
 - (b) Contracts for professional services except as provided for in Section 2-187 above;

**FRONT ST PHASE 4 UG INFRASTRUCTURE UPGRADE (T2)
CITY OF GEORGETOWN**

- (c) Purchases or contracts which are funded, in whole or in part, by a governmental or other funding entity, where the terms and conditions of receipt of the funds prohibit the preference;
- (d) Purchases or contracts made pursuant to a noncompetitive award process, unless otherwise provided by this section; or
- (e) Any bid announcement which specifically provides that the general local preference policies set forth in this section are suspended due to the unique nature of the goods or services sought, the existence of an emergency as found by either
City Council or City Administrator, or where such suspension is, in the opinion of the City Attorney, required by law.

FRONT ST PHASE 4 UG INFRASTRUCTURE UPGRADE (T2)
CITY OF GEORGETOWN



MANDATORY VENDOR SUBMITTAL FORM

I certify that [Company Name] _____
is a **Resident Bidder** of Georgetown City/County as defined in the City of Georgetown
Ordinance Chapter 2 Administration, Article IV Procurement, Section 2-185, and our principal
place of business is _____ [City and State].

I certify that [Company Name] _____ Sumter Utilities, Inc.
is a **Non-Resident Bidder** of Georgetown City/County as defined in the City of Georgetown
Ordinance Chapter 2 Administration, Article IV Procurement, Section 2-185, and our principal
place of business is _____ Sumter, South Carolina _____ [City and State].

(X) 

Derek O'Bradovich, President
Signature of Company Officer

(END OF SECTION)

**FRONT ST PHASE 4 UG INFRASTRUCTURE UPGRADE (T2)
CITY OF GEORGETOWN**

**SECTION 01001
SUMMARY OF THE WORK**

Project Description

The work in this contract consists of the upgrade and replacement of the downtown Front Street electric power distribution system in Georgetown, SC; including all its appurtenances, site work, and any off-site improvement required or necessary; shown on the drawings; all in accordance with the Bidding and Contract Requirements, Specifications and the accompanying Drawings, excepting only those items specifically shown, noted or specified as not in contract.

Scope of Services

The successful candidate must be able to provide materials and labor to perform work at the Georgetown Front St electric power distribution system in Georgetown, SC. The work will be performed for the City of Georgetown, SC.

The project includes but is not limited to the below described work as indicated on the drawings and in the project specifications. Details and proper sequence of work to be completed is shown in the drawings.

- Transfer customers served from pull boxes PB8 (809, 807, and 805) and PB7 (803 and 801) to existing transformer T3 via PB9
- Transfer customers served from pull box PB6 to existing transformer T1B via PB5
- Transfer services served directly from T2 to MHT2. A new conduit exit will be required from MHT2.
- De-energize existing transformer T2
- Demo T2 transclosure, transformers, and concrete pad
- Provide and install any new underground conduits for new T2 pad mount transformers and junction cabinet as indicated on the drawings.
- Provide and install any new underground conduits for services from manhole MHT2 as indicated on the drawings
- Provide and install cast-in-place or precast transformer foundation as indicated on the drawings. Install new pad mount transformers T2 and junction cabinet JCT2
- Clean and drain water out of manhole MHT2 and pull boxes PB8, PB7, PB6, PB5 and PB4. Clean and inspect manhole and pull box interior surfaces. Advise the City of any concerns about integrity.
- Remove 3-phase primary conductor from T2 to junction cabinet JCT3 and from T2 to T1B.
- Install and test new 3-phase primary conductor from junction cabinet JCT2 to JCT3 and from JCT2 to T1B
- Remove existing 3-phase secondary conductors from T2 to PB7, from PB7 to PB8, from T2 to PB6, from PB6 to PB5, and from PB5 to PB4.
- Remove existing cable wall supports and cable support brackets in manhole and pull boxes and replace with new cable wall supports and cable support brackets. Remove existing ground wire and replace with new ground wire and rods. Make ground connections to new cable wall supports.
- Install and test new parallel 3-phase conductors and parallel 1-phase conductors from T2 to PB7, from PB7 to PB8, From T2 to PB6, from PB6 to PB5, from PB5 to PB4, from PB4 to PB3, and from PB3 to PB2 as shown on the drawings.
- Connect existing underground service cables to the new secondary underground cables.
- Install all ground rods, ground conductors, and connections at all equipment.
- Provide and install name labels for all new pad-mounted transformers and cable tags for all cables as indicated on the drawings.
- Perform and document medium voltage cable tests as specified.

**SUMMARY OF THE WORK
01001-1**

**FRONT ST PHASE 4 UG INFRASTRUCTURE UPGRADE (T2)
CITY OF GEORGETOWN**

- Provide all required warning road signs, DOT traffic cones, pedestrian sidewalk safety guards etc. required to maintain a safe working environment as specified herein. Provide all traffic control as necessary.
- Provide all necessary equipment and permitting required for confined space entry.

The work must be scheduled in phases and in a manner to minimize the electric power outage time. The Contractor shall discuss and coordinate all outages with the Owner and notify the Owner at least 5 days before the outage is expected to begin and at least 24 hours before the power is disconnected.

The new pad mounted transformers and materials listed on drawing E4005 will be provided by the Owner. The transformers and other material shall be retrieved from the Owner's warehouse, transported, set in place and electrically connected by the Contractor. The Contractor is responsible for all materials not identified on E4005 including all conduit, labels, cable taping, cable tags, etc.

Site Work will include:

- Grading levelling, sloping, seeding as required around new pad-mounted transformer and removal of existing transclosure and concrete pad.
- Grade levelling, asphalt patching, paver repair, curb repair and seeding as required around any excavation.

Location of Underground Utilities

Obtain digging permits prior to start of excavation, and comply with installation requirements for locating and marking underground utilities. Verify existing utility locations indicated on contract drawings, within area of work.

Verify the elevations of existing piping, utilities, and any type of underground obstruction not indicated or specified to be removed in locations to be traversed by piping, ducts, and other work to be conducted or installed.

Owner Furnished Equipment

The City will furnish the following materials and equipment for installation by the Contractor:

- Pad mounted transformers, medium and low voltage cables, cable connectors, junction cabinets, pedestals, wall supports and brackets, grounding material, and connection hardware.

Salvage Material and Equipment

Items designated by the Engineer to be salvaged remain the property of the City. Segregate, itemize, deliver and off-load the salvaged property at the City designated storage area located within 5 miles of the construction site.

Provide a salvage plan, listing material and equipment to be salvaged, and their storage location. Maintain property control records for material or equipment designated as salvage. Use a system of property control that is approved by the Engineer. Store and protect salvaged materials and equipment until disposition by the Engineer.

(END OF SECTION)

SUMMARY OF THE WORK

01001-2

**FRONT ST PHASE 4 UG INFRASTRUCTURE UPGRADE (T2)
CITY OF GEORGETOWN**

**SECTION 01002
INCORPORATION OF GENERAL CONDITIONS AND SUPPLEMENTARY
GENERAL CONDITIONS**

All requirements of the General Conditions and Supplementary General Conditions apply to all sections of the specifications and drawings for this project.

(END OF SECTION)

**INCORPORATION OF GENERAL CONDITIONS AND SUPPLEMENTARY
GENERAL CONDITIONS**

01002-1

**FRONT ST PHASE 4 UG INFRASTRUCTURE UPGRADE (T2)
CITY OF GEORGETOWN**

**SECTION 01003
OPERATION MANUALS**

An operation manual shall be compiled by the contractor containing instructions, maintenance manuals, test reports and warranties for all material and equipment incorporated in the work.

At the completion of the work, the Contractor shall provide 5 sets of manufacturer's literature referencing specifications, operation, and maintenance for all equipment, combined in individual loose-leaf binders: 4 sets shall be provided to the CITY and 1 set shall be provided to the ENGINEER.

(END OF SECTION)

**FRONT ST PHASE 4 UG INFRASTRUCTURE UPGRADE (T2)
CITY OF GEORGETOWN**

**SECTION 02110
SITE PRESERVATION**

GENERAL

RELATED DOCUMENTS

Drawings and general provisions of Contract, including General and Supplementary Conditions and other applicable Specification Sections, apply to this Section.

SUMMARY

This Section includes the following:

- Protection of trees
- Disposal of Undesirable Material Off-Site

Related Sections: The following Sections contain requirements that relate to this Section:

- Seeding Disturbed Areas (02900)

EXISTING CONDITIONS

Site Conditions:

- Contractor shall visit the site, familiarize himself with actual conditions and verify existing conditions in the field. Contractor shall notify the Engineer immediately upon finding any discrepancies between the existing site conditions and information shown on the plans.
- Record Information: Existing conditions are shown on the Demolition plan and are incorporated into Construction Documents.

PROTECTION

Bench Marks: Maintain carefully all bench marks, monuments and other reference points. If disturbed or destroyed, replace as directed by the Engineer.

Existing Utilities: Should any functioning underground utilities be uncovered during the work, the Contractor shall promptly notify the Engineer immediately in writing. The Contractor shall be held responsible for any damage to underground or overhead utility services and shall immediately repair and restore services at no additional cost to the Owner.

Existing Trees and Vegetation: Protect existing trees and other vegetation indicated to remain in place, against unnecessary cutting, breaking or skinning of roots, skinning and bruising of bark, smothering of trees by stockpiling construction materials or excavated materials within drip line, excess foot or vehicular traffic, or parking of vehicles within drip line. Provide temporary guards to protect trees and vegetation to be left standing. Any vegetation designated to remain which is damaged by construction work shall be replaced with new vegetation of the same kind by the contractor responsible for such damage.

EXECUTION

CLEARING AND GRUBBING

Disposition: Objects and materials to be removed shall be removed cleanly, completely, and legally disposed of offsite at the expense of the Contractor. Salvageable topsoil to be reused on this project shall be stored at a location designated on site by Owner. Excess topsoil shall be disposed of off-site at the expense of the Contractor.

**SITE PRESERVATION
02110-1**

**FRONT ST PHASE 4 UG INFRASTRUCTURE UPGRADE (T2)
CITY OF GEORGETOWN**

Limits of Work: Generally, all existing trees, whether shown on the Drawings or not, shall not be removed.

Coordination: Loose sticks, roots, branches, or other debris shall not be left on the site. The Contractor shall avoid the admixture of foreign matter to the topsoil.

PROTECTION OF EXISTING TREES TO REMAIN AND UNDISTURBED AREAS

Fencing: Trees to remain shall be protected by temporary fences constructed of wood, wire mesh, and metal as required, to provide complete protection. Erect fences at perimeter of spread of trees to protect feeding roots.

Cutting: Do not cut low-hanging branches on trees to be saved, unless approved by the ENGINEER. Any such branches which must be cut to eliminate obstructions shall be pruned by experienced treemen. Any such cuts, or any accidental injuries to the bark or trunk shall be immediately and properly trimmed.

Grading: Grades surrounding trees to remain shall be warped up or down, where possible, between existing grades of root area and new finished grades. Where fills under 2' occur, the fill shall consist of broken stone or washed gravel, for a distance of 3' from the trunk in all directions, the remaining fill being of light, friable topsoil. Do not disturb root system.

Prohibited Work: Stripping of topsoil, cutting, filling, or dumping of materials, will not be permitted within the spread of branches of trees to remain. Burning of combustible material is not permitted on the OWNER'S property

PROTECTION OF EXISTING SIDEWALKS, WALKWAYS, PARKING LOTS, AND PUBLIC ROADS.

The Contractor shall take preventative measures to ensure existing concrete sidewalks within the project working area are not chipped, stained, cracked, scratched or otherwise damaged. If any concrete sidewalk is damaged, the damaged area shall be repaired as specified.

The Contractor shall take preventative measures to ensure existing walkways, parking lots and public roads within the project working area are not damaged. If any damage occurs the Contractor shall repair the damaged area as specified. This includes gravel or paved parking lots and walkways beyond the street sidewalks.

(END OF SECTION)

**FRONT ST PHASE 4 UG INFRASTRUCTURE UPGRADE (T2)
CITY OF GEORGETOWN**

**SECTION 02900
SEEDING DISTURBED AREAS**

GENERAL

RELATED DOCUMENTS

Drawings and general provisions of Contract, including General and Supplementary Conditions and other applicable Specification Sections, apply to this Section.

SUMMARY

All existing grass areas which are disturbed or denuded during the project by either trenching or otherwise shall be seeded as required and as shown on the Drawings and specified.

STORAGE OF MATERIALS

Store all materials in weather proof place with care to prevent loss of effectiveness or intrusion of foreign materials.

MATERIALS

Lime: Lime shall be ground limestone (Dolomite) containing not less than 85% total carbonates and shall be ground to such fineness that 50% will pass through a 100-mesh sieve and 90% will pass through a 20-mesh sieve.

Fertilizer: Commercial fertilizers shall be 16% Nitrogen, 4% Phosphate, 8% potash, and 0-20-0 Superphosphate, and shall conform to the applicable State of South Carolina Board of Agriculture fertilizer laws. It shall be uniform in composition, dry and free flowing, and shall be delivered to the site in the original unopened containers, each bearing the manufacturer's guaranteed analysis. Any fertilizer which becomes caked or otherwise damaged will not be acceptable.

Permanent Seed: Seed shall be a 50/50 blend of Rebel and Falcon fescues and shall have a minimum purity of 98%, minimum germination of 90%, and be free of noxious weed seeds. Seed shall be delivered to the site in sealed standard size containers, showing weight, analysis, name of vendor and germination test. Seed which has become wet, moldy, or otherwise damaged will not be accepted.

Topsoil: Topsoil shall be from project stockpile and shall be prepared by the contractor as to be free of sub-soil roots, branches, stones over 2" in diameter and other extraneous material. Waste shall be disposed of offsite by the Contractor.

Water: Water shall be potable and will be provided by the Contractor.

EXECUTION

SITE CONDITIONS

Unless otherwise approved by the Engineer, all other site work required by this Contract shall be complete and in place before grassing operations are begun. Work may be completed in parts if so requested by the Contractor and approved by the Engineer.

The Contractor shall locate, or have located, all public and private underground utilities which may affect work in this Section. Any utility damaged by work under this Section shall be repaired promptly by the Contractor. Repairs shall be done to the satisfaction of the respective utility Owner and all costs shall be borne by the Contractor.

**SEEDING DISTURBED AREAS
02900-1**

**FRONT ST PHASE 4 UG INFRASTRUCTURE UPGRADE (T2)
CITY OF GEORGETOWN**

PREPARATION OF AREAS TO BE SEEDED AND DENUDED AREAS

Prior to redistribution of topsoil and seeding, verify that all denuded areas are at required subgrade and scarify to a 4" depth and pulverize until the surface is smooth, friable and of a uniformly fine texture.

Remove stones and foreign material over 2" in any direction and grade for positive drainage.

Prepared topsoil shall be redistributed to a 4" minimum depth, over denuded areas to be planted with grass, ground covers, shrubs and trees. Pulverize until the surface is smooth, friable and of a uniformly fine texture.

All equipment shall be of size and type required for specified preparation of all areas to be seeded and shall be approved by the Engineer. Upon approval of the Engineer, the method of preparation may be varied by the Contractor under his responsibility to provide optimum conditions for seeding.

SEEDING AND FERTILIZATION

The following rates shall be applied:

- Lime shall be applied to all areas at the rate of 90 pounds per 1000 sq. ft.
- 16-4-0 fertilizer shall be applied to all areas at the rate of 20 pounds per 1000 sq. ft.
- 0-20-0 superphosphate shall be evenly distributed in all areas at the rate of 12 lbs. per 1000 sq. ft.

Fescue seed shall be evenly distributed over the prepared seed bed of proposed lawn areas, at the rate of 6 pounds per 1000 sq. ft. of area. Apply annual rye grass at the rate of 2 lbs. per 1000 sq. ft. only if seeded between October 15 and February 15.

Asphalt tack-coat shall be applied in the method and quantity required to hold mulch together and prevent displacement by wind or surface drainage.

All areas shall be seeded, and fertilized evenly at the rate specified, rolled once with a roller weighing not less than 100 pounds per lineal foot, tack coated as required, and watered thoroughly with a fine spray.

ACCEPTANCE

The Engineer shall be the sole judge as to whether or not the seeded areas are acceptable.

GUARANTEE FOR PERMANENT GRASS: The Contractor shall guarantee a live and vigorous stand of permanent grass at the time of acceptance of the work consisting of 90 percent coverage minimum of seeded grass. (No bare spots greater than 5 square feet, the total of which shall not exceed 2% of the lawn area).

CLEANUP: Upon completion of initial seeding work in this Section, the Contractor shall remove all equipment and materials not required for maintenance. All debris and waste material resulting from work in this Section shall be removed from the site.

(END OF SECTION)

**FRONT ST PHASE 4 UG INFRASTRUCTURE UPGRADE (T2)
CITY OF GEORGETOWN**

**SECTION 03100
CONCRETE FORMWORK**

GENERAL

RELATED DOCUMENTS

The general provisions of the Contract, including General and Supplementary Conditions and General Requirements, apply to the work specified in this Section.

DESCRIPTION OF WORK

Work Included This Section:

Work shall consist of providing all concrete formwork, form coatings and accessories required to complete the formwork for the pad mounted transformer pads as shown on the drawings.

Related Work Specified Elsewhere:

- Concrete Reinforcement (03200)
- Cast-In-Place / Ready-Mix Concrete (03300)

QUALITY ASSURANCE

Codes and Standards:

Unless otherwise shown or specified, design, construct, erect, maintain, and remove forms and related structures for cast-in-place concrete work in compliance with the American Concrete Institute Standard ACI 347, "Recommended Practice for Concrete Formwork".

MATERIALS

Forms for Exposed Finish Concrete:

Unless otherwise shown or specified, construct formwork for exposed concrete surfaces with plywood, metal, metal-framed plywood-faced or other acceptable panel type materials to provide continuous straight, smooth exposed surfaces. Furnish in largest practicable sizes to minimize number of joints and conform to joint system shown on drawings. Provide form material with sufficient thickness to withstand pressure of newly placed concrete without bow or deflection.

Plywood for formwork for smooth exterior concrete shall be plywood complying with U. S. Products Standard PS-1 "B-B High Density Overlaid Concrete Form" Class I. Plywood for all other exposed concrete formwork shall not be less than 5/8", 5-ply Douglas fir plywood especially processed to resist moisture and conforming to Plyform Class I, B-B Ext-DFPA of U. S. Product Standard PS 1-66.

Forms for Unexposed Finish Concrete:

Form concrete surfaces which will be unexposed in the finished structure with plywood, boards, metal or other acceptable material. Provide lumber that is dressed on at least 2 edges and 1 side for tight fit.

ACCESSORIES

Form Ties: Shall be reviewed by the Engineer. Spreaders or wire ties shall not be used. Snap ties will be permitted except on exposed exterior surfaces where pull ties will be required. Ties shall have a minimum working strength when fully assembled of at least 3,000 pounds and shall be adjustable in

**CONCRETE FORMWORK
03100-1**

**FRONT ST PHASE 4 UG INFRASTRUCTURE UPGRADE (T2)
CITY OF GEORGETOWN**

length as to permit complete tightening of forms and of such type as to leave no metal closer than 1-1/2" to the surface. They shall not be fitted with any lugs, cones, washers or other devices to act as a spreader within the forms or for any other purpose which will leave a hole or depression larger than 7/8" in diameter or a depression in excess of 1/8" back of the exposed surface. Furnish a sample of each exposed type.

Corner Formers: Corner formers shall be plastic with 3/4" radius equivalent to "Green Streak" corner formers, manufactured by:

- Grace Construction Products
- EFCO Corp.
- Vinylex Corporation

Form Releasing Agent: Form releasing agent Commercial Formulation Compounds with a maximum VOC of 350 Mg/L shall be non-staining "Debond" as manufactured by L & M Construction Chemicals or "Nox-Crete" Form Coating by Nox-Crete Chemical Co. or approved equivalent.

STORAGE OF MATERIALS

All materials shall be properly stored and protected from damage during time of non-use.

EXECUTION

DESIGN FORMWORK

Design, erect, support, brace and maintain formwork so that it will safely support all vertical and lateral loads that might be applied until such loads can be supported by the concrete structure. Carry vertical and lateral loads to the ground by the formwork system and by the in-place construction that has attained adequate strength for that purpose.

Design formwork to be readily removable without impact, shock or damage to the Cast-In-Place concrete surfaces and adjacent materials.

Side forms of footings may be omitted and concrete placed directly against the neat excavation only when requested by the Contractor and accepted by the Engineer. When omission of forms is accepted, provide additional concrete required beyond the minimum design profiles and dimensions of the footings as detailed to maintain 3 inch cover at all sides of reinforcing steel. Earth forms shall be wetted (damp), but not muddy before concrete is placed.

FORM CONSTRUCTION

General Requirements for Form Construction:

Construct forms to the exact sizes, shapes, lines and dimensions shown, and as required to obtain accurate alignment, location, grades, level and plumb work in the finished structures. Provide for openings offsets, sinkages, keyways, recesses, moldings, rustications, reglets, chamfers, blocking, screeds, bulkheads, anchorages and insets to obtain the required finishes. Formwork shall be constructed sufficiently tight to prevent leakage of concrete; to securely brace, shore and safely support construction loads and to prevent displacements.

CONTRACTOR shall be fully responsible for adequacy of formwork units. CONTRACTOR shall also be responsible for forms in conjunction with any structural steel work. Forms shall support loads that might be applied until concrete structure can support such loads and shall maintain their dimensional and surface correctness to produce members required by drawings.

FRONT ST PHASE 4 UG INFRASTRUCTURE UPGRADE (T2) CITY OF GEORGETOWN

Provide temporary openings where interior area of formwork is inaccessible for cleanout, for inspection before concrete placement and for placement of concrete. Securely brace temporary openings and set tightly to forms to prevent the loss of concrete mortar. Locate temporary openings on forms in as inconspicuous location as possible, consistent with the requirements of the work.

Provide openings in concrete formwork to accommodate work of other trades. Size and location of openings, recesses and chases are the responsibility of the trade requiring such items. Accurately place and securely support items to be built into forms.

Carefully form intersecting planes to provide true, clean-cut corners, with edge grain of plywood not exposed as form for concrete.

Form Ties:

Provide factory fabricated, adjustable-length, removable or snap-off metal form ties, designed to prevent form deflection and to prevent spalling concrete surfaces upon removal. Ties that are to be removed from the wall shall be coated with cup grease or other approved material to facilitate removal.

The rods that are to be entirely removed from the walls shall be loosened 24 hours after the concrete is poured. All but a sufficient number of ties to hold the forms in place may be removed at that time.

Provide shores and struts with positive means of adjustment capable of taking up form work settlement during concrete placing operations, using wedges or jacks or a combination thereof. Provide trussed supports when adequate foundations for shores and struts cannot be secured.

Preparation of Form Surfaces: Coat the contact surfaces of forms with a form-coating compound before reinforcement is placed. Provide commercial formulation form-coating compounds that will not bond with, stain, nor adversely affect concrete surfaces and will not impair subsequent treatment of concrete surfaces requiring bond or adhesion, or impede the wetting of surfaces to be cured with water or curing compounds. Thin form-coating compounds only with the thinning agent of the type and in amount and under the conditions of the form-coating compound manufacturer's directions. Do not allow excess form coating material to accumulate in the forms or to come into contact with concrete surfaces or reinforcing steel against which fresh concrete will be placed. Apply in compliance with manufacturer's instructions. In no case shall the reinforcing steel and inserts be coated with this material.

INSTALLATION

Shall be in accordance with ACI 301 with particular attention being given to tolerances.

Inserts, Sleeves and Fastening Devices:

- See drawings, coordinate with all other trades and other Sections of the Specifications for extent, location, and details of materials to be embedded or placed in concrete.
- Sufficient time between erection of forms and placing of concrete shall be given to the various trades to permit the proper installation of their work. All devices installed in the forms shall be maintained in position and protected until the concrete pouring is completed.
- The installation of inserts, miscellaneous pipe sleeves, hangers, ties, angle supports, anchors, bolts, angle guards, dowels, thimbles, anchor slots, reglets blocking, nailers, and other materials for attachment of their work to concrete shall be under this Section under the supervision and at the location furnished by the trades requiring these devices. Do not install sleeves in any concrete footing, slab, or pier without Engineer's approval.

**FRONT ST PHASE 4 UG INFRASTRUCTURE UPGRADE (T2)
CITY OF GEORGETOWN**

Control Joints: See Section 03300 for treatment of control and construction joints, including wood screeds, metal keyways and sawcuts. Locate as indicated within the drawings and specifications.

Edge Forms and Screeds Strips For Slabs: Set edge forms or bulkheads and intermediate screed strips for slabs to obtain required elevations and contours in the finished slab surface. Provide and secure units to support types of screeds required.

Removal of Forms: Forms shall be removed in accordance with requirements of ACI Manual of Concrete Practice without damage to concrete and in a manner to insure complete safety to the structure. Leave shoring in place until concrete member will safely support its own weight plus any live loads that may be placed upon it or until the concrete has obtained a strength acceptable to the Engineer. Upon removal of forms, the Contractor shall notify the Engineer in order that a review of the newly stripped surfaces may be made prior to patching. Should the forms be removed sooner than 7 days after pouring, the resulting exposed surfaced shall be sprayed with the curing compound specified in Section 03300.

RESHORING

Reshoring for the purpose of early form removal, where permitted by the Engineer, shall be performed so that at no time will large areas of new construction be required to support their own weight. When reshores are required, they shall be installed not later than the end of the working day in which stripping occurs.

While reshoring is underway, no live loads shall be permitted on the new construction. Reshores shall be tightened to carry their required loads but they shall not be over tightened so that the new construction is overstressed. Reshores shall remain in place until the concrete has reached its specified 28 day strength, unless otherwise specified or permitted.

RE-USE OF FORMS

Clean and repair the surfaces of forms that are to be reused in the work, except that split, frayed, delaminated or otherwise damaged form facing material will not be acceptable. Apply new form coating compound material to all concrete contact form surfaces as specified for new formwork.

When forms are extended for successive concrete placement, thoroughly clean surfaces, remove fins and laitance and tighten forms to close all joints. Align and secure all joints to avoid offsets. Do not use "Patched" forms for exposed concrete surfaces, except as acceptable to the Engineer. Any form works deemed unacceptable by Engineer shall be rejected.

(END OF SECTION)

**FRONT ST PHASE 4 UG INFRASTRUCTURE UPGRADE (T2)
CITY OF GEORGETOWN**

**SECTION 03200
CONCRETE REINFORCEMENT**

GENERAL

RELATED DOCUMENTS

The general provisions of the Contract, including General and Supplementary Conditions and General Requirements, apply to the work specified in this Section.

DESCRIPTION OF WORK

Work Included This Section: Work shall include providing the following and all other items related to concrete reinforcement:

- Metal Reinforcement
- Metal Accessories
- Plastic Accessories

Related Work Specified Elsewhere:

- Concrete Formwork (03100)
- Cast-In-Place / Ready-Mix Concrete (03300)

QUALITY ASSURANCE

Standard Reference:

The Standard Reference shall be the ACI 301, hereinafter called ACI; The American Welding Society Structural Welding Code and ASTM Specifications as listed.

The current edition of the following standard reference shall apply to the work of this Section. CONTRACTOR shall be responsible for obtaining latest edition.

1. ASTM A82: Specifications for Cold Drawn Steel Wire for Concrete Reinforcement.
2. ASTM A185: Specification for Welded Steel Wire Fabric For Concrete Reinforcement.
3. ASTM A615: Specification for Deformed and Plain Billet-Steel Bars for Concrete Reinforcement.
4. ACI 301: Specifications for Structural Concrete for Buildings.
5. ACI 315: Manual for Standard Practice for Detailing Reinforced Concrete Structures.
6. ACI 318: Building Code Requirements for Reinforced Concrete.
7. AWS D1.1: Structural Welding Code.

SUBMITTALS

Shop Drawings:

Drawings shall be prepared under supervision of a registered Professional Engineer in the State of South Carolina. Shop Drawings shall show for fabrication, bending, and placement of concrete reinforcement. Comply with ACI SP-66, "ACI Detailing Manual," showing bar schedules, stirrup spacing, diagrams of bent bars, bar lists, and arrangement of concrete reinforcement. placing plans, bending details, and bar lists. Wall reinforcing shall be shown in elevation. Location and arrangement of sleeves, inserts, accessories, etc. shall be clearly indicated.

**CONCRETE REINFORCEMENT
03200-1**

**FRONT ST PHASE 4 UG INFRASTRUCTURE UPGRADE (T2)
CITY OF GEORGETOWN**

Reinforcing bars shall not be erected or set in place before the approved shop drawings have been returned to the Contractor.

Only shop drawings completely checked by the Fabricator and General Contractor will be considered by the Designer. Approval of shop drawings is for design only. Contractor is responsible for dimensions, quantities, and coordination with other trades.

As specified and in accordance with Section 03300-1 "Cast-In-Place Concrete". Submit copies of Manufacturer's printed technical literature and performance data on the fiber reinforcing proposed for use in project.

STORAGE OF MATERIALS:

Reinforcing steel delivered to the job, and not immediately placed in forms, shall be stored under cover and protected from mud, rusting, oil, grease or distortion.

CLEANING:

At the time of placing concrete, reinforcing shall be free from rust, oil, corrosion, scale or other coatings that will destroy or reduce bond.

PRODUCTS

MATERIALS

Steel Reinforcement: Steel Reinforcement shall be deformed type bars conforming to ASTM A 615. Reinforcement shall be manufactured from new billet steel of American manufacture, and shall conform to ASTM A 615, Grade 60 with a yield strength of 60,000 psi.

Welded Wire Fabric: Welded Wire Fabric shall conform to the requirements of ASTM A 185. Size and gauge shall be as indicated on Drawings.

Steel Accessories: Include all spacers, ties, chairs, bolsters and other devices required to properly support and fasten reinforcing steel in place in accordance with the requirements of ACI 315. Chairs and other accessories shall have plastic-tipped feet. Location and types of supports shall be shown on shop drawings. Accessories and elements required by other trades shall be shown on shop drawings, furnished by those trades, and installed under this Section.

Shop Fabrication: Reinforcing steel shall be fabricated to shapes and dimensions indicated on the Drawings and in compliance with applicable provisions of ACI 315 and ACI 318. Bars shall be bent cold in the shop and no bars shall be bent in the field.

INSPECTION

The Contractor must examine the conditions under which concrete reinforcement is to be placed, and notify the Engineer in writing of unsatisfactory conditions. Do not proceed with the work until unsatisfactory conditions have been corrected in a manner acceptable to the Contractor.

INSTALLATION

Placement:

- Reinforcement shall be placed accurately in accordance with the Drawings and adequately secured in position with metal chairs, spacers with ties and other devices to properly support and fasten in accordance with ACI.

**FRONT ST PHASE 4 UG INFRASTRUCTURE UPGRADE (T2)
CITY OF GEORGETOWN**

- Steel reinforcement, at the time concrete is placed, shall be free from rust, scale, mud or other coatings that will destroy or reduce bond. Bars with kinks or bends not shown on the plans shall not be used. Steel reinforcement shall be accurately placed in accordance with the plans. Secure in position with not less than 16-gauge annealed wire or suitable clips at intersections. Hold securely the required distance from the forms by concrete or metal chairs and spacers. Nails shall not be driven into outside forms or support reinforcement.

Splicing: Splices and offsets of reinforcing shall be in accordance with ACI 318 and as shown and noted on the drawings. All reinforcing splices shall have a minimum lap of 36 bar diameters unless noted otherwise. All reinforcement shall be accurately placed in the forms and securely tied in position prior to placement of concrete.

Wire Fabric: Install as indicated on Drawings. Lap all joints 6" and wire securely. Extend mesh to within 2" of all sides and ends of slabs.

(END OF SECTION)

**FRONT ST PHASE 4 UG INFRASTRUCTURE UPGRADE (T2)
CITY OF GEORGETOWN**

**SECTION 03300
CAST-IN-PLACE / READY-MIX CONCRETE**

GENERAL

RELATED DOCUMENTS

The general provisions of the Contract, including General and Supplementary Conditions and General Requirements, apply to the work specified in this Section.

DESCRIPTION OF WORK

Work Included This Section:

Work of this Section shall include furnishing all labor and materials required to provide all cast-in-place / ready-mix concrete.

All structural concrete work shall be done in accordance with the applicable sections of ACI 301, Specifications for Structural Concrete. The project superintendent and concrete foreman shall have a copy of the ACI Field Reference Manual, SP-15, on the Project site and shall be familiar with the contents thereof.

Related Work Specified Elsewhere:

- Concrete Formwork (03100)
- Concrete Reinforcement (03200)

CODES AND STANDARDS

Standards and Specifications: All standards and specifications mentioned in this Section refer to the latest edition, unless otherwise noted, and shall be considered as a part of the specification except where otherwise specified herein.

ASTM Standards:

- C33 Specification for Concrete Aggregates.
- C94 Specification for Ready-Mixed Concrete.
- C150 Specification for Portland Cement.
- C233 Testing Air-Entraining Admixtures for Concrete.
- C260 Specification for Air-Entraining Admixture for Concrete.
- C309 Specification for Liquid Membrane Forming Compounds for Curing Concrete.
- C494 Standard Specification for Chemical Admixtures for Concrete.

DELIVERY AND PROTECTION OF MATERIALS

Deliver ready-mixed concrete in compliance with requirements set forth in ASTM C-94, except as otherwise indicated.

Severe Weather Provisions: Protect concrete from physical damage or reduced strength due to weather extremes. In cold weather, comply with ACI 306.

**CAST-IN-PLACE / READY-MIX CONCRETE
03300-1**

**FRONT ST PHASE 4 UG INFRASTRUCTURE UPGRADE (T2)
CITY OF GEORGETOWN**

PRODUCTS

MATERIALS

Portland Cement: ASTM C150, Type 1. Use one brand of cement throughout project. No Fly Ash shall be used.

Aggregate: The maximum size of coarse aggregate for reinforced concrete shall be 3/4 the distance between bars, or 1/5 narrowest dimension between forms, or 1/3 the depth of slabs, whichever is the smallest. Provide aggregates from a single source for exposed concrete.

Normal Weight Aggregates: ASTM C33.

Water: Water shall be potable and free from deleterious amounts of oils, acids, alkalis, and organic matter. (Drinkable).

Ready-Mix Concrete: The concrete shall be mixed in accordance with the recommendations of the National Ready-Mix Concrete Association. Attention is called to Paragraph 14 of ASTM C94; the certification in its entirety, as called for by this paragraph shall be obtained by the Contractor and kept on file at the Project site.

INSPECTION OF WORK BEFORE PLACING

The Contractor shall inspect the work to receive cast-in-place concrete for deficiencies which would prevent proper execution of the finished work. Do not proceed with placing until such deficiencies are corrected. Do not place concrete on earth until the fill or excavation has been compacted as set forth under Applicable Sections of the Specifications.

Do not place concrete in forms until all foreign matter has been removed from the forms and the reinforcing steel is in proper position for the placement of concrete.

PLACEMENT OF CONCRETE

Preparation of Equipment and Place of Deposit: Before placing concrete, all equipment for mixing and transporting concrete shall be cleaned, all debris and ice removed from place to be occupied by the concrete, forms thoroughly wetted, except in freezing weather, or coated, and reinforcement thoroughly cleaned of ice or other coatings. Water shall be removed from place of deposit before concrete is placed.

Mixing: Concrete shall be mixed until uniform distribution of materials is obtained, and shall be discharged completely before the mixer is recharged. Ready-mix concrete shall be mixed and delivered in accordance with requirements set forth in the "Standard Specifications for Ready-Mixed Concrete", ASTM C94.

Conveying: Concrete shall be conveyed from mixer to place of deposit by methods which will prevent separation or loss of materials. Equipment for chute, pumping, or pneumatically conveying concrete shall be of such size and design as to assure practically a continuous flow of concrete at delivery without separation of materials.

Depositing: Concrete shall be deposited as near as practical to its final position to avoid segregation due to rehandling or flowing. Depositing shall proceed at such a rate that concrete is at all times plastic and flows readily into space between the bars. No concrete that has partially set or been contaminated by foreign material shall be deposited, nor shall retempered concrete be used. Maximum free-fall of concrete shall not exceed distance specified in ACI 301 and no deviation from the specifications will be permitted. Pouring, when once started, shall be carried on as a continuous operation until the pad is completed. The top surfaces shall be generally level. All concrete shall be thoroughly compacted by

CAST-IN-PLACE / READY-MIX CONCRETE

03300-2

**FRONT ST PHASE 4 UG INFRASTRUCTURE UPGRADE (T2)
CITY OF GEORGETOWN**

suitable means during placing, and thoroughly worked around reinforcement and embedded fixtures and into corners of forms.

CURING AND PROTECTION

Concrete shall be allowed to cure for 7 days.

(END OF SECTION)

**CAST-IN-PLACE / READY-MIX CONCRETE
03300-3**

**FRONT ST PHASE 4 UG INFRASTRUCTURE UPGRADE (T2)
CITY OF GEORGETOWN**

**SECTION 03400
PRECAST CONCRETE STRUCTURES**

GENERAL

RELATED DOCUMENTS

The general provisions of the Contract, including General and Supplementary Conditions and General Requirements, apply to the work specified in this Section.

DESCRIPTION OF WORK

Work Included This Section:

Work of this Section shall include furnishing all labor and materials required to provide all precast concrete structures. Precast concrete underground structures may be provided in lieu of cast-in-place subject to the requirements specified below. Precast units must be the product of a manufacturer regularly engaged in the manufacture of precast concrete products, including precast manholes.

GENERAL

Precast concrete structures must have the same accessories and facilities as required for cast-in-place structures. Likewise, precast structures must have plan area and clear heights not less than those of cast-in-place structures. Concrete materials and methods of construction must be the same as for cast-in-place concrete construction, as modified herein.

Slope in floor may be omitted provided precast sections are poured in reinforced steel forms. Concrete for precast work must have a 28-day compressive strength of not less than 4000 psi. Structures may be precast to the design and details indicated for cast-in-place construction, precast monolithically and placed as a unit, or structures may be assembled sections, designed and produced by the manufacturer in accordance with the requirements specified.

Structures must be identified with the manufacturer's name embedded in or otherwise permanently attached to an interior wall face.

DESIGN FOR PRECAST STRUCTURES

ACI 318M. In the absence of detailed on-site soil information, design for the following soil parameters/site conditions:

Angle of Internal Friction (ϕ) = 30 degrees

Unit Weight of Soil (Dry) = 110 pcf, (Saturated) = 130 pcf

Coefficient of Lateral Earth Pressure (K_a) = 0.33

Ground Water Level = 3 feet below ground elevation

Vertical design loads must include full dead, superimposed dead, and live loads including a 30 percent magnification factor for impact. Live loads must consider all types and magnitudes of vehicular (automotive, industrial, or aircraft) traffic to be encountered. The minimum design vertical load must be for H20 highway loading per AASHTO HB-17.

Horizontal design loads must include full geostatic and hydrostatic pressures for the soil parameters, water table, and depth of installation to be encountered. Also, horizontal loads imposed by adjacent structure foundations, and horizontal load components of vertical design

**PRECAST CONCRETE STRUCTURES
03400-1**

**FRONT ST PHASE 4 UG INFRASTRUCTURE UPGRADE (T2)
CITY OF GEORGETOWN**

loads, including impact, must be considered, along with a pulling-in iron design load of 6000 pounds.

Each structural component must be designed for the load combination and positioning resulting in the maximum shear and moment for that particular component.

Design must also consider the live loads induced in the handling, installation, and backfilling of the manholes. Provide lifting devices to ensure structural integrity during handling and installation.

CONSTRUCTION

Structure top, bottom, and wall must be of a uniform thickness of not less than 6 inches. Thin-walled knock-out panels for designed or future duct bank entrances are not permitted. Provide quantity, size, and location of duct bank entrance windows as directed, and cast completely open by the precaster.

Size of windows must exceed the nominal duct bank envelope dimensions by at least 12 inches vertically and horizontally to preclude in-field window modifications made necessary by duct bank misalignment. However, the sides of precast windows must be a minimum of 6 inches from the inside surface of adjacent walls, floors, or ceilings.

Form the perimeter of precast window openings to have a keyed or inward flared surface to provide a positive interlock with the mating duct bank envelope. Provide welded wire fabric reinforcing through window openings for in-field cutting and flaring into duct bank envelopes.

Provide additional reinforcing steel comprised of at least two No. 4 bars around window openings. Provide drain sumps a minimum of 12 inches in diameter and 4 inches deep for precast structures.

JOINTS

Provide tongue-and-groove joints on mating edges of precast components. Shiplap joints are not allowed. Design joints to firmly interlock adjoining components and to provide waterproof junctions and adequate shear transfer.

Seal joints watertight using preformed plastic strip conforming to ASTM C990. Install sealing material in strict accordance with the sealant manufacturer's printed instructions. Provide waterproofing at conduit/duct entrances into structures, and where access frame meets the top slab, provide continuous grout seal.

(END OF SECTION)

**FRONT ST PHASE 4 UG INFRASTRUCTURE UPGRADE (T2)
CITY OF GEORGETOWN**

**SECTION 16010
BASIC ELECTRICAL REQUIREMENTS**

GENERAL

RELATED DOCUMENTS

Drawings and general provisions of Contract, including General and Supplementary Conditions and Division 1 Specification Sections, apply to this and the other sections of Division 16.

SUMMARY

This Section includes general administrative and procedural requirements for electrical installations. The following administrative and procedural requirements are included in this Section to expand the requirements specified in Section 00700 – GENERAL CONDITIONS.

- Shop Drawings.
- Record documents.
- Operation manuals.
- Shipment.

SUBMITTALS

General: Follow the procedures specified in Section 00700, Subsection 4 - SHOP DRAWINGS AND SAMPLES

RECORD DOCUMENTS

The Contractor shall maintain an orderly and adequate file of up-to-date copies of all Engineer's drawings and specifications, manufacturer's prints and specifications, and other contract documents and supplementary data. In addition, the Contractor shall maintain a continuous record of all field changes by means of a set of drawings marked to indicate current "as-built" conditions. This "as-built" set of drawings shall be available for check by the Engineer in order for him to ascertain that it is being kept current. At the conclusion of work, the "as-built" drawings and other engineering data, accurately and neatly marked with field changes, shall be submitted to the Engineer in the required number of copies. The "as-built" drawings and data shall include all revisions to the work made under this Contract, including those made by subcontractors. The installed conditions shall include:

- Major raceway systems underground duct banks, size and location, for both exterior and interior; locations of control devices; distribution and branch electrical circuitry; and fuse and circuit breaker size and arrangements.
- Wood Poles, Electrical Pull Boxes, Man Holes, Junction Cabinets, Junction Boxes, Pedestals, Pad-mounted Transformers, and Equipment locations (exposed and concealed), dimensioned from prominent building lines.
- Approved substitutions, Contract Modifications, and actual equipment and materials installed.
- A wiring log as described in Section 16195.

MAINTENANCE MANUALS

Prepare maintenance manuals in accordance with Section 01003 – OPERATION MANUAL. In addition to the requirements specified in Section 01003, include the following information for equipment items:

- Description of function, normal operating characteristics and limitations, performance curves, engineering data and tests, and complete nomenclature and commercial numbers of replacement parts.

**BASIC ELECTRICAL REQUIREMENTS
16010-1**

FRONT ST PHASE 4 UG INFRASTRUCTURE UPGRADE (T2) CITY OF GEORGETOWN

- Manufacturer's printed operating procedures to include start-up, break-in, and routine and normal operating instructions; regulation, control, stopping, shutdown, and emergency instructions; and summer and winter operating instructions.
- Maintenance procedures for routine preventative maintenance and troubleshooting; disassembly, repair, and reassembly; aligning and adjusting instructions.
- Servicing instructions and lubrication charts and schedules.

DELIVERY, STORAGE, AND HANDLING

Deliver products to the project properly identified with names, model numbers, types, grades, compliance labels, and other information needed for identification.

ROUGH-IN

Verify final locations for rough-ins with field measurements and with the requirements of the actual equipment to be connected.

Refer to equipment specifications in Divisions 2 through 16 for rough-in requirements.

ELECTRICAL INSTALLATIONS

General: Sequence, coordinate, and integrate the various elements of electrical systems, materials, and equipment. Comply with the following requirements:

- Verify all dimensions by field measurements.
- Coordinate the installation of required supporting devices and sleeves to be set in poured-in-place concrete and other structural components, as they are constructed.
- Sequence, coordinate, and integrate installations of electrical materials and equipment for efficient flow of the Work.
- Install systems, materials, and equipment to conform with approved submittal data, including coordination drawings, to greatest extent possible. Conform to arrangements indicated by the Contract Documents. Where coordination requirements conflict with individual system requirements, refer conflict to the Engineer.
- Install systems, materials, and equipment level and plumb, and parallel.
- Install electrical equipment to facilitate servicing, maintenance, and repair or replacement of equipment components. As much as practical, connect equipment for ease of disconnecting, with minimum of interference with other installations.
- The Contractor should limit all outages to customers to four (4) hours at a time wherever possible.

CUTTING AND PATCHING

Perform cutting, fitting, and patching of electrical equipment and materials required to:

1. Uncover Work to provide for installation of ill-timed Work.
2. Remove and replace defective Work.
3. Remove and replace Work not conforming to requirements of the Contract Documents.
4. Remove samples of installed Work as specified for testing.
5. Install equipment and materials in existing structures.
6. Upon written instructions from the Engineer, uncover and restore Work to provide for Engineer observation of concealed Work.

Cut, remove, and legally dispose of selected electrical equipment, components, and materials as indicated, including but not limited to removal of electrical items indicated to be removed and items made obsolete by the new Work.

**FRONT ST PHASE 4 UG INFRASTRUCTURE UPGRADE (T2)
CITY OF GEORGETOWN**

Protect the structure, furnishings, finishes, and adjacent materials not indicated or scheduled to be removed. Protection of Installed Work: During cutting and patching operations, protect adjacent installations.

Provide and maintain temporary partitions or dust barriers adequate to prevent the spread of dust and dirt to adjacent areas.

(END OF SECTION)

**FRONT ST PHASE 4 UG INFRASTRUCTURE UPGRADE (T2)
CITY OF GEORGETOWN**

**SECTION 16050
BASIC ELECTRICAL MATERIALS AND METHODS**

GENERAL

RELATED DOCUMENTS

Drawings and general provisions of Contract, including General and Supplementary Conditions and Division 1 Specification Sections, apply to this Section.

Requirements specified in Section 16010 "Basic Electrical Requirements" apply to this Section.

SUMMARY

This Section includes limited scope general construction materials and methods for application with electrical installations as follows:

- Selective demolition including dismantling electrical materials and equipment made obsolete by these installations.
- Excavation for underground utilities and services, including underground raceways, vaults, and equipment.
- Miscellaneous metals for support of electrical materials and equipment.

DEFINITIONS

The following definitions apply to excavation operations:

- Additional Excavation: Where excavation has reached required subgrade elevations, if unsuitable bearing materials are encountered, continue excavation until suitable bearing materials are reached. The Contract Sum may be adjusted by an appropriate Contract Modification.
- Subbase: as used in this Section refers to the compacted soil layer used in pavement systems between the subgrade and the pavement base course material.
- Subgrade: as used in this Section refers to the compacted soil immediately below the slab or pavement system.
- Unauthorized excavation consists of removal of materials beyond indicated subgrade elevations or dimensions without specific direction from the Engineer.

SUBMITTALS

General: Submit the following in accordance with General Conditions.

- Product data for the following products:
 1. 15 kV elbow connectors, arresters, splices, and terminators
 2. 600 V submersible connectors and terminal lugs
 3. 15 kV underground primary cable
 4. 600 V secondary cable
 5. Cable support brackets and cable clamps
- Shop drawings detailing fabrication and installation for metal fabrications and anchorage for electrical materials and equipment.
- Schedules indicating proposed methods and sequence of operations for selective demolition prior to commencement of Work. Include coordination for shut-off of electrical service.

**BASIC ELECTRICAL MATERIALS AND METHODS
16050-1**

FRONT ST PHASE 4 UG INFRASTRUCTURE UPGRADE (T2) CITY OF GEORGETOWN

PROJECT CONDITIONS

Conditions Affecting Selective Demolition: The following project conditions apply:

- Protect adjacent materials indicated to remain.
- Locate, identify, and protect electrical services passing through demolition area and serving other areas outside the demolition limits. Maintain services to areas outside demolition limits. When services must be interrupted, install temporary services for affected areas.
- Conditions Affecting Excavations: The following project conditions apply:
 1. Maintain and protect existing building services which transit the area affected by selective demolition.
 2. Existing Utilities: Locate existing underground utilities in excavation areas. If utilities are indicated to remain, support and protect services during excavation operations.
 3. Remove existing underground utilities indicated to be removed.
 4. Uncharted or Incorrectly Charted Utilities: Contact utility owner immediately for instructions.
 5. Provide temporary utility services to affected areas. Provide minimum of 48-hour notice to Engineer prior to utility interruption.
 6. Use of explosives is not permitted.

SEQUENCE AND SCHEDULING

Coordinate the shut-off and disconnection of electrical service with the Owner and the utility company.

Notify the Engineer at least 5 days prior to commencing demolition operations.

PRODUCTS

SOIL MATERIALS

Subbase Material: Naturally or artificially graded mixture of natural or crushed gravel, crushed stone, crushed slag, or natural or crushed sand.

Drainage Fill: Washed, evenly graded mixture of crushed stone, or crushed or uncrushed gravel, with 100 percent passing a 1-1/2-inch sieve, and not more than 5 percent passing a No. 4 sieve.

Backfill and Fill Materials: Materials complying with ASTM D2487 soil classification groups GW, GP, GM, SM, SW, and SP; free of clay, rock, or gravel larger than 2 inches in any dimension; debris; waste; frozen materials; and vegetable and other deleterious matter.

EXECUTION

WORK RULES

All electrical work shall be performed in compliance with ANSI C2 "National Electrical Safety Code", Part 4. Clothing and equipment while working on or near energized lines, parts, or equipment shall be arc rated for a minimum of 4 cal/cm² incident energy.

EXAMINATION

Examine substrates, areas, and conditions for compliance with requirements for installation tolerances and other conditions affecting installation. Do not proceed with installation until unsatisfactory conditions have been corrected.

FRONT ST PHASE 4 UG INFRASTRUCTURE UPGRADE (T2) CITY OF GEORGETOWN

SELECTIVE DEMOLITION

General: Demolish, remove, demount, and disconnect abandoned electrical materials and equipment.

Disposal and Cleanup: Remove from the site and legally dispose of demolished materials and equipment not indicated to be salvaged.

EXCAVATION

Slope sides of excavations to comply with local codes and ordinances. Shore and brace as required for stability of excavation.

Shoring and Bracing: Establish requirements for trench shoring and bracing to comply with local codes and authorities. Maintain shoring and bracing in excavations regardless of time period excavations will be open.

Remove shoring and bracing when no longer required. Where sheeting is allowed to remain, cut top of sheeting at an elevation of 30 inches below finished grade elevation.

Install sediment and erosion control measures in accordance with local codes and ordinances.

Dewatering: Prevent surface water and subsurface or ground water from flowing into excavations and from flooding project site and surrounding area.

- Do not allow water to accumulate in excavations. Remove water to prevent softening of bearing materials. Provide and maintain dewatering system components necessary to convey water away from excavations.
- Establish and maintain temporary drainage ditches and other diversions outside excavation limits to convey surface water to collecting or run-off areas. Do not use trench excavations as temporary drainage ditches.

Material Storage: Stockpile satisfactory excavated materials where directed, until required for backfill or fill. Place, grade, and shape stockpiles for proper drainage.

- Locate and retain soil materials away from edge of excavations. Do not store within drip-line of trees indicated to remain.
- Remove and legally dispose of excess excavated materials and materials not acceptable for use as backfill or fill.
- Excavation for Underground Vaults and Electrical Structures: Conform to elevations and dimensions shown within a tolerance of plus or minus 0.10 foot; plus a sufficient distance to permit placing and removal of concrete formwork, installation of services, other construction, and for inspection.
 1. Excavate, by hand, areas within drip-line of large trees. Protect the root system from damage and dry-out. Maintain moist conditions for root system and cover exposed roots with burlap. Paint root cuts of 1 inch in diameter and larger with emulsified asphalt tree paint.
 2. Take care not to disturb bottom of excavation. Excavate by hand to final grade just before concrete reinforcement is placed.

Trenching: Excavate trenches for electrical installations as follows:

- Excavate trenches to the uniform width, sufficiently wide to provide ample working room and a minimum of 6 to 9 inches clearance on both sides of raceways and equipment.

**FRONT ST PHASE 4 UG INFRASTRUCTURE UPGRADE (T2)
CITY OF GEORGETOWN**

- Excavate trenches to depth indicated or required.
- Limit the length of open trench to that in which installations can be made and the trench backfilled within the same day.
- Where rock is encountered, carry excavation below required elevation and backfill with a layer of crushed stone or gravel prior to installation of raceways and equipment. Provide a minimum of 6 inches of stone or gravel cushion between rock bearing surface and electrical installations.
- **NO TRENCHES SHALL BE LEFT OPEN OVER NIGHT!**

Cold Weather Protection: Protect excavation bottoms against freezing when atmospheric temperature is less than 35 deg F.

- Backfilling and Filling: Place soil materials in layers to required subgrade elevations for each area classification listed below, using materials specified in Part 2 of this Section.
 1. Under walks and pavements, use a combination of subbase materials and excavated or borrowed materials.
 2. Under building slabs, use drainage fill materials.
 3. Under piping and equipment, use subbase materials where required over rock bearing surface and for correction of unauthorized excavation.
 4. For raceways less than 30 inches below surface of roadways, provide 4-inch-thick concrete base slab support. After installation of raceways, provide a 4-inch thick concrete encasement (sides and top) prior to backfilling and placement of roadway subbase.
 5. Other areas, use excavated or borrowed materials.
- Backfill excavations as promptly as work permits, but not until completion of the following:
 1. Inspection, testing, approval, and locations of underground utilities have been recorded.
 2. Removal of concrete formwork.
 3. Removal of shoring and bracing, and backfilling of voids.
 4. Removal of trash and debris.

Placement and Compaction: Place backfill and fill materials in layers of not more than 8 inches in loose depth for material compacted by heavy equipment, and not more than 4 inches in loose depth for material compacted by hand-operated tampers.

Before compaction, moisten or aerate each layer as necessary to provide optimum moisture content. Compact each layer to required percentage of maximum dry density or relative dry density for each area classification specified below. Do not place backfill or fill material on surfaces that are muddy, frozen, or contain frost or ice.

Place backfill and fill materials evenly adjacent to structures, piping, and equipment to required elevations. Prevent displacement of raceways and equipment by carrying material uniformly around them to approximately same elevation in each lift.

Compaction: Control soil compaction during construction, providing minimum percentage of density specified for each area classification indicated below.

- Percentage of Maximum Density Requirements: Compact soil to not less than the following percentages of maximum density for soils which exhibit a well-defined moisture-density relationship (cohesive soils), determined in accordance with ASTM D 1557 and not less than the following percentages of relative density, determined in accordance with ASTM D 2049, for soils which will not exhibit a well-defined moisture-density relationship (cohesionless soils).

**FRONT ST PHASE 4 UG INFRASTRUCTURE UPGRADE (T2)
CITY OF GEORGETOWN**

- Areas Under Structures, Building Slabs and Steps, Pavements: Compact top 12 inches of subgrade and each layer of backfill or fill material to 90 percent maximum density for cohesive material, or 95 percent relative density for cohesionless material.
- Areas Under Walkways: Compact top 6 inches of subgrade and each layer of backfill or fill material to 90 percent maximum density for cohesive material, or 95 percent relative density for cohesionless material.
- Other Areas: Compact top 6 inches of subgrade and each layer of backfill or fill material to 85 percent maximum density for cohesive soils, and 90 percent relative density for cohesionless soils.
- Moisture Control: Where subgrade or layer of soil material must be moisture conditioned before compaction, uniformly apply water. Apply water in minimum quantity necessary to achieve required moisture content and to prevent water appearing on surface during, or subsequent to, compaction operations.
- Subsidence: Where subsidence occurs at electrical installation excavations during the period 12 months after Substantial Completion, remove surface treatment (i.e., pavement, lawn, or other finish), add backfill material, compact to specified conditions, and replace surface treatment. Restore appearance, quality, and condition of surface or finish to match adjacent areas.

(END OF SECTION)

**FRONT ST PHASE 4 UG INFRASTRUCTURE UPGRADE (T2)
CITY OF GEORGETOWN**

**SECTION 16100
RACEWAY, BOXES, AND CABINETS**

GENERAL

RELATED DOCUMENTS

Drawings and general provisions of the Contract, including General and Supplementary Conditions and Division 1 Specification Sections, apply to this Section.

SUMMARY

This Section includes raceways, fittings, boxes, enclosures, and cabinets for electrical wiring.

- Raceways include the following:
 1. Rigid metal conduit
 2. Intermediate metal conduit
 3. Electrical metallic tubing (EMT)
 4. Liquidtight flexible conduit
 5. Rigid nonmetallic conduit
 6. Wireway
 7. Surface raceways
- Boxes, enclosures, and cabinets include the following:
 1. Device boxes
 2. Outlet boxes
 3. Pull and junction boxes
 4. Cabinets and hinged cover enclosures
- Related Sections: The following Sections contain requirements that relate to this Section:
 1. Section 16190 "Supporting Devices" for raceway and box supports.
 2. Section 16119 "Underground Ducts and Utility Structures."

SUBMITTALS

General: Submit the following according to the Conditions of the Contract and Division 1 Specification Sections.

Product data for surface raceway, wireway and fittings, floor boxes, hinged cover enclosures, and cabinets.

Shop drawings for nonstandard boxes, enclosures, and cabinets. Include layout drawings showing components and wiring.

QUALITY ASSURANCE

Comply with NFPA 70 "National Electrical Code" for components and installation.

Listing and Labeling: Provide products specified in this Section that are listed and labeled.

- The Terms "Listed and Labeled": As defined in the "National Electrical Code," Article 100.

**RACEWAY, BOXES, AND CABINETS
16100-1**

**FRONT ST PHASE 4 UG INFRASTRUCTURE UPGRADE (T2)
CITY OF GEORGETOWN**

- Listing and Labeling Agency Qualifications: A "Nationally Recognized Testing Laboratory" (NRTL) as defined in OSHA Regulation 1910.7.

Comply with NECA "Standard of Installation."

Coordinate layout and installation of raceway and boxes with other construction elements to ensure adequate headroom, working clearance, and access.

PRODUCTS

MANUFACTURERS

Available Manufacturers: Subject to compliance with requirements, Manufacturers offering products that may be incorporated into the Work include, but are not limited to, the following:

Metal Conduit and Tubing:

- Monogram Co., AFC.
- Alflex Corp.
- Allied Tube and Conduit, Grinnell Co.
- Anamet, Inc., Anaconda Metal Hose.
- Anixter Brothers, Inc.
- Carol Cable Co., Inc.
- Cole-Flex Corp.
- Flexcon, Inc., Coleman Cable Systems, Inc.
- Spiraduct, Inc.
- Triangle PWC, Inc.
- Wheatland Tube Co.

Nonmetallic Tubing and Conduit:

- Anamet, Inc., Anaconda Metal Hose.
- Arnco Corp.
- Breeze-Illinois, Inc.
- Can-Tex Industries, Harsco Corp.
- Carlon.
- Certainteed Corp, Pipe & Plastics Group.
- Cole-Flex Corp.
- Condux International, Electrical Products.
- Electri-Flex Co.
- George-Ingraham Corp.
- Hubbell, Inc., Raco, Inc.
- R&G Sloan Manufacturing Co., Inc.
- Spiraduct, Inc.
- Thomas & Betts Corp.

Conduit Bodies and Fittings:

- Scott Fetzer Company, Adalet-PLM.
- American Electric, Construction Materials Group.
- Emerson Electric Co., Appleton Electric Co.
- Carlon.

RACEWAY, BOXES, AND CABINETS

16100-2

**FRONT ST PHASE 4 UG INFRASTRUCTURE UPGRADE (T2)
CITY OF GEORGETOWN**

- Hubbell, Inc., Killark Electric Manufacturing Co.
- General Signal, O-Z/Gedney Unit.
- Spring City Electrical Manufacturing Co.

Wireway:

- Hoffman Engineering Co.
- Keystone/Rees, Inc.
- Square D Co.

Surface Metal Raceway:

- Airey-Thompson Co., Inc., A-T Power Systems.
- American Electric, Construction Materials Group.
- Butler Manufacturing Co., Walker Division.
- The Wiremold Co., Electrical Sales Division.

Surface Nonmetallic Raceway:

- Anixter Brothers, Inc.
- Butler Manufacturing Co., Walker Division.
- Hubbell, Inc., Wiring Device Division.
- JBC Enterprises, Inc., Enduro Fiberglass Systems.
- Panduit Corp.
- United Telecom, Premier Telecom Products, Inc.
- Thermotools Co.
- The Wiremold Co., Electrical Sales Division.

Boxes, Enclosures, and Cabinets:

- Scott Fetzer Company, Adalet-PLM.
- Butler Manufacturing Co., Walker Division.
- Cooper Industries, Midwest Electric.
- Electric Panelboard Co., Inc.
- Erickson Electrical Equipment Co.
- American Electric, FL Industries.
- Hoffman Engineering Co., Federal-Hoffman, Inc.
- Hubbell Inc., Killark Electric Manufacturing Co.
- General Signal, O-Z/Gedney.
- Oldcastle Infrastructure
- Parker Electrical Manufacturing Co.
- Racco, Inc., Hubbell Inc.
- Robroy Industries, Inc., Electrical Division.
- Spring City Electrical Manufacturing Co.
- Square D Co.
- Thomas & Betts Corp.
- Woodhead Industries, Inc., Daniel Woodhead Co.

METAL CONDUIT AND TUBING

Rigid Steel Conduit: ANSI C80.1.

FRONT ST PHASE 4 UG INFRASTRUCTURE UPGRADE (T2) CITY OF GEORGETOWN

Intermediate Metal Conduit: ANSI C80.6.

Electrical Metallic Tubing and Fittings: ANSI C80.3 with set-screw or compression-type fittings.

Liquidtight Flexible Metal Conduit: Flexible steel conduit with PVC jacket.

Fittings: NEMA FB 1, compatible with conduit/tubing materials.

NONMETALLIC CONDUIT AND TUBING

Rigid Nonmetallic Conduit (RNC): NEMA TC 2, Schedule 40 or 80 PVC.

PVC Conduit and Tubing Fittings: NEMA TC 3; match to conduit or conduit/tubing type and material.

OUTLET AND DEVICE BOXES

Sheet Metal Boxes: NEMA OS 1.

Cast Metal Boxes: NEMA FB 1, type FD, cast ferrous alloy box with gasketed cover.

Nonmetallic Boxes: NEMA OS 2.

FLOOR BOXES

Floor Box: Cast metal, fully adjustable, rectangular.

PULL AND JUNCTION BOXES

Small Sheet Metal Boxes: NEMA OS 1.

Cast Metal Boxes: NEMA FB 1, cast aluminum with gasketed cover.

EXECUTION

EXAMINATION

Examine surfaces to receive raceways, boxes, enclosures, and cabinets for compliance with installation tolerances and other conditions affecting performance of the raceway system. Do not proceed with installation until unsatisfactory conditions have been corrected.

WIRING METHODS

Outdoors: Use the following wiring methods:

- Exposed: Rigid metal conduit.
- Concealed: Rigid or intermediate metal conduit.
- Underground, Single Run: Rigid nonmetallic conduit.
- Underground, Grouped: Rigid nonmetallic conduit.
- Connection to Vibrating Equipment (including transformers and hydraulic, pneumatic, or electric solenoid or motor-driven equipment): Liquidtight flexible metal conduit.
- Boxes and Enclosures: NEMA Type 3R.

INSTALLATION

- Install raceways, boxes, enclosures, and cabinets as indicated, according to manufacturer's written instructions.

**FRONT ST PHASE 4 UG INFRASTRUCTURE UPGRADE (T2)
CITY OF GEORGETOWN**

- Install raceways level and square and at proper elevations.
- Complete raceway installation before starting cable installation.
- Use temporary closures to prevent foreign matter from entering raceway.
- Protect stub-ups from damage where conduits rise through pads. Arrange so curved portion of bends is not visible above the finished slab.
- Make bends and offsets so the inside diameter is not reduced. Unless otherwise indicated, keep the legs of a bend in the same plane and the straight legs of offsets parallel.
- Use raceway fittings compatible with raceway and suitable for use and location. For intermediate steel conduit, use threaded rigid steel conduit fittings, except as otherwise indicated.
- Run concealed raceways with a minimum of bends in the shortest practical distance except as otherwise indicated.
- Raceways Underneath Slabs: Install below compacted stone. All 90 degree bends shall be below compacted stone with conduit penetrations of slab fully vertical.
- Transition nonmetallic tubing to rigid steel conduit before rising above floor.
- Run parallel or banked raceways together, on common supports where practical.
- Make bends in parallel or banked runs from same center line to make bends parallel. Use factory elbows only where they can be installed parallel; otherwise, provide field bends for parallel raceways.
- Join raceways with fittings designed and approved for the purpose and make joints tight.
- Make raceway terminations tight. Use bonding bushings or wedges at connections subject to vibration. Use bonding jumpers where joints cannot be made tight.
- Tighten set screws of threadless fittings with suitable tool.
- Terminations: Where raceways are terminated with locknuts and bushings, align the raceway to enter squarely, and install the locknuts with dished part against the box. Where terminations cannot be made secure with one locknut, use two locknuts, one inside and one outside the box.
- Where terminating in threaded hubs, screw the raceway or fitting tight into the hub so the end bears against the wire protection shoulder. Where chase nipples are used, align the raceway so the coupling is square to the box, and tighten the chase nipple so no threads are exposed.
- Install pull cord in empty raceways. Use 200 pound test nylon cord.
- Raceways 2-Inch Trade Size and Smaller: In addition to the above requirements, install in maximum lengths of 150 feet (45 m) and with a maximum of two 90-deg bends or equivalent. Install pull or junction boxes where necessary to comply with these requirements.
- Install raceway sealing fittings according to the manufacturer's written instructions. Locate fittings at suitable, approved, accessible locations and fill them with UL-listed sealing compound. For concealed raceways, install each fitting in a flush steel box with a blank cover plate having a finish

**RACEWAY, BOXES, AND CABINETS
16100-5**

**FRONT ST PHASE 4 UG INFRASTRUCTURE UPGRADE (T2)
CITY OF GEORGETOWN**

similar to that of adjacent plates or surfaces. Install raceway sealing fittings at the following points and elsewhere as indicated:

- Where conduits enter or leave hazardous locations.
- Where conduits pass from warm locations to cold locations, such as the boundaries of refrigerated spaces and air-conditioned spaces.
- Where otherwise required by the NEC.
- **Stub-Up Connections:** Extend conduits through concrete pad with an adjustable top or coupling threaded inside for plugs, and set flush with the finished pad. Transition to nonmetallic conduit to ridged steel conduit before penetrating pad. Extend cables to equipment with rigid steel conduit. Where equipment connections are not made under this Contract, install screwdriver-operated threaded flush plugs flush with floor. Install grounding hubs for all conduit stub-ups.
- Do not install aluminum conduit embedded in or in contact with concrete.
- Provide grounding connections for raceway, boxes, and components as indicated and instructed by manufacturer. Tighten connectors and terminals, including screws and bolts, according to equipment manufacturer's published torque-tightening values for equipment connectors. Where manufacturer's torqueing requirements are not indicated, tighten connectors and terminals according to tightening torques specified in UL Standard 486A.

PROTECTION

Provide final protection and maintain conditions, in a manner acceptable to manufacturer and Installer, to ensure that coatings, finishes, and cabinets are without damage or deterioration at Substantial Completion.

Repair damage to galvanized finishes with zinc-rich paint recommended by manufacturer.

Repair damage to PVC or paint finishes with matching touch-up coating recommended by the manufacturer.

CLEANING

Upon completion of installation of system, including outlet fittings and devices, inspect exposed finish. Remove burrs, dirt, and construction debris and repair damaged finish, including chips, scratches, and abrasions.

(END OF SECTION)

**FRONT ST PHASE 4 UG INFRASTRUCTURE UPGRADE (T2)
CITY OF GEORGETOWN**

**SECTION 16119
UNDERGROUND DUCTS & UTILITY STRUCTURES**

GENERAL

RELATED DOCUMENTS

Drawings and general provisions of the Contract, including General and Supplementary Conditions and Division 1 Specification Sections, apply to this Section.

SUMMARY

This Section includes underground conduits and ducts, pull boxes, handholes, concrete-encased duct banks, and other underground utility structures.

Related Sections: The following Sections contain requirements that relate to this Section:

- Section 16050 Basic Electrical Materials and Methods for general requirements for excavation, backfill and related items for ducts, manholes, and handholes.
- Section 03300 "Cast-In-Place / Ready Mix Concrete" for cast-in-place concrete requirements.

DEFINITIONS

Duct: Electrical conduit and other raceway, either metallic or nonmetallic, used underground, embedded in earth or concrete.

SUBMITTALS

General: Submit the following according to Conditions of the Contract and Division 1 Specification Sections.

Product data for metal accessories for conduit and miscellaneous components.

QUALITY ASSURANCE

Comply with NFPA 70 "National Electric Code" and ANSI C2 "National Electrical Safety Code" for components and installation.

Listing and Labeling: Provide products specified in this Section that are listed and labeled.

- The Terms "Listed" and "Labeled". As defined in the "National Electrical Code," Article 100.
- Coordinate layout and installation of ducts with final arrangement of other utilities as determined in the field.

DELIVERY, STORAGE, AND HANDLING

Deliver ducts to site with ends capped. Store nonmetallic ducts with supports to prevent bending, warping, and deforming.

PRODUCTS

MANUFACTURERS

Available Manufacturers: Subject to compliance with requirements, manufacturers offering products that may be incorporated into the Work include, but are not limited to, the following:

FRONT ST PHASE 4 UG INFRASTRUCTURE UPGRADE (T2) CITY OF GEORGETOWN

- Nonmetallic Ducts:
 1. Arnco Corp.
 2. Breeze-Illinois, Inc.
 3. CANTEX, Inc.
 4. Carlon; Lamson & Sessions Company
 5. Pipe & Plastic Group; Certainteed Products Corp.
 6. Cole-Flex Co.
 7. Electri-Flex Co.
 8. Spiraduct, Inc.

CONDUIT AND DUCT

Rigid Steel Conduit: ANSI C80.1, galvanized.

Plastic Conduit for Direct Burial and Riser Applications: EPC-40-PVC UL 651 and NEMA TC 2.

Plastic Conduit for Concrete Encasement: DB-60-PVC UL 651 and NEMA TC 6 & 8.

Manufactured Bends: Not less than 36 inch (900 mm) radius.

High Density Polyethylene (HDPE) Electrical Conduit for Directional boring. Smoothwall, approved/listed for directional boring, minimum Schedule 80 UL 651 and NEMA TC 7.

ACCESSORIES

Duct Supports: Rigid PVC spacers selected to provide minimum duct spacings.

Duct Sealing Compound: Nonhardening, safe for human skin contact, not deleterious to cable insulation, workable at temperatures as low as 35 deg F (1 deg C), withstands temperature of 300 deg F (149 deg C) without slump, and adheres to clean surfaces of plastic ducts, metallic conduits, conduit coatings, concrete, masonry, lead, cable sheaths, cable jackets, insulation materials, and the common metals.

EXECUTION

APPLICATION

Direct buried or concrete encased PVC conduit.

EXAMINATION

Examine site to receive ducts for compliance with installation tolerances and other conditions affecting performance of the underground ducts. Do not proceed with installation until unsatisfactory conditions have been corrected.

EARTHWORK

Excavation and Backfill: Conform to Section 16050, "EXCAVATION", but do not use heavy-duty, hydraulic-operated compaction equipment.

Restore surface features at areas disturbed by excavation, and re-establish original grades except as otherwise indicated. Replace removed sod as soon as possible after backfilling is completed. Restore all areas disturbed by trenching, storing of dirt, cable laying, and other work. Restore vegetation and include necessary topsoiling, fertilizing, liming, seeding, sodding, sprigging, or mulching.

UNDERGROUND DUCTS & UTILITY STRUCTURES

16119-2

**FRONT ST PHASE 4 UG INFRASTRUCTURE UPGRADE (T2)
CITY OF GEORGETOWN**

Paving: Where cuts are made in any paving, the paving and subbase shall be restored to their original condition. South Carolina Department of Transportation (SCDOT) standards shall be followed wherever applicable.

Utilities: Where existing utilities are shown or noted on the Drawings to be altered or removed by others, or by a local utility company or municipality for installation of the new construction, give sufficient notice to applicable parties so that such alteration can be made.

CONDUIT & DUCT INSTALLATION

Install nonmetallic conduit and duct as indicated according to manufacturer's written instructions.

Depths to the top of conduits shall not be less than 24 inches for conduits with secondary and service cables and not less than 30 inches for conduits with primary cables. Conduits shall slope toward manholes or pull boxes and shall not have low points between ends.

Direct buried conduits shall be PVC schedule 40 or Schedule 80.

All underground concrete-encased conduits shall be Type DB encased in a 4,000 minimum psi concrete, to a minimum thickness of 3 inches from any conduit. Concrete encasement shall be reinforced with ½" steel rebar. The top of the encasement shall be a minimum of 21" below earth grade and a magnetically detectable tape (minimum width 1") is to be buried 6" below finished grade and following the centerline of the encasement. Conduits' outer edges within the encasement are to be spaced a minimum of 1" apart as shown on the drawings. All conduit segments are to be supplied with a nylon pull rope or ribbon of sufficient tensile strength to facilitate the installation of cables.

Rigid PVC interlocking spacers shall be used in concrete, selected to provide minimum conduit spacings and cover depths indicated while supporting conduits during concreting and backfilling; produced by the same manufacturer as the conduits.

Provisions shall be taken to prevent conduits from floating during concreting process, either by fastening spacers to trench bottom or by placing weights on entire conduit and spacer assembly. Ensure that conduits are adequately spaced to allow concrete to fill all voids between conduits.

All concrete-encased conduits shall be plugged during the concreting and backfilling processes. Duct plugs shall be manufactured from high impact plastic components and shall be corrosion proof. Duct plugs shall contain a durable elastic compressible gasket which will make it effective as a long term or temporary seal. They shall be removable and reusable. They shall meet or exceed the following mechanical requirements:

- a. Air Pressure 7.5 psi
- b. Water Head 15 ft.
- c. Pull Out 100 Kgf

Duct plugs used on spare conduits shall be equipped with a rope tie device on the back compression plate to allow the securing of a pull rope. This will allow excess rope slack to be stored within the conduit.

Curves and Bends: Use manufactured elbows for stub-ups at equipment and at building entrances. Use manufactured long sweep bends with a minimum radius of 36" both horizontally and vertically at other locations.

- Make joints in ducts and fittings watertight according to manufacturer's instructions. Stagger couplings so those of adjacent ducts do not lie in the same plane.

**FRONT ST PHASE 4 UG INFRASTRUCTURE UPGRADE (T2)
CITY OF GEORGETOWN**

CONNECTIONS TO EXISTING CONCRETE PADS

For duct bank connections to concrete pads, break an opening in the pad out to the dimensions required and preserve steel in pad. Cut the steel and extend into the duct bank envelope. Chip out the opening in the pad to form a key for the duct bank envelope.

CONNECTIONS TO EXISTING DUCTS

Where connections to existing duct banks are indicated, excavate the banks to the maximum depth necessary. Cut off the banks and remove loose concrete from the conduits before new concrete-encased ducts are installed. Provide a reinforced concrete collar, poured monolithically with the new duct bank, to take the shear at the joint of the duct banks.

DIRECTIONAL BORING

HDPE conduits must be installed below the frostline and as specified herein.

FIELD QUALITY CONTROL

Testing: Demonstrate capability and compliance with requirements upon completion of installation of underground duct and utility structures.

Duct Integrity: Rod ducts with a mandrel ¼ inch (6 mm) smaller in diameter than internal diameter of ducts. Where rodding indicates obstructions in ducts, remove the obstructions and retest.

Correct installations where possible, and retest to demonstrate compliance. Otherwise, remove and replace defective products and retest.

CLEANING

Pull brush through full length of ducts. Use round bristle brush with a diameter ½ inch (12 mm) greater than internal diameter of duct.

(END OF SECTION)

**FRONT ST PHASE 4 UG INFRASTRUCTURE UPGRADE (T2)
CITY OF GEORGETOWN**

**SECTION 16120
WIRES AND CABLES**

GENERAL

RELATED DOCUMENTS

Drawings and general provisions of the Contract, including General and Supplementary Conditions and Division 1 Specification Sections, apply to this Section.

SUMMARY

This Section includes wires and cables and associated splices, connectors, and terminations for wiring systems rated 600 volts and less.

Related Sections: The following Sections contain requirements that relate to this Section:

- Division 16 Section 16124 "Medium-Voltage Cables."
- Division 16 Section 16190 "Supporting Devices" for supports and anchors for fastening cable directly to building finishes.
- Division 16 Section 16195 "Electrical Identification" for insulation color coding and wire and cable markers.

SUBMITTALS

General: Submit the following according to the Conditions of the Contract and Division 1 Specification Sections.

Field test reports indicating and interpreting test results relative to compliance with performance requirements of testing standard.

Submit manufacturer's catalog descriptions of each wire, cable, or conductor for engineer's approval before ordering cable.

QUALITY ASSURANCE

Comply with NFPA 70 "National Electrical Code" for components and installation.

Listing and Labeling: Provide products specified in this Section that are listed and labeled.

The Terms "Listed and Labeled": As defined in the "National Electrical Code," Article 100.

SEQUENCING AND SCHEDULING

Coordination: Coordinate layout and installation of cable with other installations.

Revise locations and elevations from those indicated as required to suit field conditions and as approved by the Engineer.

DELIVERY, STORAGE, AND HANDLING

Deliver wire and cable according to NEMA WC-26.

**FRONT ST PHASE 4 UG INFRASTRUCTURE UPGRADE (T2)
CITY OF GEORGETOWN**

PRODUCTS

MANUFACTURERS

Available Manufacturers: Subject to compliance with requirements, Manufacturers offering products that may be incorporated into the Work include, but are not limited to, the following:

Wires and Cables:

- American Wire Group
- Houston Wire & Cable
- Prysmian Group
- Southwire Co.
- Okonite Co.

Connectors for Wires and Cables:

- AFC, Monogram Co.
- AMP, Inc.
- Anderson, Square D Co.
- Electrical Products Division, 3M Co.
- O-Z/Gedney Unit, General Signal
- Thomas & Betts
- Burndy

LOW VOLTAGE INSULATED CONDUCTORS AND CABLES

Insulated conductors must be rated 600 volts and conform to the requirements of NFPA 70, including listing requirements, or in accordance with NEMA WC 70. Service entrance conductors must conform to UL 854, type USE.

CONNECTORS AND SPLICES

UL-listed factory-fabricated wiring connectors of size, ampacity rating, material, and type and class for application and for service indicated. Select to comply with Project's installation requirements and as specified in the below "Applications" Article. All control circuits are to be terminated with "ring tongue" insulated compression lugs.

Low voltage cables in manholes or pull boxes shall be terminated with compression NEMA spade terminals with insulated sleeves. Connectors shall be submersible insulated multi-port bus, Thomas & Betts Homac Flood-Seal, 125 Series or 175 Series as noted on the drawings, or acceptable equal.

EXECUTION

EXAMINATION

Inspect each cable reel for correct storage positions, signs of physical damage, and broken end seals prior to installation. If end seal is broken, remove moisture from cable prior to installation in accordance with the cable manufacturer's recommendations.

Examine raceways to receive wires and cables for compliance with installation tolerances and other conditions. Do not proceed with installation until unsatisfactory conditions have been corrected.

APPLICATIONS

Primary 12.47 kV distribution: Refer to Medium Voltage Cables Section 16124

FRONT ST PHASE 4 UG INFRASTRUCTURE UPGRADE (T2) CITY OF GEORGETOWN

Secondary and Services: Refer to above Connectors and Splices section above.

INSTALLATION

- Install wires and cables as indicated, according to manufacturer's written instructions and the NECA "Standard of Installation."
- Pull cables into raceway simultaneously where more than one is being installed in same raceway.
- Use pulling compound or lubricant where necessary; compound used must not deteriorate cable or insulation.
- Use pulling means, including fish tape, cable, rope, and basket-weave wire/cable grips that will not damage cables or raceway.
- Install exposed cable, parallel and perpendicular to surfaces or exposed structural members, and follow surface contours where possible.
- Cable Splices: Splices are not allowed unless noted on drawings.
- Tighten connectors and terminals, including screws and bolts, according to equipment manufacturer's published torque-tightening values for equipment connectors.
- Where manufacturer's torquing requirements are not indicated, tighten connectors and terminals according to tightening torques specified in UL Standard 486A.

FIELD QUALITY CONTROL

TESTING

Secondary or service low-voltage cable, complete with splices, shall be tested for insulation resistance after the cables are installed, in their final configuration, ready for connection to the equipment, and prior to energization. The test voltage shall be 500 volts dc, applied for one minute between each conductor and ground and between all possible combinations of conductors in the same trench, duct, or cable, with other conductors in the same trench, duct, or conduit. The minimum value of insulation shall be:

$$R \text{ in megohms} = (\text{rated voltage in kV} + 1) \times 1000 \div (\text{length of cable in feet})$$

Each cable failing this test shall be repaired or replaced. The repaired cable shall then be retested until failures have been eliminated.

PROCEDURES

Perform each visual and mechanical inspection and electrical test stated in NETA Standard ATS, Section 7.3.2. Certify compliance with test parameters.

CORRECTIONS

Correct malfunctioning products at site, where possible, and retest to demonstrate compliance; otherwise, remove and replace with new units, and retest.

(END OF SECTION)

**FRONT ST PHASE 4 UG INFRASTRUCTURE UPGRADE (T2)
CITY OF GEORGETOWN**

**SECTION 16124
MEDIUM VOLTAGE CABLES**

GENERAL

RELATED DOCUMENTS

Drawings and general provisions of the Contract, including General and Supplementary Conditions and Division 1 Specification Sections, apply to this Section.

SUMMARY

This Section includes cables and related splices, terminations, and accessories for electrical distribution systems rated above 2,000 volts.

This Section also includes medium voltage cable testing and acceptance requirements.

Related Sections: The following Sections contain requirements that relate to this Section:

- Division 16 Section 16190 "Supporting Devices" for cable and termination supports.
- Division 16 Section 16195 "Electrical Identification" for cable markers.

SUBMITTALS

General: Submit the following according to the Conditions of the Contract and Division 1 Specification Sections.

- Product data for cables and cable accessories, including splices and terminations including warranty statement.
- Product certificate signed by manufacturer that its products comply with the specified requirements.
- Product Test Reports: Certified reports of manufacturers' design and production tests indicating compliance of cable and accessories with referenced standards.
- Field test reports indicating and interpreting test results relative to compliance with performance requirements specified. Include certified copies of field test records.
- Maintenance Data: For cables and accessories, to be included in the "Project Manual" specified in Division 1.
- In-Service Data: Include periodic tests of cables in service.
- Provide certification of compliance with the Engineer's design requirements for each directional bore, including: HDPE conduit size and type, bend radius, elevation changes, and vertical and horizontal path deviations. Record location and depth of all directional-bore installed HDPE conduits using Global Positioning System (GPS) recording means with "resource grade" accuracy

QUALITY ASSURANCE

Installer Qualifications: Engage an experienced and certified cable splicer to install, splice, and terminate medium voltage cables.

Manufacturer Qualifications: Firm experienced in manufacturing medium voltage cable and accessories similar to those indicated for this project, with a record of successful in-service performance.

Comply with NFPA 70 "National Electric Code" for components and installation.

Listing and Labeling: Provide products specified in this Section that are listed and labeled.

**MEDIUM VOLTAGE CABLES
16124-1**

**FRONT ST PHASE 4 UG INFRASTRUCTURE UPGRADE (T2)
CITY OF GEORGETOWN**

The terms "listed and labeled": As defined in the "National Electrical Code", Article 100.

Single-Source Responsibility: All medium voltage cable shall be the product of a single manufacturer.

DELIVERY, STORAGE & HANDLING

CABLE REELS

Deliver medium voltage cables on factory reels conforming to NEMA WC26.

The Contractor shall inspect each reel of cable upon delivery. At this time, the cable protective covering shall be inspected for damage. Any damage found shall be reported to the Engineer without delay.

Loading and unloading shall be accomplished so that the lifting equipment does not contact the cable protective wrap or the cable surface. If a crane is used, the either a cradle supporting the reel flanges or a shaft through the arbor hole shall be used. If a fork lift is used, the forks shall lift the reel at 90 degrees to the reel flanges and the fork shall be long enough to make complete lifting contact with the flanges. Under no circumstances shall the forks contact the cable surface or the protective wrap. If an inclined ramp is used, the ramp shall be at the bottom of the ramp shall be accomplished by using the reel flanges and not the surface of the cable.

Under no circumstances shall the reels be dropped from any vehicle or equipment onto the ground or any other surface.

Reels shall be stored, standing on the flange edges, on a rigid surface to ensure that the flanges do not sink into the earth and do not allow the weight of the reel and cable to rest on the cable surface. Reels shall not be stored resting on the flat side of the flanges.

Cable shall not be stored in any area where it may be contacted by vehicles, equipment, falling objects, chemicals, petroleum, or other harmful materials, or where it may be damaged by high heat.

When the cable is to be installed at ambient temperatures 32 F (0 C), it shall be stored in a heated area at least 24 hours prior to installation. The cable shall not be installed at temperatures below 14 F (-10 C).

Whenever cable reels are moved by rolling, roll in the correct direction to avoid loosening the cable on the reel. Clear the rolling area of objects which could contact or possibly damage the cable or the protective wrap.

CABLE END SEALING

All cable ends shall be sealed when in storage or when installed and temporarily not terminated.

Procedure: The cable end shall be cleanly and squarely cut off. To the cable end apply a 3 ¼ inch square section on vinyl plastic seal over the exposed tape shall be applied lengthwise over the end of the cable first, and then wrapped tightly over the length of the cable for 3 inches to completely cover the seal material. The wrapping tape shall be overlapped by at least half the tape width.

The vinyl plastic seal shall be Aqua Seal or equivalent.

PRODUCTS

MANUFACTURERS

Manufacturers: Subject to compliance with requirements, provide products by one of the following:

**MEDIUM VOLTAGE CABLES
16124-2**

**FRONT ST PHASE 4 UG INFRASTRUCTURE UPGRADE (T2)
CITY OF GEORGETOWN**

- Power Cable:
 1. Cablec Corp.
 2. Hubbell Inc., The Kerite Co.
 3. The Okonite Co.
 4. Power Cable Division, Pirelli Cable Corp.
- Cable Splicing and Terminating Products and Accessories:
 1. Cooper Power Systems, Inc., RTE Components
 2. Elastimold
 3. Raychem Electrical Products Division
 4. 3M Electrical Products Division
- Separable Insulated Connector Components and Accessories:
 1. Cooper Power Systems, Inc., RTE Components
 2. Elastimold
 3. Joslyn Manufacturing Co.

CABLE

Type: MV105, Primary UD EPR cable

Conductor: Aluminum phase conductor, stranded

Conductor Stranding: Filled with water swellable agent meeting or exceeding ICEA T-31-610 water penetration resistance and ANSI/NEMA class A connectorability requirements.

Rated System Voltage Class: for 12.47 kV application: 15 kV, Primary UD

Insulation: Discharge resistant ethylene propylene rubber (EPR) conforming to ANSI/ICEA S-94-649, UL 1072, RUS 1728F-U1 and AEIC CS8. Insulation shall be of a color contrasting with the extruded semi-conducting shield. Insulation rating shall equal or exceed 100 percent of the rated system voltage class. The cable shall be heat, moisture, ozone and corona resistant, for use at 105 C conductor temperature. The insulation compound shall be compounded by the manufacturer in its own facility.

Concentric Neutral: Bare copper wires.

Jacket: Insulating linear low density polyethylene applied over the insulation shield. The jacket shall be oil, acid, alkali and sunlight resistant and meet or exceed NEMA WC74 and UL 1072.

Standards: The cable shall meet or exceed the following standards: ANSI/ICEA S-94-649, UL 1072, RUS 1728F-U1 and AEIC CS8

SPLICE KITS

Connectors: IEEE 404, compression type, as recommended by cable or splicing kit manufacturer for the application.

Splicing Products: As recommended in writing by the splicing kit manufacturer for the specific sizes, ratings, and configurations of cable conductors and splices specified. Include all components required for complete splice, with detailed instructions.

Heat-shrink splicing kit of uniform cross-section polymeric construction with outer heat-shrink jacket.

Premolded, cold-shrink rubber, inline splicing kit.

**FRONT ST PHASE 4 UG INFRASTRUCTURE UPGRADE (T2)
CITY OF GEORGETOWN**

LOAD BREAK ELBOW CONNECTORS

The molded rubber 15 kV class, fused, load break, elbow cable connector termination kits shall be designed and manufactured for terminating the specified power cables. Contractor shall coordinate with manufacturers' data to determine exact diameters. Insulation class shall be equivalent to that of the cable.

Elbow connectors shall meet ANSI and IEEE standards C37.40, C37.41, C37.47, and 386-2006. Elbow connectors shall be fully shielded and insulated capable of full range current limiting fuse protection. Molded materials shall be of high quality peroxide-cured insulating and semi-conducting EPDM rubber. Standard features shall include a copper probe adapter, copper top connector, copper load break probe with an ablative arc-follower tip and stainless steel reinforced pulling eye. Feed-thru elbow connectors shall be provided where indicated on the drawings.

CABLE TERMINATIONS

The terminations shall be Class 1 for shielded cable, meeting the latest release of IEEE Standard 48, and suitable for use outdoors on underground circuit dip poles. The terminations shall be of the molded elastomer, prestretched elastomer, or heat-shrinkable elastomer type, with multiple molded nontracking skirt modules, and compression-type connector. Terminations for shielded cables shall include a shield ground strap.

Terminations, must be provided with mounting brackets suitable for the intended installation and with grounding provisions for the cable shielding. Terminations must be provided in a kit, including: skirts, stress control terminator, ground clamp, connectors, lugs, and complete instructions for assembly and installation. Terminations must be the product of one manufacturer, suitable for the type, diameter, insulation class and level, and materials of the cable terminated.

SOURCE QUALITY CONTROL

Test and inspect cables according to NEMA WC74 before shipping.

MEDIUM VOLTAGE CABLE WARRANTY

The cable manufacturer shall warrant each reel of cable to be free from defects in material, design and workmanship to provide reliable performance for a twenty-five (25) year life.

The warranty assumes the cable is installed, spliced, terminated and maintained in accordance with manufacturer's recommendations.

Prior to termination or splicing of cable, the contractor responsible for same shall submit qualifications of his personnel responsible for this work and their qualification to do same. Upon approval by the engineer in writing, contractor may proceed with this portion of the work.

Defective cable shall be replaced at no cost to the owner.

- When the manufacturer and the owner mutually determine a portion of or all the cable is defective, the cable manufacturer shall furnish replacement of said cable without charge.
- The replacement cable shall comply with these requirements and be delivered to the original delivery point free of any charge to the owner or the state of North Carolina.

Contractor shall state on his bid form the name of the cable manufacturer he intends to supply. Failure to do this places the contractor at risk of rejection of his bid.

**FRONT ST PHASE 4 UG INFRASTRUCTURE UPGRADE (T2)
CITY OF GEORGETOWN**

Cable shop drawings shall include said described warranty from the cable manufacturer properly signed, and having the manufacturer's corporate seal affixed thereto.

EXECUTION

EXAMINATION

Examine raceways to receive medium voltage cables for compliance with installation tolerances and other conditions affecting performance of the cable. Do not proceed with installation until unsatisfactory conditions have been corrected.

INSTALLATION

Install medium voltage cable as indicated, according to manufacturer's written instructions and IEEE 576.

Pull cables simultaneously where more than one cable is indicated in same raceway. Use NRTL-listed and manufacturer-approved pulling compound or lubricant where necessary. Do not exceed manufacturer's recommended maximum pulling tensions and sidewall pressure values.

Use pulling means including fish tape cable, rope, and basket-weave wire/cable grips that will not damage cables or raceways. Do not use rope hitches for pulling attachment to cable.

In manholes, handholes, pull boxes, junction boxes, and cable vaults, train cables around walls by the longest route from entry to exit and support cables at intervals adequate to prevent sag.

Install splices at pull points and elsewhere as indicated using standard kit. Conform to kit manufacturer's written instructions.

Install terminations at ends of cables and seal multiconductor cable ends with standard kits. Conform to manufacturer's written instructions. Comply with classes of terminations indicated.

GROUNDING

Ground shields of shielded cable at terminations, splices, and separable insulated connectors. Ground metal bodies of terminators, splices, cable and separable insulated connector fittings, and hardware according to manufacturer's written instructions.

IDENTIFICATION

Identify cable in accordance with Section 16195 "Electrical Identification".

FIELD QUALITY CONTROL

Testing: Upon installation of medium voltage cable and before electrical circuitry has been energized, demonstrate product capability and compliance with requirements.

Procedures: Perform each visual and mechanical inspection and electrical test stated in NETA Standard ATS, Section 7.3.3. Certify compliance with test parameters.

Correct malfunctioning units at site, where possible, and retest to demonstrate compliance, otherwise, remove and replace with new units and retest.

**FRONT ST PHASE 4 UG INFRASTRUCTURE UPGRADE (T2)
CITY OF GEORGETOWN**

PROTECTION

Provide final protection and maintain conditions in a manner acceptable to manufacturer and installer, to prevent entrance of moisture into the cable and ensure that medium voltage cable is without damage or deterioration at Substantial Completion.

TESTING AND ACCEPTANCE

After installation, prior to connection to an existing system, and before the operating test, the medium-voltage cable system shall be given a high potential test. Direct-current voltage shall be applied on each phase conductor of the system by connecting conductors at one terminal and connecting grounds or metallic shieldings or sheaths of the cable at the other terminal for each test. Prior to the test, the cables shall be isolated by opening applicable protective devices and disconnecting equipment. The method, voltage, length of time, and other characteristics of the test for initial installation shall be in accordance with IEEE 400.1 for the particular type of cable installed, and shall not exceed the recommendations of IEEE 404 for cable joints unless the cable and accessory manufacturers indicate higher voltages are acceptable for testing. Should any cable fail due to a weakness of conductor insulation or due to defects or injuries incidental to the installation or because of improper installation of cable, cable joints, terminations, or other connections, the Contractor shall make necessary repairs or replace cables as directed. Repaired or replaced cables shall be retested.

Test work method and data sheet, including test date, time, and voltages shall be submitted to and approved by the Engineer prior to test voltage being applied to cables.

If new cable is spliced into existing cable, the new cable should be tested as specified prior to splice. After completing the splice, the completed connection shall be tested at the system operating voltage.

(END OF SECTION)

**FRONT ST PHASE 4 UG INFRASTRUCTURE UPGRADE (T2)
CITY OF GEORGETOWN**

**SECTION 16190
SUPPORTING DEVICES**

GENERAL

RELATED DOCUMENTS

Drawings and general provisions of Contract, including General and Supplementary Conditions and Division 1 Specification Sections, apply to this Section.

Requirements of the following Division 16 Sections apply to this section:

- Division 16 Section 16010 "Basic Electrical Requirements."
- Division 16 Section 16050 "Basic Electrical Materials and Methods."

SUMMARY

This Section includes secure support from the building structure for electrical items by means of hangers, supports, anchors, sleeves, inserts, seals, and associated fastenings.

Related Sections: The following Sections contains requirements that relate to this Section:

- Refer to other Division 16 sections for additional specific support requirements that may be applicable to specific items.

SUBMITTALS

General: Submit the following in accordance with General Conditions.

Product data for each type of product specified.

Shop drawings indicating details of fabricated products and materials.

QUALITY ASSURANCE

Electrical Component Standard: Components and installation shall comply with NFPA 70 "National Electrical Code."

Electrical components shall be listed and labeled by UL, ETL, CSA, or other approved, nationally recognized testing and listing agency that provides third-party certification follow-up services.

PRODUCTS

MANUFACTURERS

Available Manufacturers: Subject to compliance with requirements, Manufacturers offering products that may be incorporated into the Work include, but are not limited to, the following:

- Slotted Metal Angle and U-Channel Systems:
 1. Allied Tube & Conduit
 2. American Electric
 3. B-Line Systems, Inc.
 4. Cinch Clamp Co., Inc.
 5. GS Metals Corp.
 6. Haydon Corp.

**SUPPORTING DEVICES
16190-1**

**FRONT ST PHASE 4 UG INFRASTRUCTURE UPGRADE (T2)
CITY OF GEORGETOWN**

7. Kin-Line, Inc.
 8. Unistrut Diversified Products
- Conduit Sealing Bushings:
 1. Bridgeport Fittings, Inc.
 2. Cooper Industries, Inc.
 3. Elliott Electric Mfg. Corp.
 4. GS Metals Corp.
 5. Killark Electric Mfg. Co.
 6. Madison Equipment Co.
 7. L.E. Mason Co.
 8. O-Z/Gedney
 9. Producto Electric Corp.
 10. Raco, Inc.
 11. Red Seal Electric Corp.
 12. Spring City Electrical Mfg. Co.
 13. Thomas & Betts Corp.

COATINGS

Coating: Supports, support hardware, and fasteners shall be protected with zinc coating or with treatment of equivalent corrosion resistance using approved alternative treatment, finish, or inherent material characteristic. Products for use outdoors shall be hot-dip galvanized.

MANUFACTURED SUPPORTING DEVICES

Raceway Supports: Riser clamps, conduit straps, threaded C-clamps with retainers, and spring steel clamps.

Fasteners: Types, materials, and construction features as follows:

- Expansion Anchors: Carbon steel wedge or sleeve type.
- Toggle Bolts: All steel springhead type.
- Powder-Driven Threaded Studs: Heat-treated steel, designed specifically for the intended service.

Conduit Sealing Bushings: Factory-fabricated watertight conduit sealing bushing assemblies suitable for sealing around conduit, or tubing passing through concrete floors and walls. Construct seals with steel sleeve, malleable iron body, neoprene sealing grommets or rings, metal pressure rings, pressure clamps, and cap screws.

Cable Supports for Vertical Conduit: Factory-fabricated assembly consisting of threaded body and insulating wedging plug for nonarmored electrical cables in riser conduits. Provide plugs with number and size of cable gripping holes as required to suit individual risers. Construct body of malleable-iron casting with hot-dip galvanized finish.

U-Channel Systems: 16-gage steel channels, with 9/16-inch-diameter holes, at a minimum of 8 inches on center, in top surface. Provide fittings and accessories that mate and match with U-channel and are of the same manufacture.

FABRICATED SUPPORTING DEVICES

General: Shop- or field-fabricated supports or manufactured supports assembled from U-channel components.

SUPPORTING DEVICES

16190-2

**FRONT ST PHASE 4 UG INFRASTRUCTURE UPGRADE (T2)
CITY OF GEORGETOWN**

Steel Brackets: Fabricated of angles, channels, and other standard structural shapes. Connect with welds and machine bolts to form rigid supports.

EXECUTION

INSTALLATION

Install supporting devices to fasten electrical components securely and permanently in accordance with NEC requirements.

Raceway Supports: Comply with the NEC and the following requirements:

- Conform to manufacturer's recommendations for selection and installation of supports.

Strength of each support shall be adequate to carry present and future load multiplied by a safety factor of at least four. Where this determination results in a safety allowance of less than 200 lbs, provide additional strength until there is a minimum of 200 lbs safety allowance in the strength of each support.

- Support individual horizontal raceways by separate pipe hangers. Use spring steel fasteners that are specifically designed for supporting single conduits or tubing.
- Space supports for raceway in accordance with NEC.
- Conduit Seals: Install seals for conduit penetrations of slabs on grade and exterior walls below grade and where indicated. Tighten sleeve seal screws until sealing grommets have expanded to form watertight seal.

(END OF SECTION)

**FRONT ST PHASE 4 UG INFRASTRUCTURE UPGRADE (T2)
CITY OF GEORGETOWN**

**SECTION 16195
ELECTRICAL IDENTIFICATION**

GENERAL

RELATED DOCUMENTS

Drawings and general provisions of Contract, including General and Supplementary Conditions and Division 1 Specification Sections, apply to this Section.

Requirements of the following Division 16 Sections apply to this section:

- Division 16 Section 16010 "Basic Electrical Requirements."
- Division 16 Section 16050 "Basic Electrical Materials and Methods."

SUMMARY

This Section includes identification of electrical materials, equipment, and installations. It includes requirements for electrical identification components including but not limited to the following:

- Buried electrical line warnings.
- Identification labeling for raceways, cables, and conductors.
- Operational instruction signs.
- Warning and caution signs.
- Equipment labels and signs.

Related Sections: The following Sections contain requirements that relate to this Section:

- Division 16 Section 16120 "Wires and Cables" for requirements for color coding of cables for phase identification.

Refer to other Division 16 sections for additional specific electrical identification associated with specific items.

SUBMITTALS

General: Submit the following in accordance with General Conditions.

Product Data for each type of product specified.

Schedule of identification nomenclature to be used for identification signs and labels.

Samples of each color, lettering style, and other graphic representation required for identification materials; samples of labels and signs.

Cable schedule for inclusion in Project Maintenance Manual.

Proof copy of one line diagram sign for approval before production.

QUALITY ASSURANCE

Electrical Component Standard: Components and installation shall comply with NFPA 70 "National Electrical Code."

ANSI Compliance: Comply with requirements of ANSI Standard A13.1, "Scheme for the Identification of Piping Systems," with regard to type and size of lettering for raceway and cable labels.

**ELECTRICAL IDENTIFICATION
16195-1**

FRONT ST PHASE 4 UG INFRASTRUCTURE UPGRADE (T2) CITY OF GEORGETOWN

PRODUCTS

MANUFACTURERS

Available Manufacturers: Subject to compliance with requirements, Manufacturers offering products that may be incorporated into the Work include, but are not limited to, the following:

- American Labelmark Co.
- Calpico, Inc.
- Cole-Flex Corp.
- Emed Co., Inc.
- George-Ingraham Corp.
- Ideal Industries, Inc.
- Kraftbilt
- LEM Products, Inc.
- Markal Corp.
- National Band and Tag Co.
- Panduit Corp.
- Radar Engineers Div., EPIC Corp.
- Seton Name Plate Co.
- Standard Signs, Inc.
- W.H.Brady, Co.

ELECTRICAL IDENTIFICATION PRODUCTS

Underground Line Marking Tape: Permanent, bright-colored, continuous-printed, plastic tape compounded for direct-burial service not less than 6 inches wide by 4 mils thick. Printed legend indicative of general type of underground line below and as indicated on the drawings.

Brass or Aluminum Tags: Metal tags with stamped legend, punched for fastener. Dimensions: 2 inches by 2 inches by 19 gage.

Cable Ties: Fungus-inert, self-extinguishing, one-piece, self-locking nylon cable ties, 0.18-inch minimum width, 50-lb minimum tensile strength, and suitable for a temperature range from minus 50 deg F to 350 deg F. Provide ties in specified colors when used for color coding.

Heat Shrink Sleeves: Premanufactured heat shrinkable sleeves installed at each cable end, yellow or orange color with indelible marking.

EXECUTION

INSTALLATION

Identify Junction, Pull, and Connection Boxes: Code-required caution sign for boxes shall be pressure-sensitive, self-adhesive label indicating system voltage in black, preprinted on orange background. Install on outside of box cover. Also label box covers with identity of contained circuits. Use pressure-sensitive plastic labels at exposed locations and similar labels or plasticized card stock tags at concealed boxes.

Underground Electrical Line Identification: During trench backfilling, for exterior underground power, signal, and communications lines, install continuous underground plastic line marker, located directly above line at 6 to 8 inches below finished grade. Where multiple lines installed in a common trench or

ELECTRICAL IDENTIFICATION

16195-2

**FRONT ST PHASE 4 UG INFRASTRUCTURE UPGRADE (T2)
CITY OF GEORGETOWN**

concrete envelope, do not exceed an overall width of 16 inches; install a single line marker. Install line marker for all underground cable and wiring, both direct-buried and in raceway.

Cable Color Coding:

Phase Identification: Apply colored, pressure-sensitive plastic tape in half-lapped turns for a distance of 6 inches from terminal points and in boxes where splices or taps are made. Apply the last two laps of tape with no tension to prevent possible unwinding. Use 1-inch-wide tape in colors as specified. Do not obliterate cable identification markings by taping. Tape locations may be adjusted slightly to prevent such obliteration. Tape colors are to be as shown on drawing E3011 Miscellaneous Details.

Power Circuit Identification: Securely fasten identifying metal tags or aluminum wraparound marker bands to cables, feeders, and power circuits in pull boxes, manholes, and transformer enclosures with 1/4-inch steel letter and number stamps with legend to correspond with designations on Drawings. If metal tags are provided, attach them with approximately 55-lb test monofilament line or one-piece self-locking nylon cable ties.

Tag or label cables as follows at the conduit entry:

- Primary and Secondary Cables – manhole, pull box, or transformer number
- Service Cables – service address

(END OF SECTION)

**FRONT ST PHASE 4 UG INFRASTRUCTURE UPGRADE (T2)
CITY OF GEORGETOWN**

**SECTION 16320
PAD MOUNTED TRANSFORMERS**

GENERAL

RELATED DOCUMENTS

Drawings and general provisions of the Contract, including the General and Supplementary Conditions and Division 1 Specifications Sections, apply to this Section.

SUMMARY

This section describes the setting and installation of the Owner supplied pad mounted transformers. The use of the term "pad mounted transformer" describes all transformers to be installed with medium voltage windings on the primary and low voltage windings on the secondary.

Related Sections: The following Section contains requirements that relate to this Section.

- Division 2 Section 02110: "Site Preservation"
- Division 3 Section 03300: Cast in Place / Ready Mix Concrete for equipment pads.
- Division 16 Section 16124: "Medium Voltage Cables"

QUALITY ASSURANCE

Comply with NFPA 70, "National Electrical Code".

EXECUTION

INSTALLATION

The Contractor shall set and anchor all owner supplied transformers as indicated on the drawings.

The Contractor shall make all medium voltage, low voltage power, neutral, and ground connections necessary for proper operation of each pad mounted transformer. This shall include the installation of all necessary underground ducts and raceways

Contractor shall install transformers and accessory items according to manufacturer's written installation instructions and the following specifications.

IDENTIFICATION

Identify field-installed wiring and components and provide warning signs according to Division 16 Section "Electrical Identification".

Transformer labels: Stencil the transformer number and primary phase in durable, long lasting paint on each new pad-mounted transformer and existing pad-mounted transformer. Three-phase pad-mounted transformers should be listed as ØABC.

GROUNDING

Connections: Ground transformers to grounding system as indicated on the drawings and in Division 16 "Grounding".

CONNECTIONS

Install medium voltage, low voltage, neutral and ground connections.

**PAD MOUNTED TRANSFORMERS
16320-1**

**FRONT ST PHASE 4 UG INFRASTRUCTURE UPGRADE (T2)
CITY OF GEORGETOWN**

Tighten all electrical connectors and terminals according to manufacturer's published torque-tightening values. Where these values are not indicated, use those specified in UL 486A and UL 486B.

CLEANING

Inspect exterior of installed transformers. Remove paint splatters and other spots, dirt, and debris and thoroughly clean finish to restore a new appearance. Touch up scratches and mars of finish to match original finish.

Ensure transformer enclosure open and close properly with no binding or excessive force required. Ensure all enclosure safety locks and anti-tamper devices are working properly.

PROTECTION

Protect transformer finish and components during construction work by covering with tarpaulins or other appropriate cover.

(END OF SECTION)

**FRONT ST PHASE 4 UG INFRASTRUCTURE UPGRADE (T2)
CITY OF GEORGETOWN**

**SECTION 16452
GROUNDING**

GENERAL

RELATED DOCUMENTS

Drawings and general provisions of Contract, including General and Supplementary Conditions and Division 1 Specification Sections, apply to this Section.

Requirements of the following Division 16 Sections apply to this Section:

- Division 16 Section 16010 "Basic Electrical Requirements."
- Division 16 Section 16050 "Basic Electrical Materials and Methods."

SUMMARY

This Section includes solid grounding of electrical systems and equipment. It includes basic requirements for grounding for protection of life, equipment, circuits, and systems. Grounding requirements specified in this Section may be supplemented in other sections of these Specifications.

SUBMITTALS

General: Submit the following in accordance with General Conditions.

Product data for ground rods, connectors and connection materials, and grounding fittings.

Report of field tests and observations certified by the testing organization.

QUALITY ASSURANCE

Listing and Labeling: Provide products specified in this Section that are listed and labeled. The terms "listed" and "labeled" shall be defined as they are in the National Electrical Code, Article 100.

Listing and Labeling Agency Qualifications: A "Nationally Recognized Testing Laboratory" (NRTL) as defined in OSHA Regulation 1910.7.

Field-Testing Organization Qualifications: To qualify for acceptance, the independent testing organization must demonstrate, based on evaluation of organization-submitted criteria conforming to ASTM E 699, that it has the experience and capability to conduct satisfactorily the testing indicated.

Electrical Component Standard: Components and installation shall comply with NFPA 70, "National Electrical Code" (NEC).

PRODUCTS

MANUFACTURERS

Available Manufacturers: Subject to compliance with requirements, manufacturers offering products that may be incorporated in the Work include, but are not limited to, the following:

- Anixter Bros., Inc.
- Bashlin Industries, Inc.
- Buckingham Mfg. Co.
- A.B. Chance Co.
- Dossert Corp.

**FRONT ST PHASE 4 UG INFRASTRUCTURE UPGRADE (T2)
CITY OF GEORGETOWN**

- Engineered Products Co.
- Erico Products, Inc.
- Galvan Industries, Inc.
- GB Electrical, Inc.
- General Machine Products Co., Inc.
- Hastings Fiber Glass Products, Inc.
- Ideal Industries, Inc.
- Kearney-National.
- McGill Mfg.
- O-Z/Gedney Co.
- Post Glover Resistors, Inc.
- Raco, Inc.
- Thomas & Betts Corp.
- W.H. Salisbury & Co.
- Utilco Co.
- DMC Power

GROUNDING AND BONDING PRODUCTS

Products: Of types indicated and of sizes and ratings to comply with NEC. Where types, sizes, ratings, and quantities indicated are in excess of NEC requirements, the more stringent requirements and the greater size, rating, and quantity indications govern.

Conductor Materials: Copper.

WIRE AND CABLE CONDUCTORS

General: Comply with Division 16 Section "Wires and Cables." Conform to NEC Table 8, except as otherwise indicated, for conductor properties, including stranding.

Equipment Grounding Conductor: Green insulated.

Grounding Electrode Conductor: Bare Stranded cable.

Bare Copper Conductors: Conform to the following:

- Solid Conductors: ASTM B-3.
- Assembly of Stranded Conductors: ASTM B-8.
- Tinned Conductors: ASTM B-33.

MISCELLANEOUS CONDUCTORS

Ground Bus: Bare annealed copper bars of rectangular cross section.

Braided Bonding Jumpers: Copper tape, braided No. 30 gage bare copper wire, terminated with copper ferrules.

Bonding Strap Conductor/Connectors: Soft copper, 0.05 inch thick and 2 inches wide, except as indicated.

CONNECTOR PRODUCTS

General: Listed and labeled as grounding connectors for the materials used.

Pressure Connectors: High-conductivity-plated units.

FRONT ST PHASE 4 UG INFRASTRUCTURE UPGRADE (T2) CITY OF GEORGETOWN

Bolted Clamps: Heavy-duty units listed for the application.

Exothermic Welded Connections: Provided in kit form and selected for the specific types, sizes, and combinations of conductors and other items to be connected.

Swage Compression Connections: Swage ground connection system as manufactured by DMC Power may be installed as an alternative to exothermic welded connections.

GROUNDING ELECTRODES

Ground Rods: Copper-clad steel with high-strength steel core and electrolytic-grade copper outer sheath, molten welded to core.

Size: 5/8 inch by 8 feet.

EXECUTION

APPLICATION

Install grounding at transformers in accordance with drawings. Bond transformer enclosures to the grounding system.

Install grounding in manholes and pull boxes to bond all wall support channels to existing grounding electrodes. If the existing grounding electrodes are corroded such that the copper cladding is not intact or it is not practicable to make exothermic weld connections to the ground conductors, notify the Engineer.

GROUNDING ELECTRODES

Provide cone pointed driven ground rods driven full depth plus 6 inches, installed to provide an earth ground of the appropriate value for the particular equipment being grounded.

If the specified ground resistance is not met, an additional ground rod must be provided in accordance with the requirements of NFPA 70 (placed not less than 6 feet from the first rod). Should the resultant (combined) resistance exceed the specified resistance, measured not less than 48 hours after rainfall, notify the Engineer immediately.

CONNECTIONS

General: Make connections in such a manner as to minimize possibility of galvanic action or electrolysis. Select connectors, connection hardware, conductors, and connection methods so metals in direct contact will be galvanically compatible.

Use electroplated or hot-tin-coated materials to assure high conductivity and make contact points closer in order of galvanic series.

Make connections with clean bare metal at points of contact.

Coat and seal connections involving dissimilar metals with inert material such as red lead paint to prevent future penetration of moisture to contact surfaces.

Exothermic Welded or Swage Compression Connections: Use for connections to structural steel and for underground connections. Install at connections to ground rods and plate electrodes. Comply with manufacturer's written recommendations. Welds that are puffed up or that show convex surfaces indicating improper cleaning are not acceptable.

**FRONT ST PHASE 4 UG INFRASTRUCTURE UPGRADE (T2)
CITY OF GEORGETOWN**

Terminate insulated equipment grounding conductors for feeders and branch circuits with pressure-type grounding lugs. Where metallic raceways terminate at metallic housings without mechanical and electrical connection to the housing, terminate each conduit with a grounding bushing. Connect grounding bushings with a bare grounding conductor to the ground bus in the housing. Bond electrically noncontinuous conduits at both entrances and exits with grounding bushings and bare grounding conductors.

Tighten grounding and bonding connectors and terminals, including screws and bolts, in accordance with manufacturer's published torque tightening values for connectors and bolts. Where manufacturer's torqueing requirements are not indicated, tighten connections to comply with torque tightening values specified in UL 486A and UL 486B.

Compression-Type Connections: Use hydraulic compression tools to provide the correct circumferential pressure for compression connectors. Use tools and dies recommended by the manufacturer of the connectors. Provide embossing die code or other standard method to make a visible indication that a connector has been adequately compressed on the ground conductor.

Moisture Protection: Where insulated ground conductors are connected to ground rods or ground buses, insulate the entire area of the connection and seal against moisture penetration of the insulation and cable.

FIELD QUALITY CONTROL

Tests: Measure the resistance of each ground rod using the fall-of-potential method defined in IEEE 81. If the resistance is greater than 25 ohms, notify the Engineer. Maintain records of all resistance tests.

(END OF SECTION)

**FRONT ST PHASE 4 UG INFRASTRUCTURE UPGRADE (T2)
CITY OF GEORGETOWN**

APPENDIX A – BID TABLE







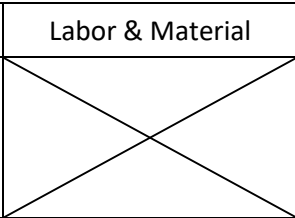
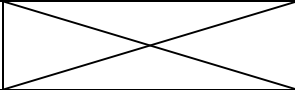
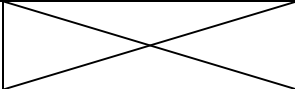
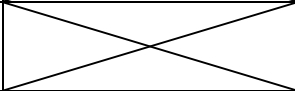
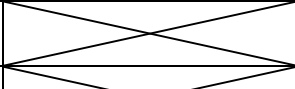
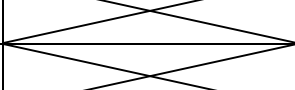
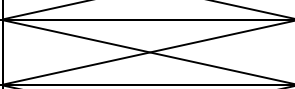
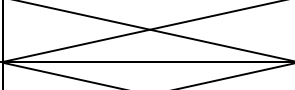
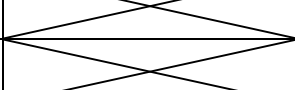
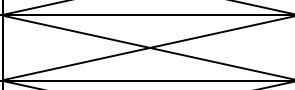

UNIT PRICES

Unit prices quoted and accepted shall apply throughout the life of the contract, except as otherwise specifically noted. Unit prices shall be applied, as appropriate, to compute the total value of changes in the scope of the work, all in accordance with the contract documents.

The unit adjustment prices will be a major consideration in the bid evaluations.

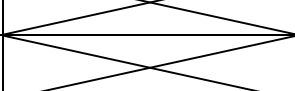
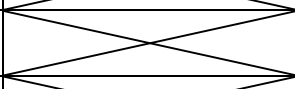
	Unit Adjustment Price	
	Labor & Material	Labor Only
Conduit trenching, machine dug, per cubic yard	67.66	
Conduit trenching, hand dug, per cubic yard	405.94	
Rock excavation, per cubic yard	3,100.78	
Cut and replace asphalt pavement (furnish all materials), per square yard	116.28	
Cut and replace decorative concrete sidewalk (furnish all materials), per square yard	155.04	
Re-seed and mulch (furnish all materials), per square yard	232.56	
Re-sod (furnish all materials), per square yard	116.28	
Concrete for transformer pads, including reinforcing and formwork, per cubic yard	1,550.39	
Bore under roadway, including 4-inch conduit installation, per foot	38.76	
Setup for bore, including excavation and backfill of pit, each	155.04	
Conduit, including fittings and supports, installed, per foot:		
4 inch PVC schedule 40 direct buried	32.73	
1-1/2 inch rigid steel	101.48	
2 inch rigid steel	135.31	
2 inch flexible liquid-tight conduit	20.30	

**FRONT ST PHASE 4 UG INFRASTRUCTURE UPGRADE (T2)
CITY OF GEORGETOWN**

	Unit Adjustment Price	
	Labor & Material	Labor Only
Install 5/8 inch by 10 foot ground rod, install, test resistance, and connect to equipment with copper conductor (furnish exothermic welded connections to ground rod), each		260.89
No. 2/0 AWG bare copper ground wire, installed, per foot		40.95
No. 2/0 AWG copper exothermic welded connection, installed, each		126.26
Three No. 1/0 AWG aluminum 15 kV URD cables in conduit, installed, per foot		23.51
600 V cable in conduit, installed, per foot:		
Four 500 kcmil and one 350 kcmil aluminum		75.62
Three 500 kcmil and one 350 kcmil aluminum		65.15
Three 750 kcmil and one 350 kcmil aluminum		
Triplex, 4/0-2/0 AWG aluminum		
Triplex, 2/0-2/0 AWG aluminum		
Quadruplex, 4/0-2/0 AWG aluminum		
One 2/0 AWG aluminum		
15 kV loadbreak elbow, installed, each		496.68
600 V submersible connector, six 2-hole NEMA pad outlets with insulating sleeves, installed, each		1,223.68
600 V submersible connector, three 1-hole NEMA pad outlets with insulating sleeves, installed, each		1,210.15
600 V terminal lugs, installed, each:		
750 kcmil aluminum 2-hole NEMA		
500 kcmil aluminum 2-hole NEMA		64.17
350 kcmil aluminum 2-hole NEMA		53.42
No. 4/0 AWG aluminum 2-hole NEMA		49.07

**APPENDIX A
A-2**

**FRONT ST PHASE 4 UG INFRASTRUCTURE UPGRADE (T2)
CITY OF GEORGETOWN**

	Unit Adjustment Price	
	Labor & Material	Labor Only
No. 2/0 AWG aluminum 2-hole NEMA	 	49.57
No. 10 AWG aluminum 2-hole NEMA	 	33.83
No. 12 AWG aluminum 2-hole NEMA	 	33.83
No. 2/0 AWG aluminum 1-hole NEMA	 	51.41
No. 10 AWG aluminum 1-hole NEMA	 	33.83
No. 12 AWG aluminum 1-hole NEMA	 	33.83
Cable support bracket, stainless steel slotted channel, 18" long, 1-5/8" x 1-5/8", 12 GA, installed, each	 	377.76
Cable clamp, 1-7/8", polymer, with stainless steel strap, installed, each	 	131.72
Manhole wall support, stainless steel slotted channel, 72" long, 13/16" x 1-5/8", 12 GA, installed, each	 	193.91
Pull box wall support, stainless steel slotted channel, 38" long, 13/16" x 1-5/8", 12 GA, installed, each	 	193.91
Perform dc hipot cable test on completed single phase 15 kV cable section, each	676.57	
Perform dc hipot cable test on completed three phase 15 kV cable section, each	1,353.13	
Install 50 kVA single phase pad-mounted transformer, each	 	1,623.76
Install 100 kVA single phase pad-mounted transformer	 	1,623.76
Install 167 kVA single phase pad-mounted transformer	 	1,623.76

**FRONT ST PHASE 4 UG INFRASTRUCTURE UPGRADE (T2)
CITY OF GEORGETOWN**

SUBCONTRACTORS

Provide a list of all Subcontractors with name, address, and phone number. The Contractor shall not change Subcontractors without written permission of the Owner.

Contractor Name	Contact Information	Work Subcontracted



120 North Fraser Street • Georgetown, SC 29440 • (843) 545-4000

ACTION ITEM

Council Meeting Date:	March 19, 2026
Department:	Police
Issue Under Consideration:	Motion to Approve a Memorandum of Understanding (MOU) Mutual Aid Narcotics and Vice Enforcement between Georgetown Police Department and Georgetown County Sheriff's Department.
Amount Requested:	
In Current Budget?:	
If not, please explain:	
Financial Impact:	
Points to Consider:	
Options:	
Staff Recommendation:	

Reviews:

Tenetra Sellers	Created/Initiated	Approver
William Pierce	Approved	Approver
Scott Whittier	Approved	Approver
Stephanie Buccione	Final Approval	Approver

Attachments:

1. SKM_C360i26030410170

MEMORANDUM OF UNDERSTANDING

STATE OF SOUTH CAROLINA
COUNTY OF GEORGETOWN

MUTUAL AID
NARCOTICS AND VICE ENFORCEMENT

This Agreement is made and entered into this 17 day of February, 2026, by and between the Georgetown County Sheriff's Office, by and through Sheriff Carter Weaver (hereinafter referred to as "Sheriff"), and the City of Georgetown Police Department, by and through Chief William Pierce (hereinafter referred to as "City") The Sheriff and City hereafter collectively referred to as the Parties.

RECITALS:

Pursuant to Article VIII, Section 13 of the Constitution of the State of South Carolina and Section 6-1-20 of the South Carolina Code of Laws, political subdivisions may enter into agreements for the joint administration of governmental functions and the sharing of services to provide joint public facilities and services when considered mutually desirable.

The Parties have authority to enter agreements as appears to them necessary and proper to protect and promote the security and general welfare and preserving the health, peace, order, and good government in the county and city.

The trade and activity of illegal narcotics and vice activities present a risk and harm to the residents of Georgetown County.

The Parties desire to cooperate in the enforcement of narcotics and vice laws within Georgetown County through the assignment of City Police Officers to the Sheriff's Office Narcotics/Vice Unit.

Therefore, the Parties, both and each for itself, wish to enter into this agreement for mutual aid, joint public facilities and services for the purposes and scope stated herein.

TERMS and SCOPE:

The Parties, both and each for itself expressly acknowledge and agree as follows:

1. Assignment of Officers

The City agrees to assign sworn City of Georgetown Police Officers to the Georgetown County Sheriff's Office Narcotics/Vice Unit (the Unit). All assigned officers shall work under the operational supervision and direction of the Sheriff or his designee while assigned to the Unit.

2. Authority

While assigned to the Unit, the City officers shall have full law enforcement authority throughout Georgetown County, consistent with South Carolina law, for the enforcement of state criminal statutes and county ordinances.

3. Chain of Command

Assigned officers shall remain employees of the City of Georgetown, however, for operational purposes and all work for or within the Unit, they shall report to and be supervised by the Sheriff's Office chain of command, and daily assignments, investigations, enforcement actions, and tactical operations shall be directed by the Sheriff or his designee.

4. Vehicles and Equipment

All assigned officers shall be subject to the policies and procedures of the Sheriff's Office. Assigned officers may operate Sheriff's Office vehicles and utilize Sheriff's Office equipment while performing duties within the Unit. All assigned officers only use Sheriff's vehicles and equipment in full compliance with Sheriff's Office policies and procedures.

5. Compensation and Benefits

Unless otherwise agreed in writing by the Parties, assigned officers shall remain employees of the City for purposes of salary, benefits, workers' compensation, retirement, and related employment matters.

6. Liability and Indemnification

Each party shall be liable and responsible for the acts and omissions of its respective employees to the extent provided by law. Nothing in this Agreement shall be construed to waive sovereign immunity or any protections afforded under the South Carolina Tort Claims Act.

7. Term and Termination

This Agreement shall remain in effect until terminated by either party upon 45 (45) days written notice to the other party, unless earlier terminated by mutual agreement.

8. Notices

Any notice required under this Agreement shall be in writing and delivered to the respective offices of the Sheriff and Chief of Police.

GEORGETOWN COUNTY SHERIFF'S OFFICE

By: Carter Weaver
Carter Weaver, Sheriff

Witness: Wayne M. Owen

CITY OF GEORGETOWN POLICE DEPARTMENT

By: _____
William Pierce, Chief of Police

Witness: _____



120 North Fraser Street • Georgetown, SC 29440 • (843) 545-4000

ACTION ITEM

Council Meeting Date:	March 19, 2026
Department:	Public Works
Issue Under Consideration:	Motion to approve the purchase of a garbage truck for the Waste Management division of Public Works from Amick Equipment in the amount of \$377,241.44.
Amount Requested:	\$377,241.44
In Current Budget?:	\$350,000.00
If not, please explain:	The City Administrator and Finance Director have approved reallocating \$27,241.44 from remaining balances in the GPS Tracking System and Roll-Out Cart projects, ensuring full funding for this purchase without requiring additional budget resources.
Financial Impact:	This transfer provides the additional amount needed to complete the acquisition with no negative impact on the General Fund or operational budgets. No new appropriations are required.
Points to Consider:	<ul style="list-style-type: none"> • City Council approved the Letter of Intent to Purchase the 3rd automated garbage truck in August 2025. • As our community continues to experience significant housing growth, the adoption of automated garbage trucks remains essential to sustaining high-quality, reliable solid waste services for all residents. • These vehicles have enhanced operational efficiency and greatly improved employee safety by

	<p>eliminating the need for workers to ride on the back of collection trucks. While automation significantly reduces injury risks and supports long-term workforce well-being, there remains a necessary role for rear-loader operations to ensure continued service for back-door customers who depend on this accommodation.</p> <ul style="list-style-type: none"> • The automated fleet is capable of fully supporting twice-weekly residential collections operating four days per week, ensuring consistent service as our population expands. Additionally, this equipment allows the City to maintain a seven-day-a-week collection within the downtown business district, reinforcing local commerce and contributing to the continued economic vitality of our community. • Amick Equipment has confirmed that the third automated garbage truck is nearing completion and will be ready for purchase pending Council approval. If approved, the City can expect delivery of the vehicle before June 30th.
Options:	Council to approve or disapprove this purchase.
Staff Recommendation:	Staff recommends Council approve this purchase of this garbage truck.

Reviews:

Ashley Gaddy	Created/Initiated	Approver
Natrona Simmons	Approved	Approver
Kathy Vermeland	Approved	Approver
Scott Whittier	Approved	Approver
Stephanie Buccione	Final Approval	Approver

Attachments:

1. 30742A NW QC Photos
2. Emails for Amick
3. LOI - Georgetown to Amick - 20250825
4. Quote - Amick to Georgetown - 20250725



Truck Photos

New Way Trucks is pleased to provide photos of your truck for review. Please note the photos are taken during the quality inspection process indicating the truck is nearing completion. You will be contacted by the New Way logistics team when the truck is completed and ready for shipment. Please direct any comments, questions, or concerns regarding the subject truck to your regional sales manager.

Order information

201876-1-1

Amick Equipment Co., Inc.

02/16/2026

30742A

ASL 31Yd - 27Yd Body

08:30 AM

MS - Wolverine

Johnathan Scales



Truck Photos

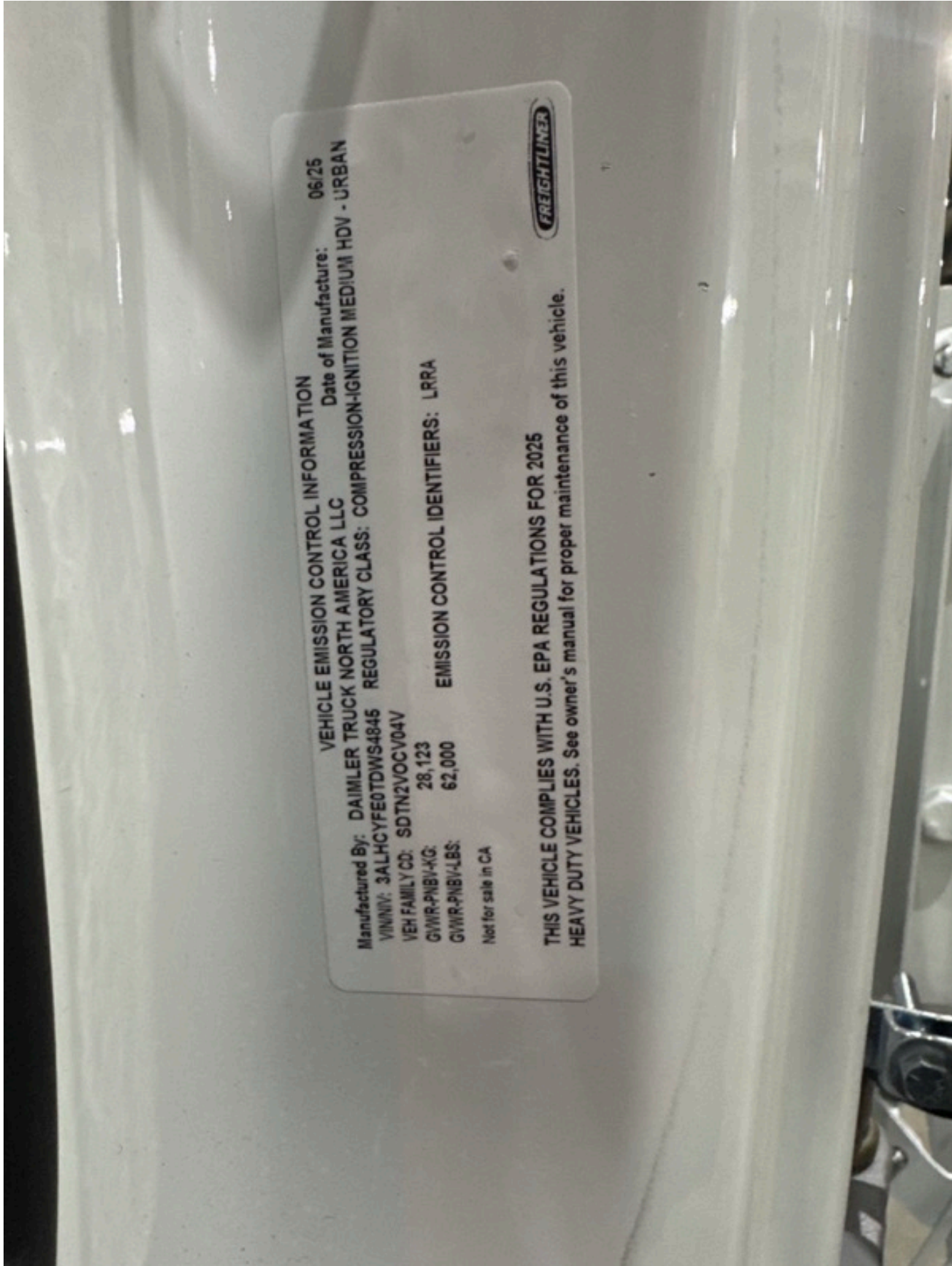



Truck Photos





Truck Photos

Cab Photos:



Truck Photos





Truck Photos





Truck Photos





Truck Photos

Body Photos:



Truck Photos





Truck Photos





Truck Photos





Truck Photos





Truck Photos





Truck Photos





Truck Photos



Truck Photos





Truck Photos





Truck Photos





Truck Photos





Truck Photos





Truck Photos





Truck Photos





Truck Photos



In Cab Photos:



Truck Photos





Truck Photos





Truck Photos



Truck Photos





Truck Photos





Truck Photos

Additional Photos:



Fw: 3rd Automated Garbage Truck

From Harrison, Ashley <aharrison@georgetownsc.gov>
Date Tue 3/3/2026 10:14 AM
To Harrison, Ashley <aharrison@georgetownsc.gov>

From: Vermeland, Kathy <kvermeland@georgetownsc.gov>
Sent: Wednesday, February 25, 2026 10:41 AM
To: Simmons, Natrona <nsimmons@georgetownsc.gov>; Whittier, Scott <swhittier@georgetownsc.gov>
Cc: Jagger, Eliza <EJagger@georgetownsc.gov>
Subject: RE: 3rd Automated Garbage Truck

Natrona,

I am good with proceeding with this.

Thanks,

Kathy Vermeland

Kathy Vermeland, CGFO | Director
City of Georgetown Finance Department
1134 North Fraser Street (29440) : PO Drawer 939, Georgetown, SC 29442
Contact | **P:** 843-545-4031 | **F:** 843-546-5435 | **E:** kvermeland@georgetownsc.gov
www.georgetownsc.gov



where southern time
MEETS MARITIME

DiscoverGeorgetownSC.com

All e-mail correspondence to and from this address may be subject to public disclosure under the South Carolina Freedom of Information Act (FOIA). This correspondence is intended exclusively for the individual or entity to which it is addressed and may contain information that is proprietary, privileged, confidential or otherwise legally exempt from disclosure.

From: Simmons, Natrona <nsimmons@georgetownsc.gov>
Sent: Wednesday, February 25, 2026 9:39 AM
To: Vermeland, Kathy <kvermeland@georgetownsc.gov>; Whittier, Scott <swhittier@georgetownsc.gov>
Subject: Re: 3rd Automated Garbage Truck

Under Waste Management:
New Garbage Truck \$377,241.44 , Budgeted \$350,000 (\$27,241.44)

Request to utilize funds remaining in the following accounts in Waste Management:

	DESCRIPTION	BUDGETED	SPENT	BALANCE
0035.31.00.9000.4300	GPS TRACKING SYSTEM	\$35,000	\$14,102.06	\$20,897.94
	DOWNTOWN DISTRICT ROLL OUT CARTS	\$5,000	\$0	\$5,000.00
	RESIDENTIAL ROLL OUT CARTS	55,000	\$17,22.50	\$36,343.00 -\$1,434.50

Natrona Simmons | Public Works Director

City of Georgetown Public Works Department

125 North Kaminski Street (29440) : PO Drawer 939, Georgetown, SC 29442
Contact | **P:** 843-545-4701 | **F:** 843-520-0682 | **E:** nsimmons@georgetownsc.gov
www.georgetownsc.gov



where southern time
MEETS MARITIME

DiscoverGeorgetownSC.com

All e-mail correspondence to and from this address may be subject to public disclosure under the South Carolina Freedom of Information Act (FOIA). This correspondence is intended exclusively for the individual or entity to which it is addressed and may contain information that is proprietary, privileged, confidential or otherwise legally exempt from disclosure.

From: Vermeland, Kathy <kvermeland@georgetownsc.gov>
Sent: Tuesday, February 24, 2026 1:04 PM
To: Whittier, Scott <swhittier@georgetownsc.gov>; Simmons, Natrona <nsimmons@georgetownsc.gov>
Subject: RE: 3rd Automated Garbage Truck

Natrona/Scott,

We cannot use funds from the General Fund Capital Account to fund Waste Management purchases. You will have to find the extra money needed within the fund.

Thanks,

Kathy Vermeland

Kathy Vermeland, CGFO | Director
City of Georgetown Finance Department
1134 North Fraser Street (29440) : PO Drawer 939, Georgetown, SC 29442
Contact | **P:** 843-545-4031 | **F:** 843-546-5435 | **E:** kvermeland@georgetownsc.gov
www.georgetownsc.gov



where southern time
MEETS MARITIME

DiscoverGeorgetownSC.com

All e-mail correspondence to and from this address may be subject to public disclosure under the South Carolina Freedom of Information Act (FOIA). This correspondence is intended exclusively for the individual or entity to which it is addressed and may contain information that is proprietary, privileged, confidential or otherwise legally exempt from disclosure.

From: Whittier, Scott <swhittier@georgetownsc.gov>
Sent: Tuesday, February 24, 2026 8:02 AM
To: Simmons, Natrona <nsimmons@georgetownsc.gov>
Cc: Vermeland, Kathy <kvermeland@georgetownsc.gov>
Subject: RE: 3rd Automated Garbage Truck

Natrona,

I am good with utilizing these funds to cover the shortfall of what was budgeted to purchase the new automated garbage truck if we are able to move funds from 0012.26 over to 0035.31.

Kathy,

Please confirm these funds can be used.

Thank you,

Scott Whittier | City Administrator
City of Georgetown Administrative Department
417 Wood Street (29440) : PO Box 939, Georgetown, SC 29442
Contact | **P:** 843-545-4001 | **F:** 843-527-6173 | **E:** swhittier@georgetownsc.gov
www.georgetownsc.gov

All e-mail correspondence to and from this address may be subject to public disclosure under the South Carolina Freedom of Information Act (FOIA). This correspondence is intended exclusively for the individual or entity to which it is addressed and may contain information that is proprietary, privileged, confidential or otherwise legally exempt from disclosure.

From: Simmons, Natrona <nsimmons@georgetownsc.gov>
Sent: Monday, February 23, 2026 3:19 PM
To: Whittier, Scott <swhittier@georgetownsc.gov>
Subject: Re: 3rd Automated Garbage Truck

Scott,

Below are funds available to used towards the purchase of the 3rd automated truck. Please let me know if I can move forward using these available funds to cover the purchase of this equipment. Thank you,

0035.31.00.9000.4200	LETTER OF INTENT TO PURCHASE NEW AUTOMATED GARBAGE TRUCK, NO. 3	350,000.00	(\$27,241.44) REMAINING BALANCE NEEDED PURCHASE ORDER (\$377,241.44)
0012.26.00.9000.4300	PWD : TRAFFIC CONTROL BOARD	20,000.00	
	SOUTHERN VAC	10,812.00	9,188.00
0035.31.00.9000.4300	GPS TRACKING SYSTEM FOR GARBAGE TRUCKS	35,000.00	
	3RD EYE VISION	14,102.06	20,897.94

Natrona Simmons | Public Works Director

City of Georgetown Public Works Department

125 North Kaminski Street (29440) : PO Drawer 939, Georgetown, SC 29442
 Contact | **P:** 843-545-4701 | **F:** 843-520-0682 | **E:** nsimmons@georgetownsc.gov
www.georgetownsc.gov



where southern time
MEETS MARITIME

DiscoverGeorgetownSC.com

All e-mail correspondence to and from this address may be subject to public disclosure under the South Carolina Freedom of Information Act (FOIA). This correspondence is intended exclusively for the individual or entity to which it is addressed and may contain information that is proprietary, privileged, confidential or otherwise legally exempt from disclosure.

From: Whittier, Scott <swhittier@georgetownsc.gov>
Sent: Friday, February 20, 2026 4:39 PM
To: Simmons, Natrona <nsimmons@georgetownsc.gov>
Subject: RE: 3rd Automated Garbage Truck

Great! I would put it on the March agenda so you can get it as soon as you can.

Scott Whittier | City Administrator

City of Georgetown Administrative Department
 417 Wood Street (29440) : PO Box 939, Georgetown, SC 29442
 Contact | **P:** 843-545-4001 | **F:** 843-527-6173 | **E:** swhittier@georgetownsc.gov
www.georgetownsc.gov

All e-mail correspondence to and from this address may be subject to public disclosure under the South Carolina Freedom of Information Act (FOIA). This correspondence is intended exclusively for the individual or entity to which it is addressed and may contain information that is proprietary, privileged, confidential or otherwise legally exempt from disclosure.

From: Simmons, Natrona <nsimmons@georgetownsc.gov>
Sent: Friday, February 20, 2026 2:03 PM
To: Whittier, Scott <swhittier@georgetownsc.gov>
Subject: Fw: 3rd Automated Garbage Truck

Scott,

This truck is ready for the City 😊... Please see email below from Amick and photos attached. I can plan to place this on the Agenda in March, or should I wait till April after budget retreat?

Natrona Simmons | Public Works Director

City of Georgetown Public Works Department

125 North Kaminski Street (29440) : PO Drawer 939, Georgetown, SC 29442
Contact | **P:** 843-545-4701 | **F:** 843-520-0682 | **E:** nsimmons@georgetownsc.gov
www.georgetownsc.gov



where southern time
MEETS MARITIME

DiscoverGeorgetownSC.com

All e-mail correspondence to and from this address may be subject to public disclosure under the South Carolina Freedom of Information Act (FOIA). This correspondence is intended exclusively for the individual or entity to which it is addressed and may contain information that is proprietary, privileged, confidential or otherwise legally exempt from disclosure.

From: Dave Hull <d.hull@amickequipment.com>
Sent: Friday, February 20, 2026 8:45 AM
To: Simmons, Natrona <nsimmons@georgetownsc.gov>
Cc: Williams, Isaac <iwilliams@georgetownsc.gov>
Subject: RE: 3rd Automated Garbage Truck

Natrona,

Please see the updated quote for this Automated Garbage truck. There is no change in pricing from the Letter of Intent attached as well. In fact, this truck completed way faster then expected. On Monday I received the QC pictures for it from New Way. I have attached the pictures of your truck. Typically when I receive pictures it is 3-4 weeks before the truck arrives at our shop. The we will need a few weeks to get the PDI and camera install done. I was wrong yesterday when we talked about us adding the "Live View" to this truck in house, we have 3rd eye come add that part as well. We will install the Safety Vision version, not the 3rd eye one.

However, once the truck comes in and we get our part done, we will hold the truck until you are able to take it since it did come early. Thank you and let me know if you have any questions.

DAVE HULL
843.917.8020

From: Simmons, Natrona <nsimmons@georgetownsc.gov>
Sent: Thursday, February 19, 2026 3:38 PM
To: Dave Hull <d.hull@amickequipment.com>
Cc: Williams, Isaac <iwilliams@georgetownsc.gov>
Subject: 3rd Automated Garbage Truck

CAUTION: This email originated from outside your organization. Exercise caution when opening attachments or clicking links, especially from unknown senders.

Hey Dave,

Just left you a voicemail. The City Administrator would like us to get this request on the agenda in March, and I will need to obtain an updated proposal along with the timeframe for this equipment. Thanks so much, talk to you soon!

Natrona Simmons | Public Works Director

City of Georgetown Public Works Department

125 North Kaminski Street (29440) : PO Drawer 939, Georgetown, SC 29442
Contact | **P:** 843-545-4701 | **F:** 843-520-0682 | **E:** nsimmons@georgetownsc.gov
www.georgetownsc.gov



where southern time
MEETS MARITIME

DiscoverGeorgetownSC.com

All e-mail correspondence to and from this address may be subject to public disclosure under the South Carolina Freedom of Information Act (FOIA). This correspondence is intended exclusively for the individual or entity to which it is addressed and may contain information that is

proprietary, privileged, confidential or otherwise legally exempt from disclosure.

MAYOR
CAROL JAYROE

CITY ADMINISTRATOR
SCOTT WHITTIER

CITY CLERK
STEPHANIE BUCCIONE



COUNCIL MEMBERS
JIM CLEMENTS
MAYOR PRO TEMPORE

JONATHAN ANGNER
BRUCE CARL
ERIN ETHRIDGE
JIMMY MORRIS
TAMIKA WILLIAMS-OBENG

Executive Office
(843) 545-4001

August 25, 2025

Mr. Dave Hull
Amick Equipment
1 Wolverine Dr.
Booneville, MS 38829

Dear Mr. Hull:

This letter serves as intent to purchase the third (3rd) New Way Sidewinder XTR automated garbage truck subject to the specifications provided under State Contract no.26-10-0422 Item #338, a quote prepared by Amick Equipment on July 25, 2025, in the amount of \$377,241.44.

At its council meeting on August 21st, Georgetown City Council approved submitting this letter of intent to purchase. Please understand the purchase is further subject to approval from city council during the FY 2027 budget process as well as approval for a financing mechanism after the budget is adopted in mid-2026.

If you have any questions please contact the Fleet Superintendent, Isaac Williams at iwilliams@georgetownsc.gov or 843-545-4704.

Sincerely,

Scott Whittier

Scott Whittier
City Administrator

cc: Mayor Carol Jayroe and Members of Council
Kathy Vermeland, Finance Director
Natrona Simmons, Public Works Director
Isaac Williams, Fleet Superintendent



For NCSA Contract Purchases:
 Please send P.O. to Amick & NCSA including:
 Contract #, Spec #, Contact Info, & Fed. Tax ID #
 NCSA: kmitman@ncsheriffs.net
[LINK: NCSA Terms & Conditions](#)

CONTRACT #
26-10-0422
ITEM #
338

END USER: GEORGETOWN, CITY OF
 NATRONA SIMMONS
 EQUIPMENT INSTALL NEW WAY TRUCKS - MS,
 LOCATION: 1 WOLVERINE DR.. BOONEVILLE. MS 38829

Description

Contract Price

MODEL: **NEW WAY SIDEWINDER**
 SIZE: **31 YD**
 PAINT: **WHITE**
 WARRANTY: **NEW WAY: 1 YR BODY & HYDRAULIC, 2 YR CYLINDER**

STANDARD EQUIPMENT INCLUDED

CAN-BUS ELECTRONIC CONTROL SYSTEM W/ XL IN CAB DISPLAY - OPERATOR FEEDBACK & 12 FT. REACH & 1000 LBS. LIFT CAPACITY
 ARM STOWED LOCK - AUTOMATIC PNEUMATIC CAM LOCK
 ARM CONTROL JOYSTICK - CENTER CONSOLE - PROPORTIONAL HYDRAULIC CONTROL FOR ELECTRIC / HYDRAULIC BODY CONTROLS (ILO PNEUMATICS)
 PROXIMITY SWITCH - ARM STOWED SENSOR - ILO WIRE STYLE LIMIT SWITCH
 PROXIMITY SWITCHES - PACKER POSITION, TAILGATE, BODY UP, ARM POSITION
 CAN-BUS ELECTRONIC CONTROL SYSTEM W/ XL IN CAB DISPLAY - OPERATOR FEEDBACK & PTO HOUR METER
 HINGED HOPPER DOOR FOR EASY ACCESS - INCLUDES SAFETY PTO KILL SWITCH
 FRONT MOUNT VANE PUMP - DUAL PUMP - WORK AT IDLE HYDRAULICS.
 NOTE: FRONT PUMP REQUIRES FRONT ENGINE PTO PROVISIONS ON CHASSIS
 NOTE: HOT SHIFT TRANSMISSION MOUNT PTO RESULTS IN UPCHARGE.
 LED BODY LIGHTS INCLUDING REVERSE AND LICENSE PLATE
 INTEGRATED MULTIFUNCTION LED STROBE LIGHTS: (2) UPPER TAILGATE & (2) LOWER
 SAFETY KIT - FIRE EXTINGUISHER, 10LBS. & TRIANGLE KIT
 ACRYLIC URETHANE ENAMEL - AXALTA IMRON ELITE 5000
 ARM POWDER COAT: NW SAFETY YELLOW
 STEEL SPECIFICATIONS, STD.:
 BODY SIDES: 10GA AR450
 PACKER PANEL: 1/4" AR450
 BODY FLOOR: 8GA AR450
 TAILGATE BACK: 10GA AR450
 HOPPER FLOOR & SIDES: 1/4" HARDOX 450
 RAM GUIDE: 3/8" X 3" AR400 WEAR STRIPS
 ZINC PLATED HYDRAULIC TUBES OFFER DURABILITY AND HEAT DISSIPATION
 INDUCTION HARDENED PACK CYLINDERS WITH SCRAPERS
 QUICK DISCONNECT PORTS FOR PRESSURE GAUGE
 TROUGH CLEANOUT TOOL
 CART COUNTING DEVICE
 BOLT-ON ICC BUMPER
 2025 IMPROVEMENTS:
 ELECTRICAL IMPROVEMENTS: REDUCED CAN BUS MODULES FROM 5 TO 2. REDUCED WIRING
 IMPROVED GRIPPER FINGERS - ELIMINATING RUBBER PUCKS
 SELECTABLE GRIPPER PRESSURE SETTINGS
 RAKE TEETH ABOVE HOPPER OPENING - REDUCES FALLBACK IN HOPPER.
 HYDRAULIC FILTER BYPASS INDICATOR ON DISPLAY
 HYDRAULIC OIL TEMP INDICATOR ON DISPLAY
 REDUCED BODY WEIGHT.

OPTIONAL UPGRADES AND ACCESSORIES INCLUDED

HOPPER FLOOR AND SIDE LINER .188 AR450
 ARM SPILL SHIELD
 HINGED FRONT SPLASH SHIELD
 HOPPER CLEANOUT CHUTE EXTENSION BOTH SIDES
 PARTIAL HOPPER WIND DEFLECTOR
 CHROMIUM OVERLAY / SUPER TRACK
 HYDRAULIC HOPPER COVER
 HOPPER ACCESS LADDER
 SHOVEL / BROOM RACK
 LED MID BODY BACKUP LIGHTS (2)
 LED BACKUP LIGHTS TAILGATE MOUNTED (2)
 LED WORK LIGHTS (1) HOPPER (1) ARM
 STROBE LIGHT CENTER TAILGATE

LED INTEGRATED STROBE SYSTEM (2) FRONT BULKHEAD
 3RD EYE QUAD CAMERA SYSTEM (1) BACKUP (1) HOPPER (1) ARM (1) SS BLINDSPOT
 HOTSHIFT PTO, TANDEM VANE, DRIVE LINE
 REMOTE GREASE ZERKS TAILGATE AND UPPER CYLINDER HINGE PINS
 REMOTE GREASE ZERKS PACKER AND BODY LIFT PINS
 ZERKS ON HOPPER DOOR AND COVERS
 MANUAL AUTOPACK
 ARM CONTROLS UNDER CURBSIDE SEAT
 LOW FLUID LEVEL SWITCH INDICATOR AND SHUTDOWN
 NYLON SLEEVES ON HOSES
 STEEL TOOL BOX FRAME MOUNTED 18X18X24
 FIRE EXTINGUISHER 20 LB. (UPGRADE)
 PARTS MANUAL

LOCAL OPTIONS INCLUDED

3RD EYE DVR SYSTEM WITH ADDITIONAL FORWARD FACING CAMERA

DEALER SERVICES INCLUDED

FREIGHT TO AMICK EQUIPMENT
 BODY PRE-DELIVERY INSPECTION
 AECI MOBILE ON-SITE WARRANTY PKG., 12 MO.
 ON-SITE TRAINING - PROVIDED BY REQUEST

DELIVERY OPTION INCLUDED:

AECI DELIVERS TO END USER.

COMMENTS:

Pricing Disclaimer: Due to recent tariff announcements, steel prices and foreign components are expected to increase noticeably. This may result in retroactive price increases and surcharges on ordered equipment. Amick Equipment will absorb these increases when possible but may pass them along as announced by each of the manufacturer. We appreciate your understanding during this volatile period.

Subtotal:	\$	222,529.00
Contract Discount - Options / Accessories:	\$	(1,755.06)
Subtotal:	\$	220,773.94

Chassis Description

MODEL: **2026 FREIGHTLINER M2 106 PLUS**
 GVWR: 62000 LBS
 ENG & TRAN: CUMMINS L9 DIESEL / ALLISON 3000 RDS A/T
 PAINT: WHITE
 COMMENTS: SEE CHASSIS SPECIFICATIONS FOR COMPLETE DETAILS.
 FONTAINE DUAL STEER PREMIUM CONVERSION
 2YR / UNLIMITED MILE BASE VEHICLE WARRANTY
 2YR / 250K MILE CUMMINS L9 ENGINE WARRANTY
 3YR / UNLIMITED MILE ALLISON WARRANTY
 1YR / UNLIMITED MILE TOWING

Chassis Subtotal: \$ 155,945.00

Unit Subtotal: \$ 376,718.94

Tax - Motor Vehicle (SC IMF / NC HUT): \$ 522.50

Unit Purchase Price: \$ 377,241.44

Payment Terms:

MUNI & CHASSIS DEALERS: NET 15
 * C.O.D Discount Available
 * Late Fee: 1%

Chassis ETA: 1/30/26 Scheduled Completion Date
 Equipment Build Estimate: 180 Days after receipt of CHASSIS

Completion ETA: 8/18/26 Scheduled Completion Date

Note: ETAs are based on schedule at time of quote and are subject to change.

Chassis Dealers: Please include floorplan in chassis pricing,

QUOTED BY: Dave Hull
 DATE: 2/20/2026
 VALID UNTIL: 3/20/2026

ORDER ACCEPTANCE

SIGNATURE

DATE

ADDITIONAL OPTIONS: Prices shown in "additional options available" section are not included in the "Total" price and do not include taxes.

TAXES: Unless itemized above, prices do not include local, state or federal taxes.

MOTOR VEHICLE TAXES: AECI no longer collects SC "IMF" or NC "Highway Use Tax". Either the chassis dealer or the DMV will collect motor vehicle tax/fees when registering vehicle.

PAYMENT TERMS: Payment is due PRIOR to delivery. When ample credit has been extended to customer, payment is due within 30 Days of invoice.

TITLEWORK / MCO: Allow 5-10 business days after receipt of payment to process Title or Manufacturer's Certificate of Origin (MCO).

QUOTE EXPIRATION: Pricing is honored for 30 days from date quoted, barring extenuating circumstances such as, but not limited to, volatile markets, factory price increases, etc. AECI makes every effort to give as much notice as possible in such instances.

DELIVERY ESTIMATES: ETA's are based on production schedules at the time of quote and are subject to changes in truck or body production schedules as well other factors such as transportation delays, etc.

WEIGHT RESTRICTIONS: Operating overweight equipment can result in fines, damage to equipment or injury to operators. AECI makes every effort to quote equipment meeting local, state & federal weight regulations. Nevertheless, it is up to the end user to familiarize themselves with all applicable weight laws and avoid exceeding legal weight limits, regardless of truck's GVWR.

CHASSIS DEALERS: Please ensure chassis specs meet body manufacturer's minimum requirements, which are supplied upon request. Deviations may result in additional charges, for which the truck dealer will be responsible.

CHASSIS DEALER PAYMENT TERMS: Payment term begins when truck is delivered to customer or truck dealer for PDI, whichever is first. Payments received later than 15 DAYS are subject to penalty of Prime % APR, calculated on a daily basis. ANY EXCEPTIONS must be agreed to writing prior to order.

COOPERATIVE PURCHASING CONTRACTS: Cooperative purchasing contract such as NCSA, Sourcewell, etc. are a tool which satisfies the competitive bidding requirements for some municipalities. Amick Equipment (or its Body Manufacturer) are approved vendors on several contracts, authorized to offer awarded equipment according to each contract's terms and conditions. If a contract award included both body and chassis, then that contract clearly satisfies the bidding requirements for both body and chassis. Some of Amick's contracts were awarded for the body portion only. Upon request, Amick may offer a compatible chassis from another qualified contract holder or may offer a non-contract option.. Unless explicitly stated, customers shall not assume that any of

SIDEWINDER XTR™ S E R I E S



TRACTION IN ANY ENVIRONMENT

With the New Way® Sidewinder XTR™ Automated Side Loader, efficiency is always at your side. Enjoy smooth one-operator convenience and a faster compaction rate than any other side loader on the market. Combine the strongest frame-mounted arm in the industry—boasting a 12-foot reach—with the convenience of automated loading and the ability to maneuver in tight spaces and you have an agile, ultra-tough, overbuilt loader.



GENERAL SPECIFICATIONS

Model	22 A	24 A	29 A	31 A	31XL	33YD ³
Body Capacity	22 yd ³	24 yd ³	29 yd ³	31 yd ³	31 yd ³	31 yd ³
Body Width (A)	96"	96"	96"	96"	96"	96"
Body Height (B)	108"	108"	108"	108"	108"	108"
Body Length (C)	237"	247"	286"	297"	305"	316"
†Raised Tailgate Height	213.5"	213.5"	213.5"	213.5"	213.5"	213.5"
†Body Height (Raised)	195"	195"	229"	229"	273.5"	273.5"

MINIMUM CHASSIS SPECIFICATIONS

Model	22 A	24 A	29 A	31 A	31XL	33
*Minimum GVWR	46,000 lbs	46,000 lbs	64,000 lbs	64,000 lbs	64,000 lbs	64,000 lbs
Cab to Trunnion	160"	160"	194"	194"	218"-226"	218"-226"

ALSO AVAILABLE IN 18 AND 20 YD³ MODELS

PACKER SPECIFICATIONS

Hopper Capacity	6 yd ³
Packer Swept Volume	2 yd ³
Packer Cycle Time	21 secs.
Ram Penetration	8.5"
Ram Compaction Force	75,000 lbs @ 3,000 psi

ARM SPECIFICATIONS

Arm Extension	144"
** Arm Lifting Capacity	Up to 1,000 lbs
Horizontal Mast Bearings	6
Arm Cycle Time	6-8 secs.

BODY CONSTRUCTION

Roof	10 gauge	80K
Sides	1/8"	AR450
Packer Panel	1/4"	AR450
Body Floor	3/16"	AR450
Tailgate Back	1/8"	AR450
Tailgate Sides	10 gauge	80K
Hopper Floor/Sides	1/4"	AR450
Ram Guide	3/8" x 3"	AR400 wear strips top 1/4" sides

† As measured from top of truck frame.

* Any Chassis sent to Scranton Manufacturing with less than the minimum guideline requirements will not be mounted.

(Chassis must be capable of carrying the net weight of the body plus the weight of the refuse collected.)

** May require optional equipment.

HYDRAULIC SYSTEM

Oil Reservoir	70 gal
Oil Flow Rate	
Body	20 gpm @ 750 RPM
Arm	18 gpm @ 750 RPM

Body Operating Pressure

22-24 yd ³ units	2,500 psi
29-31 yd ³ units	3,000 psi

Arm Operating Pressure

2,000 psi

Hoses 4-to-1 burst

Return Filters Dual in-tank 10 micron absolute

HYDRAULIC CYLINDER SPECIFICATIONS

Tailgate Cylinders	3" x 30" x 2"
Pack Panel Cylinders	4" x 43" x 2.5"
Gripper Cylinder	1.5" x 5" x 1"
Vertical Lift Cylinder	3" x 16" x 2"
Body Hoist Cylinder	
	22-24 yd ³ 6.5" x 150" 4-Stage
	29-31 yd ³ 6.5" x 180" 4-Stage
Horizontal Mast Cylinder	2" x 54" x 1.25"
Hopper Cover Cylinder	2" x 18" x 1.25"

STANDARD EQUIPMENT

- Pack-on-the-Go
- Twin 14.5" x 7" clean out doors
- Chrome cylinder rods w/scrapers
- Interlocked side access hopper door
- Nitro carbonite single-hoist cylinder
- Sight gauge on reservoir tank
- Tailgate ajar alarm
- Imron elite productive paint
- High-grade hydraulic fluid
- Dual camera system
- Reinforced frame-mounted arm
- In-line heavy duty grippers
- Sealed roller bearings on packer follower panels
- Ergonomic in-cab control panel and joystick
- Smooth body sidewall design
- Positive automatic tailgate lock
- Back-up alarm
- Body ajar alarm
- Hour meter
- "Arm stowed" indicator
- LED lights
- ANSI Z245.1-2017 compliant
- Multi-cycle packer
- Home position arm lock
- Fold-up valve door

OPTIONAL EQUIPMENT

- Hydraulic hopper cover
- 300 gallon gripper
- Camera options
- Additional arm controls
- Hopper ladder
- Broom/shovel racks
- Arm cycle counter
- CNG powered
- West Coast/Lightweight model also available (1,500 lbs reduction)
- Choice of control systems:
 - Air over hydraulic controls
 - CAN bus controls for in-cab diagnostics
- In-cab adjustable gripper pressure

AUTHORIZED NEW WAY DISTRIBUTOR



Sourcewell
Formerly NAPA
Awarded Contract
Contract # 091219-NWY

NEW WAY Driving The Difference.®

a quality product of McLaughlin FAMILY COMPANIES • 800 831 1858 • www.newwaytrucks.com

Prepared for:
 SCRANTON MFG CO INC BB
 101 STATE ST
 SCRANTON, IA 51462
 Phone: 712-652-3396

Prepared by:
 A j Mccaffrey
 I-STATE TRUCK CENTER
 4801 HARBOR DRIVE
 SIOUX CITY, IA 51111
 Phone: 712-252-2714
 E-Mail:
 Aj.McCaffrey@istatetruck.com

S P E C I F I C A T I O N P R O P O S A L

Description	Weight Front	Weight Rear
Price Level		
M2 PRL-29M (EFF:MY26 ORDERS)		
Data Version		
SPECPRO21 DATA RELEASE VER 019		
Bright Work Packages		
BRIGHT WORK PACKAGE 1 - CHROMED: AIR INTAKE, GRILLE, HEADLIGHT BEZEL AND 14 INCH ROUND POLISHED AIR HORN		
Vehicle Configuration		
M2 106 PLUS CONVENTIONAL CHASSIS 2026 MODEL YEAR SPECIFIED SET BACK AXLE - TRUCK STRAIGHT TRUCK PROVISION, NON-TOWING LH PRIMARY STEERING LOCATION AND PREP FOR CUSTOMER SUPPLIED RH SIT-DOWN SECONDARY STEERING LOCATION WITH DUAL INSTRUMENT CLUSTER	5,709	3,450
General Service		
TRUCK CONFIGURATION DOMICILED, USA (EXCLUDING CALIFORNIA AND CARB OPT-IN STATES) EPA CLEAN IDLE LABEL FOR INITIAL REGISTRATION IN EPA OR ACT STATES - (INCLUDES 6X4 INCH LABEL ON LOWER FORWARD OF DRIVER DOOR) NONE REFUSE SERVICE SANITATION BUSINESS SEGMENT MOIST BULK COMMODITY TERRAIN/DUTY: 100% (ALL) OF THE TIME, IN TRANSIT, IS SPENT ON PAVED ROADS MAXIMUM 8% EXPECTED GRADE		



Prepared for:
 SCRANTON MFG CO INC BB
 101 STATE ST
 SCRANTON, IA 51462
 Phone: 712-652-3396

Prepared by:
 A j Mccaffrey
 I-STATE TRUCK CENTER
 4801 HARBOR DRIVE
 SIOUX CITY, IA 51111
 Phone: 712-252-2714
 E-Mail:
 Aj.McCaffrey@istatetruck.com

Description	Weight Front	Weight Rear
SMOOTH CONCRETE OR ASPHALT PAVEMENT - MOST SEVERE IN-TRANSIT (BETWEEN SITES) ROAD SURFACE		
MEDIUM TRUCK WARRANTY		
EXPECTED FRONT AXLE(S) LOAD : 18000.0 lbs		
EXPECTED REAR DRIVE AXLE(S) LOAD : 44000.0 lbs		
EXPECTED GROSS VEHICLE WEIGHT CAPACITY : 62000.0 lbs		

Truck Service

REFUSE, SIDE LOAD OR REAR PACKER BODY - UNLOADS IN A LANDFILL
 SCRANTON MANUFACTURING/NEW WAY
 EXPECTED BODY/PAYLOAD CG HEIGHT ABOVE FRAME "XX" INCHES : 32.0 in

Engine

CUM L9 360 HP @ 2200 RPM, 2200 GOV RPM, 1150 LB-FT @ 1200 RPM, REFUSE	640	30
---	-----	----

Electronic Parameters

67 MPH ROAD SPEED LIMIT
 CRUISE CONTROL SPEED LIMIT SAME AS ROAD SPEED LIMIT
 PTO MODE ENGINE RPM LIMIT - 1400 RPM
 PTO MODE THROTTLE OVERRIDE - LIMIT TO 1400 RPM
 PTO MODE BRAKE OVERRIDE - SERVICE BRAKE APPLIED
 PTO RPM WITH CRUISE SET SWITCH - 1200 RPM
 PTO RPM WITH CRUISE RESUME SWITCH - 1400 RPM
 PTO MODE CANCEL VEHICLE SPEED - 5 MPH
 PTO GOVERNOR RAMP RATE - 1000 RPM PER SECOND
 CRUISE CONTROL BUTTON PTO CONTROL AND THREE REMOTE PTO SPEEDS
 PTO SPEED 1 SETTING - 1200 RPM
 PTO SPEED 2 SETTING - 1300 RPM
 PTO SPEED 3 SETTING - 600 RPM
 PTO MINIMUM RPM - 700
 REGEN INHIBIT SPEED THRESHOLD - 5 MPH



Prepared for:
 SCRANTON MFG CO INC BB
 101 STATE ST
 SCRANTON, IA 51462
 Phone: 712-652-3396

Prepared by:
 A j Mccaffrey
 I-STATE TRUCK CENTER
 4801 HARBOR DRIVE
 SIOUX CITY, IA 51111
 Phone: 712-252-2714
 E-Mail:
 Aj.McCaffrey@istatetruck.com

Description	Weight Front	Weight Rear
PTO 1, WITH SWITCH, TEM SUPPLIED REQUEST AND INTERLOCKS, WITH PTO CONNECTIONS, NO FACTORY INTERLOCKS		
Engine Equipment		
EPA 2010/GHG 2024 CONFIGURATION		
NO CARB24 SURCHARGE		
STANDARD OIL PAN		
ENGINE MOUNTED OIL CHECK AND FILL		
SIDE OF HOOD AIR INTAKE WITH DONALDSON HIGH CAPACITY AIR CLEANER WITH SAFETY ELEMENT, FIREWALL MOUNTED		
DR 12V 160 AMP 28-SI QUADRAMOUNT PAD ALTERNATOR WITH REMOTE BATTERY VOLT SENSE		
(2) DTNA GENUINE, FLOODED STARTING, MIN 2000CCA, 370RC, THREADED STUD BATTERIES	10	
BATTERY BOX WITH ALUMINUM COVER MOUNTED SHORT SIDE TO RAIL		
STANDARD BATTERY JUMPERS		
SINGLE BATTERY BOX FRAME MOUNTED LH SIDE BACK OF CAB		
WIRE GROUND RETURN FOR BATTERY CABLES WITH ADDITIONAL FRAME GROUND RETURN		
NON-POLISHED BATTERY BOX COVER		
NON-ESSENTIAL POSITIVE LOAD DISCONNECT, IN CAB CONTROL SWITCH MOUNTED OUTBOARD OF DRIVER SEAT	2	
POSITIVE AND NEGATIVE POSTS FOR JUMPSTART LOCATED ON FRAME NEXT TO STARTER	2	
PROGRESSIVE LOW VOLTAGE DISCONNECT AT 12.3 VOLTS FOR DESIGNATED CIRCUITS	2	
CUMMINS TURBOCHARGED 18.7 CFM AIR COMPRESSOR WITH INTERNAL SAFETY VALVE		
STANDARD MECHANICAL AIR COMPRESSOR GOVERNOR		
AIR COMPRESSOR DISCHARGE LINE		
ELECTRONIC ENGINE INTEGRAL SHUTDOWN PROTECTION SYSTEM		
CUMMINS ENGINE INTEGRAL BRAKE WITH VARIABLE GEOMETRY TURBO ON/OFF	20	
RH OUTBOARD UNDER STEP MOUNTED HORIZONTAL AFTERTREATMENT SYSTEM ASSEMBLY WITH LH B-PILLAR MOUNTED VERTICAL TAILPIPE	35	35



Prepared for:
 SCRANTON MFG CO INC BB
 101 STATE ST
 SCRANTON, IA 51462
 Phone: 712-652-3396

Prepared by:
 A j Mccaffrey
 I-STATE TRUCK CENTER
 4801 HARBOR DRIVE
 SIOUX CITY, IA 51111
 Phone: 712-252-2714
 E-Mail:
 Aj.McCaffrey@istatetruck.com

Description	Weight Front	Weight Rear
ENGINE AFTERTREATMENT DEVICE, AUTOMATIC OVER THE ROAD REGENERATION AND VIRTUAL REGENERATION REQUEST SWITCH IN CLUSTER		
11 FOOT 06 INCH (138 INCH+0/-5.9 INCH) EXHAUST SYSTEM HEIGHT		
STANDARD CURVE BRIGHT UPPER STACK(S)		
LH CURVED VERTICAL TAILPIPE B-PILLAR MOUNTED ROUTED OVER FRAME		
13 GALLON DIESEL EXHAUST FLUID TANK	35	10
100 PERCENT DIESEL EXHAUST FLUID FILL		
POLISHED ALUMINUM DIAMOND PLATE DIESEL EXHAUST FLUID TANK COVER	15	5
LH MEDIUM DUTY STANDARD DIESEL EXHAUST FLUID TANK LOCATION		
STANDARD DIESEL EXHAUST FLUID PUMP MOUNTING		
STANDARD DIESEL EXHAUST FLUID TANK CAP		
STAINLESS STEEL AFTERTREATMENT DEVICE/MUFFLER/TAILOPIPE SHIELD		
AIR POWERED ON/OFF ENGINE FAN CLUTCH		
AUTOMATIC FAN CONTROL WITHOUT DASH SWITCH, NON ENGINE MOUNTED		
CUMMINS SPIN ON FUEL FILTER		
COMBINATION FULL FLOW/BYPASS OIL FILTER		
NO COOLANT FILTER	-10	
1100 SQUARE INCH ALUMINUM RADIATOR	70	
ANTIFREEZE TO -34F, OAT (NITRITE AND SILICATE FREE) EXTENDED LIFE COOLANT		
GATES BLUE STRIPE COOLANT HOSES OR EQUIVALENT		
CONSTANT TENSION HOSE CLAMPS FOR COOLANT HOSES		
RADIATOR DRAIN VALVE		
LOWER RADIATOR GUARD		
PHILLIPS-TEMRO 1000 WATT/115 VOLT BLOCK HEATER	4	
CHROME ENGINE HEATER RECEPTACLE MOUNTED UNDER LH DOOR		
ALUMINUM FLYWHEEL HOUSING		
ELECTRIC GRID AIR INTAKE WARMER		
DELCO 12V 39MT HD/OCP STARTER WITH THERMAL PROTECTION AND INTEGRATED MAGNETIC SWITCH	15	



Prepared for:
 SCRANTON MFG CO INC BB
 101 STATE ST
 SCRANTON, IA 51462
 Phone: 712-652-3396

Prepared by:
 A j Mccaffrey
 I-STATE TRUCK CENTER
 4801 HARBOR DRIVE
 SIOUX CITY, IA 51111
 Phone: 712-252-2714
 E-Mail:
 Aj.McCaffrey@istatetruck.com

Description	Weight Front	Weight Rear
Transmission		
ALLISON 3000 RDS AUTOMATIC TRANSMISSION WITH PTO PROVISION	200	60

Transmission Equipment		
ALLISON VOCATIONAL PACKAGE 142 - AVAILABLE ON 3000/4000 PRODUCT FAMILIES WITH VOCATIONAL MODEL RDS		
ALLISON VOCATIONAL RATING FOR REFUSE APPLICATIONS AVAILABLE WITH ALL PRODUCT FAMILIES		
PRIMARY MODE GEARS, LOWEST GEAR 1, START GEAR 1, HIGHEST GEAR 6, AVAILABLE FOR 3000/4000 PRODUCT FAMILIES ONLY		
SECONDARY MODE GEARS, LOWEST GEAR 1, START GEAR 1, HIGHEST GEAR 6, AVAILABLE FOR 3000/4000 PRODUCT FAMILIES ONLY		
S1 PERFORMANCE PRIMARY SHIFT SCHEDULE, AVAILABLE FOR 3000/4000 PRODUCT FAMILIES ONLY		
S1 PERFORMANCE SECONDARY SHIFT SCHEDULE, AVAILABLE FOR 3000/4000 PRODUCT FAMILIES ONLY		
2000 RPM PRIMARY MODE SHIFT SPEED		
2000 RPM SECONDARY MODE SHIFT SPEED		
ENGINE BRAKE RANGE PRESELECT RECOMMENDED BY DTNA AND ALLISON, THIS DEFINED BY ENGINE AND VOCATIONAL USAGE		
ENGINE BRAKE RANGE ALTERNATE PRESELECT RECOMMENDED BY DTNA AND ALLISON, THIS DEFINED BY ENGINE AND VOCATIONAL USAGE		
FUEL SENSE 2.0 PLUS - DYNACTIVE: PERFORMANCE, NEUTRAL AT STOP: ACTIVE		
DRIVER SWITCH INPUT - DEFAULT - NO SWITCHES		
QUICKFIT BODY LIGHTING CONNECTOR UNDER CAB, WITHOUT CAP		
ELECTRONIC TRANSMISSION WIRING TO CUSTOMER INTERFACE CONNECTOR		
CUSTOMER INSTALLED CHELSEA 280 SERIES PTO		
PTO MOUNTING, LH SIDE OF MAIN TRANSMISSION ALLISON		
MAGNETIC PLUGS, ENGINE DRAIN, TRANSMISSION DRAIN, AXLE(S) FILL AND DRAIN		



Prepared for:
 SCRANTON MFG CO INC BB
 101 STATE ST
 SCRANTON, IA 51462
 Phone: 712-652-3396

Prepared by:
 A j Mccaffrey
 I-STATE TRUCK CENTER
 4801 HARBOR DRIVE
 SIOUX CITY, IA 51111
 Phone: 712-252-2714
 E-Mail:
 Aj.McCaffrey@istatetruck.com

Description	Weight Front	Weight Rear
PUSH BUTTON ELECTRONIC SHIFT CONTROL, DASH MOUNTED		
TRANSMISSION PROGNOSTICS - ENABLED 2013		
WATER TO OIL TRANSMISSION COOLER, IN RADIATOR END TANK	15	
TRANSMISSION OIL CHECK AND FILL WITH ELECTRONIC OIL LEVEL CHECK		
SYNTHETIC TRANSMISSION FLUID (TES-295 COMPLIANT)		

Front Axle and Equipment

DETROIT DA-F-18.0-5 18,000# FL1 71.0 KPI/3.74 DROP SINGLE FRONT AXLE	210	
MERITOR 16.5X6 Q+ CAST SPIDER HEAVY DUTY CAM FRONT BRAKES, DOUBLE ANCHOR, FABRICATED SHOES		
NON-ASBESTOS FRONT BRAKE LINING		
CONMET CAST IRON FRONT BRAKE DRUMS		
FRONT BRAKE DUST SHIELDS	5	
FRONT OIL SEALS		
VENTED FRONT HUB CAPS WITH WINDOW, CENTER AND SIDE PLUGS - OIL		
STANDARD SPINDLE NUTS FOR ALL AXLES		
MERITOR AUTOMATIC FRONT SLACK ADJUSTERS		
TRW TAS-85 POWER STEERING	40	
POWER STEERING PUMP		
2 QUART SEE THROUGH POWER STEERING RESERVOIR		
OIL/AIR POWER STEERING COOLER	5	
CURRENT AVAILABLE SYNTHETIC 75W-90 FRONT AXLE LUBE		

Front Suspension

20,000# TAPERLEAF FRONT SUSPENSION	200	
MAINTENANCE FREE RUBBER BUSHINGS - FRONT SUSPENSION		
FRONT SHOCK ABSORBERS		

Rear Axle and Equipment

MERITOR RT-46-160P 46,000# R-SERIES TANDEM REAR AXLE WITH PUMP		2,990
6.14 REAR AXLE RATIO		
IRON REAR AXLE CARRIER WITH STANDARD AXLE HOUSING		



Prepared for:
 SCRANTON MFG CO INC BB
 101 STATE ST
 SCRANTON, IA 51462
 Phone: 712-652-3396

Prepared by:
 A j Mccaffrey
 I-STATE TRUCK CENTER
 4801 HARBOR DRIVE
 SIOUX CITY, IA 51111
 Phone: 712-252-2714
 E-Mail:
 Aj.McCaffrey@istatetruck.com

Description	Weight Front	Weight Rear
MXL 17T MERITOR EXTENDED LUBE MAIN DRIVELINE WITH HALF ROUND YOKES	40	40
MXL 17T MERITOR EXTENDED LUBE INTERAXLE DRIVELINE WITH HALF ROUND YOKES		
DRIVER CONTROLLED TRACTION DIFFERENTIAL - BOTH TANDEM REAR AXLES		30
(1) INTERAXLE LOCK VALVE, (1) DRIVER CONTROLLED DIFFERENTIAL LOCK FORWARD-REAR AND REAR-REAR AXLE VALVE		
INDICATOR LIGHT FOR EACH INTERAXLE LOCKOUT SWITCH, DISENGAGE INTERAXLE LOCK WITH IGNITION OFF		
INDICATOR LIGHT FOR EACH DIFFERENTIAL LOCKOUT SWITCH, ENGAGE AT SPEEDS 5MPH OR LESS, DISENGAGE W/IGN OFF		
MERITOR 16.5X8.62 Q+ CAST SPIDER HEAVY DUTY CAM REAR BRAKES, DOUBLE ANCHOR, FABRICATED SHOES		
NON-ASBESTOS REAR BRAKE LINING		
BRAKE CAMS AND CHAMBERS ON FORWARD SIDE OF DRIVE AXLE(S)		
CONMET CAST IRON REAR BRAKE DRUMS		
REAR BRAKE DUST SHIELDS		10
REAR OIL SEALS		
BENDIX EVERSURE LONGSTROKE 2-DRIVE AXLES SPRING PARKING CHAMBERS		20
HALDEX AUTOMATIC REAR SLACK ADJUSTERS		
CURRENT AVAILABLE SYNTHETIC 75W-90 REAR AXLE LUBE		

Rear Suspension

TUFTRAC GEN2 46,000# REAR SPRING SUSPENSION		820
9.5 INCH NOMINAL RIDE HEIGHT (460MM GLOBAL REFERENCE HEIGHT)		
AXLE CLAMPING GROUP		
55 INCH AXLE SPACING		
FORE/AFT AND TRANSVERSE CONTROL RODS		
REAR SHOCK ABSORBERS - TWO AXLES (TANDEM)		40

Pusher / Tag Equipment

NO PUSHER/TAG BRAKE DUST SHIELDS

Brake System

AIR BRAKE PACKAGE



Prepared for:
 SCRANTON MFG CO INC BB
 101 STATE ST
 SCRANTON, IA 51462
 Phone: 712-652-3396

Prepared by:
 A j Mccaffrey
 I-STATE TRUCK CENTER
 4801 HARBOR DRIVE
 SIOUX CITY, IA 51111
 Phone: 712-252-2714
 E-Mail:
 Aj.McCaffrey@istatetruck.com

Description	Weight Front	Weight Rear
WABCO 4S/4M ABS		
REINFORCED NYLON, FABRIC BRAID AND WIRE BRAID CHASSIS AIR LINES		
FIBER BRAID PARKING BRAKE HOSE		
STANDARD BRAKE SYSTEM VALVES		
STANDARD AIR SYSTEM PRESSURE PROTECTION SYSTEM		
STD U.S. FRONT BRAKE VALVE		
RELAY VALVE WITH 5-8 PSI CRACK PRESSURE, NO REAR PROPORTIONING VALVE		
BW AD-9SI BRAKE LINE AIR DRYER WITH HEATER		
AIR DRYER MOUNTED INBOARD ON LH RAIL		
STEEL AIR BRAKE RESERVOIRS		
PULL CABLES ON ALL AIR RESERVOIR(S)		
Trailer Connections		
NO TRAILER AIR HOSE		
NO AIR HOSE HANGER		
NO TRAILER ELECTRICAL CABLE		
Wheelbase & Frame		
6775MM (267 INCH) WHEELBASE		
11/32X3-1/2X10-15/16 INCH STEEL FRAME (8.73MMX277.8MM/0.344X10.94 INCH) 120KSI	430	150
1/4 INCH (6.35MM) C-CHANNEL INNER FRAME REINFORCEMENT	220	430
1825MM (72 INCH) REAR FRAME OVERHANG		
FRAME OVERHANG RANGE: 71 INCH TO 80 INCH	-30	120
CALC'D BACK OF CAB TO REAR SUSP C/L (CA) : 201.18 in		
CALCULATED EFFECTIVE BACK OF CAB TO REAR SUSPENSION C/L (CA) : 198.18 in		
CALC'D FRAME LENGTH - OVERALL : 368.02 in		
CALCULATED FRAME SPACE LH SIDE : 92.72 in		
CALCULATED FRAME SPACE RH SIDE : 146.73 in		
CALC'D SPACE AVAILABLE FOR DECKPLATE : 0.0 in		
SQUARE END OF FRAME		
FRONT CLOSING CROSSMEMBER		
LIGHTWEIGHT HEAVY DUTY ALUMINUM ENGINE CROSSMEMBER	-12	



Prepared for:
 SCRANTON MFG CO INC BB
 101 STATE ST
 SCRANTON, IA 51462
 Phone: 712-652-3396

Prepared by:
 A j Mccaffrey
 I-STATE TRUCK CENTER
 4801 HARBOR DRIVE
 SIOUX CITY, IA 51111
 Phone: 712-252-2714
 E-Mail:
 Aj.McCaffrey@istatetruck.com

Description	Weight Front	Weight Rear
STANDARD CROSSMEMBER BACK OF TRANSMISSION		
STANDARD MIDSHIP #1 CROSSMEMBER(S)		
STANDARD REAR MOST CROSSMEMBER		
HEAVY DUTY SUSPENSION CROSSMEMBER		30
Chassis Equipment		
THREE-PIECE 14 INCH CHROMED STEEL BUMPER WITH COLLAPSIBLE ENDS	30	
FRONT TOW HOOKS - FRAME MOUNTED	15	
BUMPER MOUNTING FOR SINGLE LICENSE PLATE		
NO MUDFLAP BRACKETS		
NO REAR MUDFLAPS		
FENDER AND FRONT OF HOOD MOUNTED FRONT MUDFLAPS		
GRADE 8 THREADED HEX HEADED FRAME FASTENERS		
EXTERIOR HARNESSSES WRAPPED IN ABRASION TAPE		
CLEAR FRAME RAILS FROM BACK OF CAB TO FRONT REAR SUSPENSION BRACKET, BOTH RAILS OUTBOARD		
Fifth Wheel		
NO FIFTH WHEEL		
Fuel Tanks		
80 GALLON/302 LITER RECTANGULAR ALUMINUM FUEL TANK - LH	40	10
RECTANGULAR FUEL TANK(S)		
PLAIN ALUMINUM/PAINTED STEEL FUEL/HYDRAULIC TANK(S) WITH PAINTED BANDS		
FUEL TANK(S) FORWARD		
10 GALLONS ADDITIONAL FUEL		
PLAIN STEP FINISH		
FUEL TANK CAP(S)		
DETROIT FUEL/WATER SEPARATOR WITH WATER IN FUEL SENSOR, HAND PRIMER AND 12 VOLT PREHEATER"	-5	
EQUIFLO INBOARD FUEL SYSTEM		
HIGH TEMPERATURE REINFORCED NYLON FUEL LINE		
Tires		



Prepared for:
 SCRANTON MFG CO INC BB
 101 STATE ST
 SCRANTON, IA 51462
 Phone: 712-652-3396

Prepared by:
 A j Mccaffrey
 I-STATE TRUCK CENTER
 4801 HARBOR DRIVE
 SIOUX CITY, IA 51111
 Phone: 712-252-2714
 E-Mail:
 Aj.McCaffrey@istatetruck.com

Description	Weight Front	Weight Rear
MICHELIN X WORKS Z 315/80R22.5 20 PLY RADIAL FRONT TIRES	100	
MICHELIN X MULTI D+ 11R22.5 16 PLY RADIAL REAR TIRES		120

Hubs

CONMET PRESET PLUS PREMIUM IRON FRONT HUBS
 CONMET PRESET PLUS PREMIUM IRON REAR HUBS

Wheels

ALCOA ULTRA ONE 89U64X 22.5X9.00 10-HUB PILOT 5.99 INSET ALUMINUM FRONT WHEELS -28
 ALCOA ULA18X 22.5X8.25 10-HUB PILOT ALUMINUM DISC REAR WHEELS -248
 POLISHED FRONT WHEELS; OUTSIDE ONLY
 POLISHED REAR WHEELS; OUTSIDE OF OUTER WHEELS ONLY
 FRONT WHEEL MOUNTING NUTS
 REAR WHEEL MOUNTING NUTS

Cab Exterior

106 INCH BBC FLAT ROOF ALUMINUM CONVENTIONAL CAB
 AIR CAB MOUNTING
 NONREMOVABLE BUGSCREEN MOUNTED BEHIND GRILLE
 2-1/2 INCH FENDER EXTENSIONS 10
 LH AND RH GRAB HANDLES
 HOOD MOUNTED CHROMED PLASTIC GRILLE
 CHROME HOOD MOUNTED AIR INTAKE GRILLE
 FIBERGLASS HOOD
 TUNNEL/FIREWALL LINER
 DUAL 26 INCH RECTANGULAR POLISHED ALUMINUM AIR HORNS ROOF MOUNTED 8
 SINGLE ELECTRIC HORN
 DUAL HORN SHIELDS
 REAR LICENSE PLATE MOUNT END OF FRAME
 LED HEADLIGHT ASSEMBLY AND INCANDESCENT MARKER/TURN LAMP WITH CHROME BEZEL
 LED AERODYNAMIC MARKER LIGHTS
 DAYTIME RUNNING LIGHTS



Prepared for:
 SCRANTON MFG CO INC BB
 101 STATE ST
 SCRANTON, IA 51462
 Phone: 712-652-3396

Prepared by:
 A j Mccaffrey
 I-STATE TRUCK CENTER
 4801 HARBOR DRIVE
 SIOUX CITY, IA 51111
 Phone: 712-252-2714
 E-Mail:
 Aj.McCaffrey@istatetruck.com

Description	Weight Front	Weight Rear
OMIT STOP/TAIL/BACKUP LIGHTS AND PROVIDE WIRING WITH SEPARATE STOP/TURN WIRES TO 4 FEET BEYOND END OF FRAME		-5
STANDARD FRONT TURN SIGNAL LAMPS		
DUAL WEST COAST BRIGHT FINISH HEATED MIRRORS WITH LED LIGHTS AND LH AND RH REMOTE		
DOOR MOUNTED MIRRORS		
102 INCH EQUIPMENT WIDTH		
LH AND RH 8 INCH BRIGHT FINISH CONVEX MIRRORS MOUNTED UNDER PRIMARY MIRRORS		
RH AND LH 8 INCH STAINLESS STEEL FENDER MOUNTED CONVEX MIRRORS WITH TRIPOD BRACKETS	8	
STANDARD SIDE/REAR REFLECTORS		
RH AFTERTREATMENT SYSTEM CAB ACCESS WITH POLISHED DIAMOND PLATE COVER		
PARK BRAKE REMINDER WARNING SYSTEM		
COMPOSITE EXTERIOR SUN VISOR	10	
63X14 INCH TINTED REAR WINDOW		
TINTED DOOR GLASS LH AND RH WITH TINTED NON-OPERATING WING WINDOWS		
RH AND LH ELECTRIC POWERED WINDOWS		
1-PIECE SOLAR GREEN GLASS WINDSHIELD		
1.5 GALLON WINDSHIELD WASHER RESERVOIR RH FRAME MOUNTED BEHIND RADIATOR		
WHITE WINTERFRONT	2	

Cab Interior

PROFESSIONAL TRIM PACKAGE
 MIST AND CARBON CLOTH INTERIOR "PROFESSIONAL"
 CARBON WITH BASE BLACK ACCENT
 MOLDED PLASTIC DOOR PANEL
 MOLDED PLASTIC DOOR PANEL
 BLACK MATS WITH SINGLE INSULATION
 (1)DASH MOUNTED 12V POWER OUTLET,
 (1)DASH MOUNTED DUAL USB-C OUTLET
 FORWARD ROOF MOUNTED CONSOLE
 LH AND RH DOOR STORAGE POCKETS INTEGRATED INTO MOLDED DOOR PANELS
 DIGITAL ALARM CLOCK IN DRIVER DISPLAY
 (2) CUP HOLDERS LH AND RH DASH



Prepared for:
 SCRANTON MFG CO INC BB
 101 STATE ST
 SCRANTON, IA 51462
 Phone: 712-652-3396

Prepared by:
 A j Mccaffrey
 I-STATE TRUCK CENTER
 4801 HARBOR DRIVE
 SIOUX CITY, IA 51111
 Phone: 712-252-2714
 E-Mail:
 Aj.McCaffrey@istatetruck.com

Description	Weight Front	Weight Rear
M2/SD DASH		
HEATER, DEFROSTER AND AIR CONDITIONER		
STANDARD HVAC DUCTING		
MAIN HVAC CONTROLS WITH RECIRCULATION SWITCH		
STANDARD HEATER PLUMBING WITH BALL SHUTOFF VALVES AT SUPPLY LINES ONLY		
VALEO HEAVY DUTY A/C REFRIGERANT COMPRESSOR		
BINARY CONTROL, R-134A		
PREMIUM INSULATION		
SOLID-STATE CIRCUIT PROTECTION AND FUSES		
12V NEGATIVE GROUND ELECTRICAL SYSTEM		
PREMIUM LED CAB LIGHTING		
REMOTE KEYLESS ENTRY AND 2 TRANSMITTERS	2	
DOOR LOCKS AND IGNITION SWITCH KEYED THE SAME		
KEY QUANTITY OF 2		
LH AND RH ELECTRIC DOOR LOCKS		
NO MATTRESS	-20	-15
BASIC ISRINGHAUSEN HIGH BACK AIR SUSPENSION DRIVERS SEAT WITH MECHANICAL LUMBAR AND INTEGRATED CUSHION EXTENSION	30	
BASIC ISRINGHAUSEN HIGH BACK AIR SUSPENSION PASSENGER SEAT WITH MECHANICAL LUMBAR AND INTEGRATED CUSHION EXTENSION	25	10
INBOARD DRIVER AND PASSENGER SEAT ARMRESTS	4	
LH AND RH INTEGRAL DOOR PANEL ARMRESTS		
BLACK CORDURA PLUS CLOTH DRIVER SEAT COVER		
BLACK CORDURA PLUS CLOTH PASSENGER SEAT COVER		
BLACK SEAT BELTS		
ADJUSTABLE STEERING COLUMN, SUPPLIER CONVERSION TO LH AND RH ADJUSTABLE TILT STEERING COLUMNS	10	
4-SPOKE 18 INCH (450MM) BLACK STEERING WHEEL WITH SWITCHES		



Prepared for:
 SCRANTON MFG CO INC BB
 101 STATE ST
 SCRANTON, IA 51462
 Phone: 712-652-3396

Prepared by:
 A j Mccaffrey
 I-STATE TRUCK CENTER
 4801 HARBOR DRIVE
 SIOUX CITY, IA 51111
 Phone: 712-252-2714
 E-Mail:
 Aj.McCaffrey@istatetruck.com

Description	Weight Front	Weight Rear
DRIVER AND PASSENGER INTERIOR SUN VISORS		
Instruments & Controls		
ELECTRONIC ACCELERATOR CONTROL		
NO INSTRUMENT PANEL-DRIVER		
FULLY CONFIGURABLE CENTER INSTRUMENT PANELS		
ENGINE REMOTE INTERFACE WITHOUT INTERLOCKS		
BLACK GAUGE BEZELS		
LOW AIR PRESSURE INDICATOR LIGHT AND AUDIBLE ALARM		
DUAL NEEDLE PRIMARY AND SECONDARY AIR PRESSURE GAUGE		
ELECTRONIC AIR RESTRICTION INDICATOR DISPLAYED IN DRIVER DISPLAY		
ELECTRONIC CRUISE CONTROL WITH CONTROLS ON STEERING WHEEL SPOKES		
KEY OPERATED IGNITION SWITCH AND INTEGRAL START POSITION; 4 POSITION OFF/RUN/START/ACCESSORY		
PREMIUM INSTRUMENT CLUSTER WITH 5.0 INCH TFT COLOR DISPLAY		
DIGITAL PANEL LAMP DIMMER SWITCH IN DRIVER DISPLAY		
HEAVY DUTY ONBOARD DIAGNOSTICS INTERFACE CONNECTOR LOCATED BELOW LH DASH		
2 INCH ELECTRIC FUEL GAUGE		
ENGINE REMOTE INTERFACE FOR REMOTE THROTTLE		
POWERTRAIN INTERFACE CONNECTOR LOCATED BETWEEN SEATS WITHOUT CAPS		
QUICKFIT PROGRAMMABLE INTERFACE CONNECTOR(S) UNDER CAB WITH BLUNTCUTS		
ENGINE REMOTE INTERFACE CONNECTOR AT POWERTRAIN INTERFACE CONNECTOR		
TMC RP170 INTERFACE CONNECTOR		
DIGITAL DUAL REAR AXLE TEMPERATURE IN DRIVER DISPLAY WITH SENSOR SHIELDS		
ELECTRICAL ENGINE COOLANT TEMPERATURE GAUGE		
DIGITAL TRANSMISSION OIL TEMPERATURE IN DRIVER DISPLAY		



Prepared for:
 SCRANTON MFG CO INC BB
 101 STATE ST
 SCRANTON, IA 51462
 Phone: 712-652-3396

Prepared by:
 A j Mccaffrey
 I-STATE TRUCK CENTER
 4801 HARBOR DRIVE
 SIOUX CITY, IA 51111
 Phone: 712-252-2714
 E-Mail:
 Aj.McCaffrey@istatetruck.com

Description	Weight Front	Weight Rear
ELECTRONIC OUTSIDE TEMPERATURE SENSOR DISPLAY IN DRIVER MESSAGE CENTER		
ENGINE AND TRIP HOUR METERS INTEGRAL WITHIN DRIVER DISPLAY		
PTO CONTROLS FOR ENHANCED VEHICLE ELECTRIC/ELECTRONIC ARCHITECTURE		
NO OBSTACLE DETECTION SYSTEM		
NO DR ASSIST SYSTEM		
NO VEHICLE STABILITY ADVISOR OR CONTROL		
NO LANE DEPARTURE WARNING SYSTEM		
ELECTRIC ENGINE OIL PRESSURE GAUGE		
NO OVERHEAD INSTRUMENT PANEL		
1 QUICKFIT PROGRAMABLE MODULE (QPM/XMC)	10	
AM/FM/WB WORLD TUNER RADIO WITH BLUETOOTH, USB AND AUXILIARY INPUTS, J1939		
ROOF/OVERHEAD CONSOLE MOUNTED RADIO		
(2) RADIO SPEAKERS IN CAB		
AM/FM ANTENNA MOUNTED ON LH SIDE MIRROR		
NO CB RADIO MOUNTING PROVISION		
NO MULTIBAND ANTENNA		
NO DIGITAL SATELLITE AUDIO RECEIVER ANTENNA		
STANDARD RADIO WIRING WITH STEERING WHEEL CONTROLS		
ELECTRONIC MPH SPEEDOMETER WITH SECONDARY KPH SCALE, WITHOUT ODOMETER		
STANDARD VEHICLE SPEED SENSOR		
ELECTRONIC 3000 RPM TACHOMETER		
DETROIT CONNECT PLATFORM HARDWARE		
3 YEARS DAIMLER CONNECTIVITY BASE PACKAGE ON (FEATURES VARY BY MODEL) POWERED BY DETROIT CONNECT ON CUMMINS ENGINES		
NO ASE DATA SVCE EXTENSION		
NO EXTENSIONS		
TMC RP1226 ACCESSORY CONNECTOR LOCATED BEHIND PASSENGER SIDE REMOVEABLE DASH PANEL		
IGNITION SWITCH CONTROLLED ENGINE STOP		



Prepared for:
 SCRANTON MFG CO INC BB
 101 STATE ST
 SCRANTON, IA 51462
 Phone: 712-652-3396

Prepared by:
 A j Mccaffrey
 I-STATE TRUCK CENTER
 4801 HARBOR DRIVE
 SIOUX CITY, IA 51111
 Phone: 712-252-2714
 E-Mail:
 Aj.McCaffrey@istatetruck.com

Description	Weight Front	Weight Rear
PRE-TRIP INSPECTION FEATURE FOR EXTERIOR LAMPS ONLY		
(2) OVERHEAD MOUNTED LANYARD CONTROLS: (1) OFFICER AIR HORN AND (1) DRIVER AIR HORN		
NO TRAILER HAND CONTROL BRAKE VALVE		
DIGITAL TURBO AIR PRESSURE IN DRIVER DISPLAY		
DIGITAL VOLTAGE DISPLAY INTEGRAL WITH DRIVER DISPLAY		
SINGLE ELECTRIC WINDSHIELD WIPER MOTOR WITH DELAY		
ROTARY HEADLAMP SWITCH, MARKER LIGHTS/HEADLIGHTS SWITCH WITH PULL OUT FOR OPTIONAL FOG/ROAD LAMPS		
ONE VALVE PARKING BRAKE SYSTEM WITH WARNING INDICATOR		
SELF CANCELING TURN SIGNAL SWITCH WITH DIMMER, HEADLAMP FLASH, WASH/WIPE/INTERMITTENT		
INTEGRAL ELECTRONIC TURN SIGNAL FLASHER WITH 40 AMP (20 AMP PER SIDE) TRAILER LAMP CAPACITY		

Design

PAINT: ONE SOLID COLOR

Color

CAB COLOR A: L0006EY WHITE ELITE EY
 BLACK, HIGH SOLIDS POLYURETHANE CHASSIS PAINT
 SUNVISOR PAINTED SAME AS CAB COLOR A
 STANDARD E COAT/UNDERCOATING

Certification / Compliance

U.S. FMVSS CERTIFICATION, EXCEPT SALES CABS AND GLIDER KITS

Secondary Factory Options

CORPORATE PDI CENTER IN-SERVICE ONLY
 SHIP TO FONTAINE (MOUNT HOLLY, NC) PRIOR TO DELIVERY

TOTAL VEHICLE SUMMARY



Prepared for:
 SCRANTON MFG CO INC BB
 101 STATE ST
 SCRANTON, IA 51462
 Phone: 712-652-3396

Prepared by:
 A j Mccaffrey
 I-STATE TRUCK CENTER
 4801 HARBOR DRIVE
 SIOUX CITY, IA 51111
 Phone: 712-252-2714
 E-Mail:
 Aj.McCaffrey@istatetruck.com

Weight Summary

	Weight Front	Weight Rear	Total Weight
Factory Weight ⁺	8123 lbs	8142 lbs	16265 lbs
Total Weight ⁺	8123 lbs	8142 lbs	16265 lbs

Extended Warranty

TOWING: 1 YEAR/UNLIMITED MILES/KM EXTENDED TOWING
 COVERAGE \$1200 CAP FEX APPLIES

(+) Weights shown are estimates only.

If weight is critical, contact Customer Application Engineering.

(***) All cost increases for major components (Engines, Transmissions, Axles, Front and Rear Tires) and government mandated requirements, tariffs, and raw material surcharges will be passed through and added to factory invoices.



Prepared for:
 SCRANTON MFG CO INC BB
 101 STATE ST
 SCRANTON, IA 51462
 Phone: 712-652-3396

Prepared by:
 A j Mccaffrey
 I-STATE TRUCK CENTER
 4801 HARBOR DRIVE
 SIOUX CITY, IA 51111
 Phone: 712-252-2714
 E-Mail:
 Aj.McCaffrey@istatetruck.com

D I M E N S I O N S

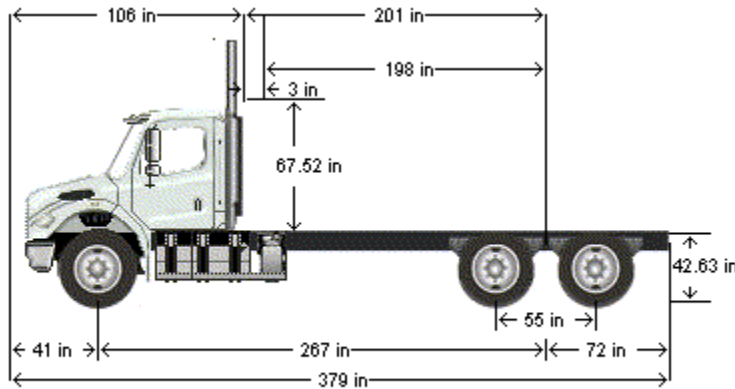

VEHICLE SPECIFICATIONS SUMMARY - DIMENSIONS

Model	M2106
Wheelbase (545)	6775MM (267 INCH) WHEELBASE
Rear Frame Overhang (552)	1825MM (72 INCH) REAR FRAME OVERHANG
Fifth Wheel (578)	NO FIFTH WHEEL
Mounting Location (577)	NO FIFTH WHEEL LOCATION
Maximum Forward Position (in)	0
Maximum Rearward Position (in)	0
Amount of Slide Travel (in)	0
Slide Increment (in)	0
Desired Slide Position (in)	0.0
Cab Size (829)	106 INCH BBC FLAT ROOF ALUMINUM CONVENTIONAL CAB
Sleeper (682)	NO SLEEPER BOX/SLEEPERCAB
Exhaust System (016)	RH OUTBOARD UNDER STEP MOUNTED HORIZONTAL AFTERTREATMENT SYSTEM ASSEMBLY WITH LH B-PILLAR MOUNTED VERTICAL TAILPIPE



Prepared for:
 SCRANTON MFG CO INC BB
 101 STATE ST
 SCRANTON, IA 51462
 Phone: 712-652-3396

Prepared by:
 A j Mccaffrey
 I-STATE TRUCK CENTER
 4801 HARBOR DRIVE
 SIOUX CITY, IA 51111
 Phone: 712-252-2714
 E-Mail:
 Aj.McCaffrey@istatetruck.com

TABLE SUMMARY - DIMENSIONS

Dimensions	Inches
Bumper to Back of Cab (BBC)	106.3
Bumper to Centerline of Front Axle (BA)	40.7
Front Axle to Back of Cab (AC)	65.6
Min. Cab to Body Clearance (CB)	3.0
Back of Cab to Centerline of Rear Axle(s) (CA)	201.2
Effective Back of Cab to Centerline of Rear Axle(s) (Effective CA)	198.2
Back of Cab Protrusions (Exhaust/Intake) (CP)	2.0
Back of Cab Protrusions (Side Extenders/Trim Tab) (CP)	0.0
Back of Cab Protrusions (CNG Tank)	0.0
Back of Cab Clearance (CL)	3.0
Back of Cab to End of Frame	273.1
Cab Height (CH)	67.5
Wheelbase (WB)	266.7
Frame Overhang (OH)	71.9
Overall Frame Length	368.0
Overall Length (OAL)	379.4
Rear Axle Spacing	55.0
Unladen Frame Height at Centerline of Rear Axle	42.6

Performance calculations are estimates only. If performance calculations are critical, please contact Customer Application Engineering.



Prepared for:
 SCRANTON MFG CO INC BB
 101 STATE ST
 SCRANTON, IA 51462
 Phone: 712-652-3396

Prepared by:
 A j McCaffrey
 I-STATE TRUCK CENTER
 4801 HARBOR DRIVE
 SIOUX CITY, IA 51111
 Phone: 712-252-2714
 E-Mail:
 Aj.McCaffrey@istatetruck.com

TURNING RADIUS

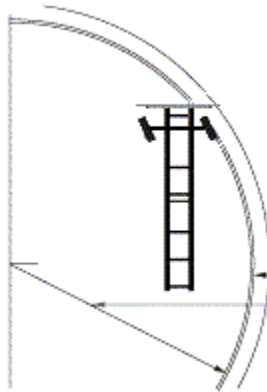

Turning radius graphic and data provided strictly for comparisons between model configurations. Weather, road surfaces, and tire treads affect the results. It is strongly suggested that actual vehicles be measured before constructing any roads/driveways using this information. For specific figures regarding your configuration, please contact your CAE representative.

	Dimensions	Tolerance
Wall to Wall Diameter (ft)	70.5	+/- 3.0
Curb to Curb Diameter (ft)	68.8	+/- 3.0
Turning Radius (ft)	33.9	+/- 1.5

VEHICLE SPECIFICATIONS SUMMARY - TURNING RADIUS

Model M2106
 Cab Size (829)..... 106 INCH BBC FLAT ROOF ALUMINUM CONVENTIONAL CAB
 Wheelbase (545)6775MM (267 INCH) WHEELBASE
 Front Tires (093).....MICHELIN X WORKS Z 315/80R22.5 20 PLY RADIAL FRONT TIRES
 Width (in) 12.5
 Front Axle (400)..... DETROIT DA-F-18.0-5 18,000# FL1 71.0 KPI/3.74 DROP SINGLE FRONT AXLE
 Kingpin Intersection (in) 71
 Bumper (556) THREE-PIECE 14 INCH CHROMED STEEL BUMPER WITH COLLAPSIBLE ENDS
 Width (in) 93.5
 Bumper Miter to Front Axle (in) 21.458
 Primary Steering Location (003) ... LH PRIMARY STEERING LOCATION AND PREP FOR CUSTOMER SUPPLIED RH SIT-DOWN
 SECONDARY STEERING LOCATION WITH DUAL INSTRUMENT CLUSTER
 Steering Gear (536)..... TRW TAS-85 POWER STEERING
 Dual Steering Gear NONE
 Ram NONE
 Rear Axle (420) MERITOR RT-46-160P 46,000# R-SERIES TANDEM REAR AXLE WITH PUMP
 Axle Spacing (624)55 INCH AXLE SPACING

Prepared for:
SCRANTON MFG CO INC BB
101 STATE ST
SCRANTON, IA 51462
Phone: 712-652-3396

Prepared by:
A j Mccaffrey
I-STATE TRUCK CENTER
4801 HARBOR DRIVE
SIOUX CITY, IA 51111
Phone: 712-252-2714
E-Mail:
Aj.McCaffrey@istatetruck.com

Performance calculations are estimates only. If performance calculations are critical, please contact Customer Application Engineering.





120 North Fraser Street • Georgetown, SC 29440 • (843) 545-4000

ACTION ITEM

Council Meeting Date:	March 19, 2026
Department:	Administration
Issue Under Consideration:	Motion to approve second reading of an ordinance amending Chapter 2, Article II, Division 2, Sections 2-31 of the Code of Ordinances for the City of Georgetown.
Amount Requested:	N/A
In Current Budget?:	N/A
If not, please explain:	N/A
Financial Impact:	N/A
Points to Consider:	Approval of the amended ordinance will consolidate the two currently allowable public comment periods into a single public comment opportunity at the beginning of the meeting agenda.
Options:	Approve or Not Approve
Staff Recommendation:	Approve

Reviews:

Stephanie Buccione

Created/Initiated

Approver

Attachments:

1. AN ORDINANCE AMENDING CHAPTER 2 ARTICLE II DIVISION 2 SEC 2-31 CLEAN VERSION
2. AN ORDINANCE AMENDING CHAPTER 2 ARTICLE II DIVISION 2 SEC 2-31 REDLINED VERSION

**AN ORDINANCE AMENDING CHAPTER 2, ARTICLE II, DIVISION 2, SECTIONS 2-31 OF THE
CODE OF ORDINANCES FOR THE CITY OF GEORGETOWN**

WHEREAS, Section 1-9 of the Code of Ordinances of the City of Georgetown allows for the amendment of the Code of Ordinances from time to time; and

WHEREAS, The City Council of the City of Georgetown (“City Council”) recognizes the importance of conducting city business in a productive and efficient manner during its meetings; and

WHEREAS, City Council recognizes the importance of receiving input from citizens wishing to offer public comments during its meetings; and

WHEREAS, City Council wishes to receive public comments on items on the current agenda as well as items pertaining to City of Georgetown matters not on the current agenda during the same time.

NOW, THEREFORE BE IT ORDAINED by the Mayor and City Council of the City of Georgetown, South Carolina, that Section 2-31 of Chapter 2, Article II, Division 2, of the City of Georgetown Code of Ordinances be amended as follows.

Sec. 2-31. Agenda, order of business and regular meetings.

(a) *Matters for the agenda.*

- (1) Any citizen, council member, or department head may request that an item be placed on the city council agenda.
- (2) In the case of citizen or department head requests, the city administrator and mayor shall have the final authority to make the determination whether to place the requested item on the agenda and who will present the item. For department head and council member requests, the department head or mayor and administrator’s designee shall present the item.
- (3) Time for presentation. Any citizen designated by the administrator and mayor to present an item to council shall be limited in time to five (5) minutes.
- (4) Nothing herein is intended to abridge the right of the citizens to address council in public comment under section 2-30 of this article.

(b) *Preparation of the agenda.* Matters to be considered by the city council at a regular meeting shall be placed on a written agenda containing the date, time and place of the meeting. The agenda shall be distributed to city council by 5:00 p.m. the Friday before regular council meetings. The agenda shall be published no later than twenty-four (24) hours prior to the meeting on a bulletin board in a publicly accessible place and on the City of Georgetown website.

(c) *Items not on the agenda.* After the meeting begins, an action item for non-final action may only be added by a vote to amend the agenda by two-thirds of members present and voting. An action item for final action may only be added by a vote to amend the agenda by two-thirds of members present and voting and upon the following express finding: "an emergency or exigent circumstance does or will exist if the [ACTION OR

NAME OF ITEM] is not added to the current meeting agenda for the body's consideration and desired action before the conclusion of this meeting."

- (d) *Order of proceedings.* The order of business at regular meetings of the council shall be as follows:
- (1) Invocation if desired by council;
 - (2) Pledge of Allegiance;
 - (3) *Public comments by citizens (persons wishing to make an appearance will need to sign-in on-site between 5:00—5:25 p.m. the evening of the meeting);*
 - (4) Proclamations;
 - (5) Agenda items;
 - (6) Approval of minutes;
 - (7) Executive session if needed, and potential action item, if needed;
 - (8) Adjournment.

(Ord. of 9-18-03(2); Ord. of 11-18-04; Ord. of 7-23-15; Ord. No. 2022-07, 2-17-22; Ord. No. 2023-07, 4-20-23)

BE IT FURTHER ORDAINED If any portion of this Ordinance proves to be invalid, unlawful, or unconstitutional, it shall not be held to invalidate or impair the validity, force, or effect of any other Section or part of this Ordinance.

ORDAINED by the Mayor and Council of the City of Georgetown, South Carolina, this ____ day of _____, 2026.

ATTEST:

Stephanie Buccione
City Clerk

Jay Doyle
Mayor

First reading:

APPROVED AS TO FORM:

Second reading:

Elise F. Crosby
City Attorney

**AN ORDINANCE AMENDING CHAPTER 2, ARTICLE II, DIVISION 2, SECTIONS 2-31 OF THE
CODE OF ORDINANCES FOR THE CITY OF GEORGETOWN**

WHEREAS, Section 1-9 of the Code of Ordinances of the City of Georgetown allows for the amendment of the Code of Ordinances from time to time; and

WHEREAS, The City Council of the City of Georgetown (“City Council”) recognizes the importance of conducting city business in a productive and efficient manner during its meetings; and

WHEREAS, City Council recognizes the importance of receiving input from citizens wishing to offer public comments during its meetings; and

WHEREAS, City Council wishes to receive public comments on items on the current agenda as well as items pertaining to City of Georgetown matters not on the current agenda during the same time.

NOW, THEREFORE BE IT ORDAINED by the Mayor and City Council of the City of Georgetown, South Carolina, that Section 2-31 of Chapter 2, Article II, Division 2, of the City of Georgetown Code of Ordinances be amended as follows.

Sec. 2-31. Agenda, order of business and regular meetings.

(a) *Matters for the agenda.*

- (1) Any citizen, council member, or department head may request that an item be placed on the city council agenda.
- (2) In the case of citizen or department head requests, the city administrator and mayor shall have the final authority to make the determination whether to place the requested item on the agenda and who will present the item. For department head and council member requests, the department head or mayor and administrator’s designee shall present the item.
- (3) Time for presentation. Any citizen designated by the administrator and mayor to present an item to council shall be limited in time to five (5) minutes.
- (4) Nothing herein is intended to abridge the right of the citizens to address council in public comment under section 2-30 of this article.

(b) *Preparation of the agenda.* Matters to be considered by the city council at a regular meeting shall be placed on a written agenda containing the date, time and place of the meeting. The agenda shall be distributed to city council by 5:00 p.m. the Friday before regular council meetings. The agenda shall be published no later than twenty-four (24) hours prior to the meeting on a bulletin board in a publicly accessible place and on the City of Georgetown website.

(c) *Items not on the agenda.* After the meeting begins, an action item for non-final action may only be added by a vote to amend the agenda by two-thirds of members present and voting. An action item for final action may only be added by a vote to amend the agenda by two-thirds of members present and voting and upon the following express finding: "an emergency or exigent circumstance does or will exist if the [ACTION OR

NAME OF ITEM] is not added to the current meeting agenda for the body's consideration and desired action before the conclusion of this meeting."

(d) *Order of proceedings.* The order of business at regular meetings of the council shall be as follows:

- (1) Invocation if desired by council;
- (2) Pledge of Allegiance;
- (3) *Public comments by citizens ~~on current agenda items~~ (persons wishing to make an appearance ~~regarding a current agenda item~~ will need to sign-in on-site between 5:00—5:25 p.m. the evening of the meeting);*
- (4) Proclamations;
- (5) Agenda items;
- (6) Approval of minutes;
- ~~(7) Public comments by citizens on city services, business, or other city matters not on the agenda (persons wishing to make an appearance pertaining to City of Georgetown matters not on the current agenda will need to sign-in on-site between 5:00—5:25 p.m. the evening of the meeting);~~
- (87) Executive session if needed, and potential action item, if needed;
- (98) Adjournment.

(Ord. of 9-18-03(2); Ord. of 11-18-04; Ord. of 7-23-15; Ord. No. 2022-07, 2-17-22; Ord. No. 2023-07, 4-20-23)

BE IT FURTHER ORDAINED If any portion of this Ordinance proves to be invalid, unlawful, or unconstitutional, it shall not be held to invalidate or impair the validity, force, or effect of any other Section or part of this Ordinance.

ORDAINED by the Mayor and Council of the City of Georgetown, South Carolina, this ____ day of _____, 2026.

ATTEST:

Stephanie Buccione
City Clerk

Jay Doyle
Mayor

First reading:

APPROVED AS TO FORM:

Second reading:

Elise F. Crosby
City Attorney

MAYOR
JAY DOYLE

CITY ADMINISTRATOR
SCOTT WHITTIER

CITY CLERK
STEPHANIE BUCCIONE



COUNCIL MEMBERS
JESSIE WALKER
MAYOR PRO TEMPORE

BRUCE CARL
ERIN ETHRIDGE
SHARON MELTON
HOBSON H. MILTON
TAMIKA WILLIAMS-OBENG

Electric Utility Department
Office: (843) 545-4600

March 9th, 2026

The following is a summary of major activities in the Electric Utility Department for February 2026:

Peak shaving was successful for the month of February. The coincidental electrical peak load, with Santee Cooper, was correctly projected and the generation plant operated both units during those hours. The electric peak load occurred on February 1st, 2026, at 9am. Generators ran a total of 4.1 hours for the month of February.

Upgrades to the air system at the peak shaving plant have been completed. This project added an additional, redundant air compressor, ensuring that the plant can continue operating even if one compressor malfunctions, thereby improving reliability and minimizing potential downtime.

During the month, the Electric Utility Department remained focused on replacing aging poles identified through Osmose Utility Inspections, upgrading pole structures, repairing and installing security lights, and responding to service calls.

The Electric Department has completed upgrades to the raw water pump station, transferring the overhead bank to an underground pad-mount transformer. This improvement enhances system reliability and overall safety.

The February safety meeting was held on February 6th and focused on safe driving practices, proper pre-trip inspections, and the importance of securing loads to ensure safe transportation of equipment and materials. Discussions emphasized hazard awareness, defensive driving techniques, and verifying that all tools, materials, and attachments are properly secured before travel to reduce the risk of accidents and equipment damage.

Other statistics of interest for February:

Electric Department Statistics (FY 2026)

Description	Jul-25	Aug-25	Sep-25	Oct-25	Nov-25	Dec-25	Jan-26	Feb-26	Mar-26	Apr-26	May-26	Jun-26	Totals
Cut-on – regular	48	36	133	59	49	57	22	87					491
Cut-off – regular	49	126	190	154	121	168	139	116					1,063
Cut-off – non-pay	445	394	329	313	346	271	230	196					2,524
Non-pay restores	256	274	267	255	164	301	163	203					1,883
Monthly reads	920	979	840	686	614	662	635	526					5,862
Re-read orders								179					179
Miscellaneous order	3	5	5	6	4	1	5	6					35
Void orders													-
Total orders worked	1,721	1,814	1,764	1,473	1,298	1,460	1,194	1,313	-	-	-	-	12,037
PUPS locates	181	264	363	364	304	223	329	198					2,226

Drawer 939
Georgetown, SC 29442



**City of Georgetown
Engineering Department February 2026 Report**

Date: March 9, 2026

DESIGN

WATER & WASTEWATER

1. Willowbank Watermain Improvements Project (Project #1519)

- Engineer: Thomas & Hutton
- Fee: \$98,500
- Status:
 1. Design work is 100% complete.
 2. Permit applications with SCDOT and DES have been filed for approval.
 3. Waiting for permit agencies feedback.
 4. Bid requests will be released upon permit approvals.

2. Black River Rd Widening Project – Water (Project #1517) & Sewer Line (Project #1817) Relocations

- Engineer: Rowe Professional Services Company
- Fee: \$24,263 (Water) & \$24,263 (Sewer)
- Status:
 1. Design is 100% complete.
 2. DES and SCDOT permits have been approved.

3. WWTP SBR Pre-Engineering (Project #3409)

- Engineer: Bolton & Menk
- Fee: \$21,800
- Status:
 1. Kickoff meeting was held on Friday, January 9th.
 2. Preliminary design work has started.
 3. Final PER should be ready by early April.



**City of Georgetown
Engineering Department February 2026 Report**

4. WTP Upgrades: Disinfection System and Flocc Sed No. 1 (Project #1610)

- Engineer: Ardurra
- Fee: \$342,200
- Status:
 1. Kickoff meeting held on November 18, 2025
 2. Work is ongoing.
 3. PER is complete.
 4. Design work is ongoing.
 5. Ardurra will assist the city in filing the EDA Disaster Supplemental Grant application.

5. Thompson and Loblolly Street Water Main Improvements (Project # 1521)

Engineer: In-House

Status:

1. Design work is complete.
2. Plans have been filed with SCDOT for encroachment permit approvals.
3. Plans will be filed with SCDES for permit approvals: Water, NPDES, and CZC.
4. Permit approvals are still pending.

STORMWATER

1. Stormwater Pump Station Engineering (Project #4017)

Consultant: Ardurra (WK Dickson)

Fee: \$303,225

Status:

- Consultant will complete Preliminary Engineering Report (PER) in early April.
- PER will be presented to City Council. Date: TBD.
- Design work has been put on pause until the presentation and feedback from City council.
- New electric pumps estimate has now been revised to \$3.85M to \$4.25 M.



**City of Georgetown
Engineering Department February 2026 Report**

2. N. Merriman -Congdon Street Stormwater Improvements (Project # 4016)

- Engineer: Rowe Professional
- Fee: \$101,500
- Status:
 1. Design work is 95% complete.
 2. Permit applications with SCDOT and DES have been filed for approval.
 3. Permit approvals are still pending.

PUBLIC WORKS

1. East Bay Park Parking Improvements (Project # 2406)

- Engineer: Cagle Engineers LLC
- Fee: \$39,500
- Status:
 1. Notice of Award issued on 2/20/2026.

CONSTRUCTION

WATER

1. Raw Water Station Electrical Upgrades (Project # 1607)

- Engineer: Howard Engineering
- Contractor: Coastal Structures Corp.
- Notice of Award: 8/16/24
- Revised Contract Amount: \$821,458.15
- Status:
 1. Work is 100% complete, punch list work is now completed.
 2. Substantial completion date is 1/28/2026.
 3. Closeout documents are pending submittal.

2. Maryville Water Distribution Improvements-Phase II (Project # 1518)

- Engineer: Rowe Professional Services
- Contractor: Green Wave Contracting, Inc.
- Notice of Award: 11/24/25
- Contract Amount: \$996,331.



**City of Georgetown
Engineering Department February 2026 Report**

- Status:
 1. Contract agreement is fully executed.
 2. Pre-construction conference was held on 1/13/26.
 3. Notice to Proceed date is 3/16/26.

WASTEWATER

1. Sewer Pump Station Generators-FEMA Grant

- FEMA grant amount: \$160,665.75
- Contractor: Melton Electric.
- Bid Amount: \$215,862
- Notice of Award: 7/26/2022
- Status Comments:

Third portable generator has been delivered.

2. Pump Station #11 and 20-in. Force Main Replacement (SCIIP Project #1820 and #1821)

- Engineer: Ardurra (WK Dickson)
- Division I Pump Station #11 Contractor: Moorhead Construction
 1. Utility equipment, room, concrete foundations and masonry wall are now complete.
 2. Mechanical and electrical work is ongoing.
 3. Generator pad concrete foundation is completed.
 4. Roofing, concrete steps, and handrails work will be next.
- Division II Force Main Contractor: RH Moore Construction
 1. Directional drilling work for new 20-in. force main is scheduled to start on 3/10/26 on Prince Streets from Dozier to Hazard Streets.



**City of Georgetown
Engineering Department February 2026 Report**

2. WWTP Bar Screen Replacement Project #3408

Engineer: In-house

Contractor: Consensus

Contract Amount: \$488,876

Status:

1. Notice of Award issued on 4/21/25.
2. Pre-construction meeting held on 6/9/25.
3. Equipment arrived on 1/30/26.
4. Work started in mid-February.
5. The two bar screens have been replaced.
6. Electrical work is ongoing.

STORMWATER

1. Historic District Stormwater System Improvements-EDA Grant (Project #4015)

- Engineer: Ardurra (WK. Dickson)
- Contractor: Green Wave Contracting, Inc.
- Status: Division I- Front Street Status:
 1. Sidewalk concrete and paver restoration continues.
 2. Paving at CCU parking lot is complete.
 3. Final street asphalt paving is planned for late March.

PUBLIC WORKS

1. Cleland Street Parking Lot -CDBG Grant (Project #2402)

- Engineer: Hanna Engineering
- Contractor: Ben Cox LLC
- Amount: \$332,853.30
- Status:
 1. All work on this project is now complete, except for punch list work.
 2. Substantial completion date is January 30th, 2026.

2. Emanuel Street Sidewalk (Project #1240)

Engineering work has been awarded to Cagle Engineering

Status:

1. Kickoff meeting held on 11/12/25
2. Surveying work is complete.
3. Design work is ongoing.



**City of Georgetown
Engineering Department February 2026 Report**

CITY HALL BLDG.

Project Management (PM) consultant: LCK

Design-Build Contractor: Coastal Structures Corp.

Architect: Graham Leigh Architecture

Status:

1. Work is ongoing with wall framing, MEP rough-ins, roofing, masonry, and concrete. Stucco work is complete. Window frame installation is complete.
2. Security system package has been awarded to HTC.
3. Network wiring has been awarded to HTC.
4. LCK is currently working with vendors for new furniture and AV packages.
5. Lighting plan at the CAB scheduled for March 17th.
6. Coordination of electrical and data outlets with department heads.
7. Coordination of material finishes and colors with department heads.

MUNICIPAL COMPLEX (ELECTRIC & PUBLIC WORKS) BLDG.

Architect: Tych & Walker

Contractor: Coastal Structures

Phase II- Main Building Renovations Status:

Status:

1. Contractor's work is ongoing with the following activities: metal wall framing, electrical wiring, HVAC above-ceiling ductwork, rough-in plumbing.
2. HTC started network wiring this month.

OTHER ACTIVITIES:

1. Coordinate and attend meeting for EDA grant application.
2. Coordinate for Morgan Park pedestrian bridge inspection.
3. Attend meeting with WRCOG for CDBG grant updates.

Prepared by: Orlando Arteaga, P.E., City Engineer

CURRENT PROJECT LISTING REPORT FOR THE PERIOD ENDING 02.28.2026

PROJ #	PO #	PROJECT NAME - DESC/COMMENTS	Vendor	Cost	Projected length of project in days	% remaining open on PO	% Complete	balance remaining on PO
2005	2025-084	City Hall Rebuild - Project Management Services	LCK LLC	155,000.00		1.59%	0.98	2,464.64
2005	2025-027	New City Hall Project	COASTAL STRUCTURES	4,150,484.01		0.86	0.14	3,566,302.48
1234 1923 3501	2025-117	ARCHITECTURAL SERVICES MUNICIPAL COMPLEX	TYCH AND WALKER	73,875.00		23.25%	0.77	17,175.00
1234 1923 3501	2025-280	MUNICIPAL COMPLEX BLDG	COASTAL STRUCTURES	567,265.37		56.11%	0.44	318,274.18
1240	2026-00534	Emanuel street Sidewalk extension	Cagle Engineering	30,500.00		79.02%	0.21	24,100.00
1606	2025-116	WTP Secondary Sedimentation Basin - Engineering Services - EDA Grant #04-79-07777	WK Dickson	526,700.00		7.04%	0.93	37,093.35
1517	2026-00473	Black River Rd Widening Wastewater Engineering	Rowe	24,263.00		47.00%	0.53	11,403.61
1518	2025-170	Maryville Water Distributionn Improvements Phase II	Rowe	70,000.00		22.00%	0.78	15,400.00
1518	2026-00544	Maryville Water Distributionn Improvements Phase II	Greenwave	996,331.00		100.00%	0.00	996,331.00
1519	2025-271	Willowbank Watermain Improvements Project	Thomas & Hutton	104,420.00		44.30%	0.56	46,260.65
1606	2025-093	WTP Secondary Sedimentation Basin/WTP FLOC/SED Basin No. 2 - Construction	Consensus	5,223,180.87		2.60%	0.97	135,850.09
1607	2025-100	Raw Water Station Electrical Upgrades	Howard Engineering	83,480.00		4.68%	0.95	3,910.00
1607	2025-149	Raw Water Station Electrical Upgrades	Coastal Structures	1,082,485.00		7.94%	0.92	85,935.89
1817	2026-00473	Black River Rd Widening Water Engineering	Rowe	24,263.00		47.00%	0.53	11,403.61
1820 & 1821	2025-094	Pump Station #11 and 20 in Force Main Replacement	WK Dickson	1,223,000.00		18.31%	0.82	223,924.13
1820	2025-273	Division 1 Pump Station contractor	Moorhead Construction	6,972,555.00		0.56	0.44	3,913,478.00
1826	2026-564	Sanitary Sewer Manhole Surveys	Weston & Sampson Engineers	86,000.00		1.00	0.00	86,000.00

CURRENT PROJECT LISTING REPORT FOR THE PERIOD ENDING 02.28.2026

PROJ #	PO #	PROJECT NAME - DESC/COMMENTS	Vendor	Cost	Projected length of project in days	% remaining open on PO	% Complete	balance remaining on PO
1821	2025-266	Division 2 force Main Replacement SCIP Project	R H Moore	3,247,960.00		73.90%	0.26	2,400,237.67
1927	2025-114	Front St Under Ground (UG) Infrastructure Upgrade Project - Engineering	Utility Technology	102,500.00		25.16%	0.75	25,788.14
2402	2025-118	Cleland Street Parking Lot - Engineering Services	Hanna Engineering	22,500.00		35.00%	0.65	7,873.99
2406	2026-00605	East Bay Park Parking Lot - Engineering Services	Cagle Engineering	39,500.00		100.00%	0.00	39,500.00
3408	2025-286	WWTP Bar Screen Replacement	consensus construction & consulting	488,876.00		91.76%	0.08	448,585.04
4015	2025-115	Stormwater System Improvements - Engineering - EDA Grant number 04-79-07494 - Change orders 1, 2 & 3 processed 2.17.2023	WK Dickson	567,200.00		8.04%	0.92	45,601.46
4015	2025-092	Historic District Stormwater Improvements	Green Wave	6,251,220.00		11.10%	0.89	693,819.45
4016	2025-263	North Merriman-Congdon st Stormwater Improvements	Rowe Professional	101,500.00		38.15%	0.62	38,720.00
4017	2026-482	Stormwater Pump station engineering	WK Dickson	303,225.00		64.76%	0.35	196,357.91

CITY OF GEORGETOWN
 FY26 GRANTS
 FEB 2026

Ref	Grantor	Program	Award Amount	Match Amount	Expenditures	Balance	Award #	Status
FEDERAL GRANTS								
1	US Department of Commerce	Stormwater System Improvements (EDA) Proj #4015	5,488,526.00	2,405,435.00	6,056,756.58	1,837,204.42	04-79-07494	
2	SC Department of Commerce	Cleland Street Public Parking Lot (CDBG) Proj #2402	250,000.00	110,933.00	230,287.23	130,645.77	4-SP-22-004	
3	Federal Emergency Management Agency (FEMA)	HMGP : Pump Station Generators	192,798.90	21,422.10	147,226.00	66,995.00	4542-0004-R	
4	SC Infrastructure Investment Program (SCIIP)	Sewer Pump Station #11 Replacement Proj #1820	3,888,325.00	686,175.00	4,952,941.46	6,498,514.54	A-23-C079	
		<i>Award \$9,733,783 Match \$1,717,718</i> Sewer Force Main Replacement Proj #1821	5,845,413.00	1,031,543.00				
STATE GRANTS								
5	SC Department of Public Safety	FY26 School Resource Officer Program	272,772.00	-	68,128.87	204,643.13	SR-044-C2202-26	
6	Body Armor Award Grant Program	Bulletproof Vest	11,259.00	-	11,020.74	238.26	1BA24023	
7	Willowbank Water Main Improvements	South Carolina Rural Infrastructure Authority (SC RIA)	1,500,000.00	998,500.00	-	2,498,500.00	R-26-1430	
8	SC Department of Parks, Recreation and Tourism (PRT)	SCPARD EBP Parking Lot Improvements project	140,152.60	-	-	-	2025069	
OTHER GRANTS								
9	State of South Carolina	Gilbert/Hawkins/Butts St Sidewalk Ext. Program Proj# 1236	375,000.00	-	272,683.36	102,316.64	-	
10	SC Department of Environmental Services - SC DES	FY26 Grant # 22.01SW26	13,250.00	-	16,969.31	-	22.01SW26	
11	SCMIRF	2025 Public Works Property and Liability Reduction Grant	4,000.00	4,000.00	2,092.38	5,907.62	-	
12	SCMIT	2025 Law Enforcement Officer Safety - Body Armor Vests	4,000.00	4,000.00	-	8,000.00	-	
13	SCMIRF	2025 Law Enforcement Liability Reduction - Tasers	4,000.00	4,000.00	-	8,000.00	-	
TOTAL			17,989,496.50	5,266,008.10	11,758,105.93	11,360,965.38		

CUSTOM PURCHASE ORDER REPORT FOR CITY OF GEORGETOWN, SC

POST DATES 07/01/2024 - 02/28/2026

STATUS: OPEN & PARTIAL PO STATE: PURCHASE ORDERS



PO/Req Number	Date Posted	Description	Amount	Vendor Name	Vendor Code	PO Status	Remaining Balance
Vendor Code: 10151 CROSBY LAW FIRM LLC							
2026-00384	OK	BLANKET - CITY ATTORNEY'S FEES	25,000.00	CROSBY LAW FIRM LLC	10151	Partial	8,198.65
2026-00545	OK	LEGAL SERVICES	25,000.00	CROSBY LAW FIRM LLC	10151	Partial	16,242.25
Total Vendor Code 10151:			50,000.00				24,440.90
Vendor Code: 10640 BEN COX LLC							
2026-00422	OK	CLELAND STREET PARKING LOT PROJECT 2402 CDBG GRANT 4-SP-22-004	334,118.3	BEN COX LLC	10640	Partial	155,896.57
Total Vendor Code 10640:			334,118.3				155,896.57
Vendor Code: 1128 INDUSTRIAL REWINDING INC							
2026-00589	OK	REWINDING PUMPS	25,000.00	INDUSTRIAL REWINDING INC	1128	Partial	19,226.58
Total Vendor Code 1128:			25,000.00				19,226.58
Vendor Code: 15229 HIGHLAND PRODUCT GROUP LLC							
2026-00585	OK	DSD WASTE CONTAINERS FOR FRONT ST AND CITY PARKS	14,644.07	HIGHLAND PRODUCT GROUP LLC	15229	Open	14,644.07
Total vendor Code 15229:			14,644.07				14,644.07
Vendor Code: 15356 G & W ELECTRIC CO							
2026-00502	OK	DIELECTRIC RECLOSER	25,768.00	G & W ELECTRIC CO	15356	Open	25,768.00
Total Vendor Code 15356:			25,768.00				25,768.00
Vendor Code: 15796 COASTAL ASPHALT LLC							
2026-00542	OK	EAST BAY PARK WALKING TRAIL REPAIRS	18,803.20	COASTAL ASPHALT LLC	15796	Open	18,803.20
Total vendor Code 15796:			18,803.20				18,803.20
Vendor Code: 16070 SPARTAN FIRE & EMERGENCY APPARATUS INC							
2025-00304	OK	EMERGENCY REPAIR TO ENGINE 12	32,030.28	SPARTAN FIRE & EMERGENCY APPARATUS INC	16070	Open	32,030.28
2026-00479	OK	ATV PATIENT TRANSPORT	135,000.0	SPARTAN FIRE & EMERGENCY APPARATUS INC	16070	Open	135,000.00
Total Vendor Code 16070:			167,030.2				167,030.28
Vendor Code: 16312 CANNON TECHNOLOGIES INC							
2026-00412	OK	16S CL320 RFN 530LGS4X RXR QUOTE#24167080 BY JILL SKARSTEN	6,677.76	CANNON TECHNOLOGIES INC	16312	Open	6,677.76
2026-00529	OK	QUOTE#24285172 16S CL320 METERS	6,677.76	CANNON TECHNOLOGIES INC	16312	Open	6,677.76
2026-00546	OK	PER QUOTE 24309677 C2SXD 25 CL200 METERS	26,307.00	CANNON TECHNOLOGIES INC	16312	Open	26,307.00

CUSTOM PURCHASE ORDER REPORT FOR CITY OF GEORGETOWN, SC

POST DATES 07/01/2024 - 02/28/2026

STATUS: OPEN & PARTIAL PO STATE: PURCHASE ORDERS



PO/Req Number	Date Posted	Description	Amount	Vendor Name	Vendor Code	PO Status	Remaining Balance
Vendor Code: 16312 CANNON TECHNOLOGIES INC							
Total Vendor Code 16312:			39,662.52				39,662.52
Vendor Code: 16313 STATEWIDE SECURITY SYSTEMS INC							
2026-00499	OK	SECURITY SYSTEM FOR PUBLIC WORKS	10,200.00	STATEWIDE SECURITY SYSTEMS INC	16313	Partial	4,250.00
2026-00498	OK	STATEWIDE - CITY WIDE CAMERAS	50,400.00	STATEWIDE SECURITY SYSTEMS INC	16313	Partial	12,900.00
Total Vendor Code 16313:			60,600.00				17,150.00
Vendor Code: 16338 SUMTER UTILITIES INC							
2026-00501	OK	ELECTRICAL DISTRIBUTION CONTRACTORS LINE CREW ASSISTANCE	473,335.0	SUMTER UTILITIES INC	16338	Partial	243,341.14
Total Vendor Code 16338:			473,335.0				243,341.14
Vendor Code: 16490 CONSENSUS CONSTRUCTION & CONSULTING INC							
2025-00093	OK	CONSENSUS CONSTRUCTION & CONSULTING - PROJ #1606	1,434,661	CONSENSUS CONSTRUCTION & CONSULTING INC	16490	Partial	135,850.09
2025-00286	OK	HEADWORKS BAR SCREEN REPLACEMENT PROJ 3408	488,876.0	CONSENSUS CONSTRUCTION & CONSULTING INC	16490	Partial	448,585.04
Total Vendor Code 16490:			1,923,537				584,435.13
Vendor Code: 16954 GREEN WAVE CONTRACTING INC							
2025-00092	OK	GREEN WAVE CONTRACTING - PROJ 4015	4,524,493	GREEN WAVE CONTRACTING INC	16954	Partial	693,819.45
2026-00544	OK	MARYVILLE WATER DISTRIBUTION IMPROVEMENTS - PHASE II PROJECT 1518	996,331.0	GREEN WAVE CONTRACTING INC	16954	Open	996,331.00
Total Vendor Code 16954:			5,520,824				1,690,150.45
Vendor Code: 17061 HOLLIDAY UTILITY SERVICES LLC							
2026-00569	OK	FILTER ASSESSMENTS	15,940.00	HOLLIDAY UTILITY SERVICES LLC	17061	Open	15,940.00
Total Vendor Code 17061:			15,940.00				15,940.00
Vendor Code: 17780 BENTON CONCRETE & UTILITIES LLC							
2026-00602	OK	EMERGENCY REPLACE BRICK & CONCRETE AT 829 FRONT STREET	5,950.00	BENTON CONCRETE & UTILITIES LLC	17780	Open	5,950.00
Total Vendor Code 17780:			5,950.00				5,950.00
Vendor Code: 17829 CAGLE CONSULTING ENGINEERS LLC							
2026-00534	OK	EMANUEL STREET SIDEWALK EXTENSION ENGINEERING SERVICES PROJ #1240	30,500.00	CAGLE CONSULTING ENGINEERS LLC	17829	Partial	24,100.00

CUSTOM PURCHASE ORDER REPORT FOR CITY OF GEORGETOWN, SC

POST DATES 07/01/2024 - 02/28/2026

STATUS: OPEN & PARTIAL PO STATE: PURCHASE ORDERS



PO/Req Number	Date Posted	Description	Amount	Vendor Name	Vendor Code	PO Status	Remaining Balance
Vendor Code: 17829 CAGLE CONSULTING ENGINEERS LLC							
2026-00605	OK	EAST BAY PARK PARKING LOT IMPROVEMENTS PROJ #2406	39,500.00	CAGLE CONSULTING ENGINEERS LLC	17829	Open	39,500.00
Total Vendor Code 17829:			70,000.00				63,600.00
Vendor Code: 18055 WESTON & SAMPSON ENGINEERS INC							
2026-00564	OK	SANITARY SEWER MANHOLE SURVEYS PROJ 1826	86,000.00	WESTON & SAMPSON ENGINEERS INC	18055	Open	86,000.00
Total Vendor Code 18055:			86,000.00				86,000.00
Vendor Code: 18315 THE LAW OFFICE OF ERIN E BAILEY LLC							
2026-00475	OK	PUBLIC DEFENDER SERVICES	30,000.00	THE LAW OFFICE OF ERIN E BAILEY LLC	18315	Partial	12,000.00
Total Vendor Code 18315:			30,000.00				12,000.00
Vendor Code: 18317 MECHANICAL EQUIPMENT COMPANY							
2026-00503	OK	REUSE PUMP FOR CL2 POND	65,907.75	MECHANICAL EQUIPMENT COMPANY	18317	Partial	3,500.00
Total Vendor Code 18317:			65,907.75				3,500.00
Vendor Code: 18603 KOPPERS UTILITY AND INDUSTRIAL PRODUCTS INC							
2026-00399	OK	INVENTORY ITEMS	75,000.00	KOPPERS UTILITY AND INDUSTRIAL PRODUCTS INC	18603	Partial	44,077.00
Total Vendor Code 18603:			75,000.00				44,077.00
Vendor Code: 18607 MELTON ELECTRIC CO INC							
2025-00099	OK	MELTON ELECTRIC - PUMP STATION GENERATORS	236,049.5	MELTON ELECTRIC CO INC	18607	Partial	88,823.50
Total Vendor Code 18607:			236,049.5				88,823.50
Vendor Code: 18619 ROWE PROFESSIONAL SERVICES COMPANY							
2025-00170	OK	ROWE PROFESSIONAL SERVICES - ENGINEERING SERVICES PROJECT 1518	62,845.00	ROWE PROFESSIONAL SERVICES COMPANY	18619	Partial	15,400.00
2025-00263	OK	N MERRIMAN -CONGDON STREET STORMWATER IMPROVEMENTS PROJ 4016	101,500.0	ROWE PROFESSIONAL SERVICES COMPANY	18619	Partial	38,720.00
2026-00473	OK	BLACK RIVER RD WIDENING ENGINEERING WASTEWATER PROJ 1817	24,263.00	ROWE PROFESSIONAL SERVICES COMPANY	18619	Partial	11,403.61
2026-00472	OK	BLACK RIVER RD WIDENING ENGINEERING WATER PROJ 1517	24,263.00	ROWE PROFESSIONAL SERVICES COMPANY	18619	Partial	9,660.11
Total Vendor Code 18619:			212,871.0				75,183.72
Vendor Code: 18731 HANNA ENGINEERING LLC							

CUSTOM PURCHASE ORDER REPORT FOR CITY OF GEORGETOWN, SC

POST DATES 07/01/2024 - 02/28/2026

STATUS: OPEN & PARTIAL PO STATE: PURCHASE ORDERS



PO/Req Number	Date Posted	Description	Amount	Vendor Name	Vendor Code	PO Status	Remaining Balance
Vendor Code: 18731 HANNA ENGINEERING LLC							
2025-00118	OK	HANNA ENGINEERING - PROJ #2402 - CDGB #4-SP-22-004	15,140.00	HANNA ENGINEERING LLC	18731	Partial	7,873.99
Total Vendor Code 18731:			15,140.00				7,873.99
Vendor Code: 18736 WRANGLER HOLDCO CORP							
2026-00365	OK	JULY INVOICE FOR GFL	7,103.03	WRANGLER HOLDCO CORP	18736	Open	7,103.03
2026-00414	OK	ANNUAL COMMERCIAL DUMPSTER COLLECTION	78,133.33	WRANGLER HOLDCO CORP	18736	Partial	21,309.09
Total Vendor Code 18736:			85,236.36				28,412.12
Vendor Code: 18809 BORDER STATES INDUSTRIES INC							
2026-00407	OK	INVENTORY ITEMS	75,000.00	BORDER STATES INDUSTRIES INC	18809	Partial	9,826.42
2026-00525	OK	INVENTORY-TRANSFORMER SUPPLIES 5310.0145	15,000.00	BORDER STATES INDUSTRIES INC	18809	Partial	10,747.82
2026-00524	OK	INVENTORY-WIRE 5140.0114	25,000.00	BORDER STATES INDUSTRIES INC	18809	Partial	19,746.28
2026-00516	OK	INVENTORY ITEMS- POLE LINE HARDWARE 5140.0116	35,000.00	BORDER STATES INDUSTRIES INC	18809	Partial	26,787.36
2026-00536	OK	INVENTORY METER SUPPLIES	10,000.00	BORDER STATES INDUSTRIES INC	18809	Partial	4,523.09
Total Vendor Code 18809:			160,000.0				71,630.97
Vendor Code: 18902 COMBS TECHNOLOGIES INC							
2026-00373	OK	CONTROLLER PLC SANITAIRE PART FOR DECANTERS	16,351.74	COMBS TECHNOLOGIES INC	18902	Partial	9,293.02
2026-00467	OK	PLC CONTROLLER/SCREEN LIFT ARM	49,006.07	COMBS TECHNOLOGIES INC	18902	Partial	39,713.05
Total Vendor Code 18902:			65,357.81				49,006.07
Vendor Code: 19062 RAFTELIS FINANCIAL CONSULTANTS INC							
2025-00281	OK	2025 SERVICE FOR UTILITY BILLING ASSESSMENT	38,400.00	RAFTELIS FINANCIAL CONSULTANTS INC	19062	Partial	6,644.37
2026-00405	OK	ELECTRIC UTILITY STUDY- POLE ATTACHEMENTS, LIGHT AGREEMENTS, SOLAR RATES	29,910.00	RAFTELIS FINANCIAL CONSULTANTS INC	19062	Partial	9,765.00
Total Vendor Code 19062:			68,310.00				16,409.37
Vendor Code: 19074 SUNBELT SOLOMON SERVICES LLC							
2026-00398	closed	INVENTORY ITEMS- TRANSFORMERS	75,000.00	SUNBELT SOLOMON SERVICES LLC	19074	Partial	100.00
2026-00550	OK	TRANSFORMER SUPPLIES - BLANKET PO	75,000.00	SUNBELT SOLOMON SERVICES LLC	19074	Open	75,000.00
Total Vendor Code 19074:			150,000.0				75,100.00

CUSTOM PURCHASE ORDER REPORT FOR CITY OF GEORGETOWN, SC

POST DATES 07/01/2024 - 02/28/2026

STATUS: OPEN & PARTIAL PO STATE: PURCHASE ORDERS



PO/Req Number	Date Posted	Description	Amount	Vendor Name	Vendor Code	PO Status	Remaining Balance
Vendor Code: 19316 UTILITY TRANSFORMER BROKERS LLC							
2026-00396	OK	INVENTORY ITEMS TRANSFORMERS	75,000.00	UTILITY TRANSFORMER BROKERS LLC	19316	Partial	7,685.00
2026-00560	OK	INVENTORY ITEMS TRANSFORMER SUPPLIES	75,000.00	UTILITY TRANSFORMER BROKERS LLC	19316	Open	75,000.00
Total Vendor Code 19316:			150,000.0				82,685.00
Vendor Code: 19356 CITI INC							
2026-00436	OK	PROVIDE TWO SCADA PANELS AT SEWER PUMP STATIONS PS#8 AND PS #19	61,525.50	CITI INC	19356	Open	61,525.50
2026-00603	OK	VT SCADA SUPPORT PLUS RENEWAL	5,800.47	CITI INC	19356	Open	5,800.47
Total Vendor Code 19356:			67,325.97				67,325.97
Vendor Code: 19431 KISHA GAMBLE							
2026-00415	OK	JANITORIAL SERVICES	103,499.0	KISHA GAMBLE	19431	Partial	28,227.00
Total Vendor Code 19431:			103,499.0				28,227.00
Vendor Code: 19520 LCK, LLC							
2025-00084	OK	CITY HALL PROJECT MANAGEMENT SERVICES - PROJ 2005	62,373.69	LCK, LLC	19520	Partial	2,464.64
Total Vendor Code 19520:			62,373.69				2,464.64
Vendor Code: 19524 HOWARD ENGINEERING, INC.							
2025-00100	OK	HOWARD ENGINEERING - PROJ 1607	15,980.00	HOWARD ENGINEERING, INC.	19524	Partial	3,910.00
Total Vendor Code 19524:			15,980.00				3,910.00
Vendor Code: 19626 FLEETTEC LLC							
2026-00574	OK	WARNING EQUIPMENT & ELECTRONICS FOR VEHICLE 1157	22,087.01	FLEETTEC LLC	19626	Open	22,087.01
Total Vendor Code 19626:			22,087.01				22,087.01
Vendor Code: 19728 RENTOKIL NORTH AMERICA INC							
**2026-00578	OK	DSD SEASONAL PLANT INSTALLATION	23,546.51	RENTOKIL NORTH AMERICA INC	19728	Open	23,546.51
Total Vendor Code 19728:			23,546.51				23,546.51
Vendor Code: 19855 BOLTON & MENK, INC							
2025-00268	OK	WASTEWATER TREATMENT PLANT CONDITION ASSESSMENT PROJECT 1823	33,200.00	BOLTON & MENK, INC	19855	Partial	2,200.00

CUSTOM PURCHASE ORDER REPORT FOR CITY OF GEORGETOWN, SC

POST DATES 07/01/2024 - 02/28/2026

STATUS: OPEN & PARTIAL PO STATE: PURCHASE ORDERS



PO/Req Number	Date Posted	Description	Amount	Vendor Name	Vendor Code	PO Status	Remaining Balance
Vendor Code: 19855 BOLTON & MENK, INC							
2026-00543	OK	PRELIMINARY ENGINEERING SERVICES FOR WWTP SBR #1 UPGRADES PROJECT 1828	21,800.00	BOLTON & MENK, INC	19855	Open	21,800.00
Total Vendor Code 19855:			55,000.00				24,000.00
Vendor Code: 19864 Thomas & Hutton Engineering Co							
2025-00271	OK	WILLOWBANK WATER MAIN IMPROVEMENTS ENGINEERING SERVICES PROJECT 1519	104,420.0	Thomas & Hutton Engineering Co	19864	Partial	46,260.65
Total Vendor Code 19864:			104,420.0				46,260.65
Vendor Code: 19866 DON MOORHEAD CONSTRUCTION INC							
2025-00273	OK	SCIIP GRANT PROJECT 1820	7,020,755	DON MOORHEAD CONSTRUCTION INC	19866	Partial	3,913,478.00
Total Vendor Code 19866:			7,020,755				3,913,478.00
Vendor Code: 19871 KING ASHPALT INC							
2025-00285	OK	INDIGO AVE ASPHALT RESURFACING PROJECT 1221	136,162.0	KING ASHPALT INC	19871	Partial	10,000.00
Total Vendor Code 19871:			136,162.0				10,000.00
Vendor Code: 19874 JACKLYN J DONEVANT							
2026-00466	OK	CONTRACT SERVICES	10,000.00	JACKLYN J DONEVANT	19874	Partial	70.00
Total Vendor Code 19874:			10,000.00				70.00
Vendor Code: 19900 OSMOSE UTILITIES SERVICES INC							
2026-00442	OK	2025 POLE INSPECTION AND TREATMENT	250,000.0	OSMOSE UTILITIES SERVICES INC	19900	Partial	63,676.26
Total Vendor Code 19900:			250,000.0				63,676.26
Vendor Code: 19903 POMONA LANDSCAPING LLC							
2026-00439	OK	SEASONAL FLORAL MAINTENANCE	36,302.36	POMONA LANDSCAPING LLC	19903	Open	36,302.36
Total Vendor Code 19903:			36,302.36				36,302.36
Vendor Code: 19907 JF ACQUISITION LLC							
2026-00463	OK	VIKING 7 GPM PUMPS, SENSOR 24" LEADS QUOTE QUO-0319033	5,780.07	JF ACQUISITION LLC	19907	Open	5,780.07
Total Vendor Code 19907:			5,780.07				5,780.07
Vendor Code: 19910 AMERICAN WORKING DOG ASSOCIATION							
2026-00606	OK	K9 DOG	6,500.00	AMERICAN WORKING DOG ASSOCIATION	19910	Open	6,500.00
Total Vendor Code 19910:			6,500.00				6,500.00

CUSTOM PURCHASE ORDER REPORT FOR CITY OF GEORGETOWN, SC

POST DATES 07/01/2024 - 02/28/2026

STATUS: OPEN & PARTIAL PO STATE: PURCHASE ORDERS



PO/Req Number	Date Posted	Description	Amount	Vendor Name	Vendor Code	PO Status	Remaining Balance
Vendor Code: 19924 DENISE HAGEMEIER							
2026-00504	OK	PROFESSIONAL SERVICES - CONSULTANT	9,965.00	DENISE HAGEMEIER	19924	Partial	1,197.00
Total Vendor Code 19924:			9,965.00				
Vendor Code: 19931 ALLCON OF GREENVILLE, INC.							
2026-00527	OK	WTP & WWTP ROOF REPAIRS PROJ #1612 & PROJ #3408	144,747.2	ALLCON OF GREENVILLE, INC.	19931	Partial	14,474.72
Total Vendor Code 19931:			144,747.2				
Vendor Code: 19935 ABIGAIL VANCE							
2026-00538	OK	BEN COOPER PARK IMPROVEMENTS PROJECT 2407	57,226.05	ABIGAIL VANCE	19935	Open	57,226.05
Total Vendor Code 19935:			57,226.05				
Vendor Code: 19937 GEOMETRICS CONSULTING, LLC							
2026-00548	OK	INSPECTION SERVICES FOR CITY HALL PROJECT 2005	8,927.00	GEOMETRICS CONSULTING, LLC	19937	Open	8,927.00
Total Vendor Code 19937:			8,927.00				
Vendor Code: 19944 ARDURRA GROUP INC							
2026-00573	OK	WTP UPGRADES NEW DISINFECTION SYSTEM AND SEDIMENTATION FLOCCULATION BASIN REHABILITATION PROJ 1610	342,200.0	ARDURRA GROUP INC	19944	Partial	278,580.00
2026-00576	OK	WTP UPGRADES PROJECT 1610	15,000.00	ARDURRA GROUP INC	19944	Partial	1,500.00
Total Vendor Code 19944:			357,200.0				
Vendor Code: 19949 THE HEIL CO							
**2026-00580	OK	WM GPS TRACKING SYSTEM - SOURCEWELL CONTRACT 110223-THC	14,771.89	THE HEIL CO	19949	Open	14,771.89
Total Vendor Code 19949:			14,771.89				
Vendor Code: 19950 UTILITY SOLUTIONS & AUTOMATION LLC							
2026-00587	OK	WATER METERS	75,000.00	UTILITY SOLUTIONS & AUTOMATION LLC	19950	Open	75,000.00
Total Vendor Code 19950:			75,000.00				
Vendor Code: 19958 SIMPLIFIED OFFICE SYSTEMS							
2026-00601	OK	EPSON PRINT SURECOLOR T5470M PRINTER P/NSCT5470M	5,833.64	SIMPLIFIED OFFICE SYSTEMS	19958	Open	5,833.64

CUSTOM PURCHASE ORDER REPORT FOR CITY OF GEORGETOWN, SC

POST DATES 07/01/2024 - 02/28/2026

STATUS: OPEN & PARTIAL PO STATE: PURCHASE ORDERS



PO/Req Number	Date Posted	Description	Amount	Vendor Name	Vendor Code	PO Status	Remaining Balance
Vendor Code: 19958 SIMPLIFIED OFFICE SYSTEMS							
Total Vendor Code 19958:			5,833.64				5,833.64
Vendor Code: 205 INTERNATIONAL PAPER COMPANY							
2026-00517	OK	SOLE SOURCE - BLANKET - RAW WATER - BUS LIC AND INS NA	25,000.00	INTERNATIONAL PAPER COMPANY	205	Partial	1,436.17
2026-00596	OK	IP WATER PURCHASES FOR WTP	35,000.00	INTERNATIONAL PAPER COMPANY	205	Open	35,000.00
Total Vendor Code 205:			60,000.00				36,436.17
Vendor Code: 2709 PETE DUTY & ASSOCIATES, INC.							
2026-00395	OK	SULZER 12 HP PUMP	9,630.00	PETE DUTY & ASSOCIATES, INC.	2709	Open	9,630.00
Total Vendor Code 2709:			9,630.00				9,630.00
Vendor Code: 356 THOMAS SUPPLY CO INC							
2026-00371	OK	ELECTRICAL WIRE FOR SBR EQUIPMENT REPAIRS	10,000.00	THOMAS SUPPLY CO INC	356	Partial	3,184.10
Total Vendor Code 356:			10,000.00				3,184.10
Vendor Code: 3613 MOTOROLA SOLUTIONS INC							
2026-00500	OK	SCDPS RADIO REPLACEMENT	129,821.0	MOTOROLA SOLUTIONS INC	3613	Open	129,821.04
2026-00535	OK	MOBILE VEHICLE RADIOS	37,207.53	MOTOROLA SOLUTIONS INC	3613	Open	37,207.53
Total Vendor Code 3613:			167,028.5				167,028.57
Vendor Code: 3968 GEORGETOWN COUNTY LANDFILL							
2026-00509	OK	LANDFILL FEES	25,000.00	GEORGETOWN COUNTY LANDFILL	3968	Partial	5,519.06
Total Vendor Code 3968:			25,000.00				5,519.06
Vendor Code: 4137 R H MOORE INC							
2025-00266	OK	DIVISION II FORCE MAIN REPLACEMENT SCIIP GRANT A-23-C079 PROJECT 1821	3,247,960	R H MOORE INC	4137	Partial	2,400,237.67
Total Vendor Code 4137:			3,247,960				2,400,237.67
Vendor Code: 4200 GEORGETOWN COUNTY BOARD OF DISABILITIES							
2026-00383	OK	RESIDENTIAL RECYCLING-BLANKET JUL 2025-JUN 2026	53,000.00	GEORGETOWN COUNTY BOARD OF DISABILITIES	4200	Partial	28,636.24
Total Vendor Code 4200:			53,000.00				28,636.24
Vendor Code: 4942 NAFECO INC							
2026-00561	OK	FIREFIGHTER TURN OUT GEAR	22,202.50	NAFECO INC	4942	Open	22,202.50

CUSTOM PURCHASE ORDER REPORT FOR CITY OF GEORGETOWN, SC

POST DATES 07/01/2024 - 02/28/2026

STATUS: OPEN & PARTIAL PO STATE: PURCHASE ORDERS



PO/Req Number	Date Posted	Description	Amount	Vendor Name	Vendor Code	PO Status	Remaining Balance
Vendor Code: 4942 NAFECO INC							
Total Vendor Code 4942:			22,202.50				22,202.50
Vendor Code: 5010 TYCH & WALKER ARCHITECTS, LLP							
2025-00117	OK	TYCH & WALKER ARCHITECTS - PROJ 1234 1926 3501	24,275.00	TYCH & WALKER ARCHITECTS, LLP	5010	Partial	17,175.00
Total Vendor Code 5010:			24,275.00				17,175.00
Vendor Code: 5284 UTILITY SERVICE COMPANY							
2026-00552	OK	PROVIDE INSPECTIONS, WASHOUT, AND PAINT MAINTENANCE REHAB WORK OF ALL THREE WATER TANKS	44,738.00	UTILITY SERVICE COMPANY	5284	Partial	33,553.50
Total Vendor Code 5284:			44,738.00				33,553.50
Vendor Code: 5417 W K DICKSON & CO INC							
2025-00094	OK	WK DICKSON & CO - SCIIIP GRANT AWARD PROJ 1820 & 18201	431,717.1	W K DICKSON & CO INC	5417	Partial	223,924.13
2025-00115	OK	W K DICKSON - PROJ #4015 - EDA GRANT #04-79-07494	223,688.5	W K DICKSON & CO INC	5417	Partial	45,601.46
2025-00116	OK	WK DICKSON - PROJ #1606	97,032.36	W K DICKSON & CO INC	5417	Partial	37,093.35
2026-00482	OK	ENGINEERING SERVICES FOR NEW STORMWATER PUMPS PROJ 4017	303,225.0	W K DICKSON & CO INC	5417	Partial	196,357.91
Total Vendor Code 5417:			1,055,663				502,976.85
Vendor Code: 5615 HTC COMMUNICATIONS INC							
2026-00490	OK	AUTOMATIC LOCKS FOR PUBLIC RESTROOMS	22,523.95	HTC COMMUNICATIONS INC	5615	Open	22,523.95
2026-00572	OK	CLOUD MANAGEMENT	13,653.75	HTC COMMUNICATIONS INC	5615	Open	13,653.75
2026-00581	OK	CLOUD MANAGEMENT	68,268.75	HTC COMMUNICATIONS INC	5615	Open	68,268.75
2026-00607	OK	LABOR AND MATERIAL TO WIRE NEW ELECTRIC BUILDING PROJECT #1926 ,1234, 3501	6,978.18	HTC COMMUNICATIONS INC	5615	Open	6,978.18
Total Vendor Code 5615:			111,424.6				111,424.63
Vendor Code: 6254 UTILITY TECHNOLOGY ENGINEERS-CONSULTANTS PLLC							
2025-00037	OK	UTILITY TECHNOLOGY ENGINEERING - PROJ 1931 PHASE 3	28,932.76	UTILITY TECHNOLOGY ENGINEERS-CONSULTANTS PLLC	6254	Partial	21,324.35
2025-00114	OK	UTILITY TECHNOLOGY - PROJ 1927 ROLLOVER FROM PO#2024-124	25,788.14	UTILITY TECHNOLOGY ENGINEERS-CONSULTANTS PLLC	6254	Open	25,788.14

CUSTOM PURCHASE ORDER REPORT FOR CITY OF GEORGETOWN, SC

POST DATES 07/01/2024 - 02/28/2026

STATUS: OPEN & PARTIAL PO STATE: PURCHASE ORDERS



PO/Req Number	Date Posted	Description	Amount	Vendor Name	Vendor Code	PO Status	Remaining Balance
Vendor Code: 6254 UTILITY TECHNOLOGY ENGINEERS-CONSULTANTS PLLC							
2025-00223	OK	CONSTRUCTION SERVICES FOR FRONT STREET PROJECT #1931	39,300.00	UTILITY TECHNOLOGY ENGINEERS-CONSULTANTS PLLC	6254	Partial	18,982.37
2026-00470	OK	GIS ELECTRIC SYSTEM MAPPING CONTINUED FROM 2024/2025 FISCAL YEAR	90,000.00	UTILITY TECHNOLOGY	6254	Partial	14,541.45
2026-00528	OK	MARINA DRIVE UNDERGROUND LOOP PROJ #1931	69,100.00	UTILITY TECHNOLOGY	6254	Partial	54,798.99
2026-00590	OK	BLACK RIVER ROAD WIDENING PROJECT#1933	151,430.00	UTILITY TECHNOLOGY	6254	Open	151,430.00
Total vendor code 6254:			<u>404,550.9</u>				<u>286,865.30</u>
Vendor Code: 6524 COASTAL STRUCTURES CORPORATION							
2025-00027	OK	COASTAL STRUCTURES CORP - PROJECT 2005	4,150,484	COASTAL STRUCTURES CORPORATION	6524	Partial	3,566,302.48
2025-00149	OK	COASTAL STRUCTURES - PROJ 1607	843,878.8	COASTAL STRUCTURES CORPORATION	6524	Partial	85,935.89
2025-00280	OK	PHASE 1 METAL BLDG MUNICIPAL COMPLEX- PROJECT 1234 , 1926 , 3501	629,027.9	COASTAL STRUCTURES CORPORATION	6524	Partial	318,274.18
2026-00400	OK	CONSULTING SERVICES HARRY JOHNSON	40,000.00	COASTAL STRUCTURES CORPORATION	6524	Partial	6,160.00
2026-00408	OK	MUNICIPAL BUILDING COMPLEX PHASE II MAIN BUILDING RENOVATIONS PROJ -1926 1234 3501	1,090,709	COASTAL STRUCTURES CORPORATION	6524	Partial	998,947.95
2026-00566	OK	FIRE TRAINING CENTER CONSTRUCTION	89,945.64	COASTAL STRUCTURES CORPORATION	6524	Open	89,945.64
Total vendor code 6524:			<u>6,844,046</u>				<u>5,065,566.14</u>
Vendor Code: 670 ALTEC INDUSTRIES INC							
2026-00577	OK	2027 ALTEC MODEL LR860-E70 AERIAL DEVICE-ROUTE 1883592-2 BY ABBOTT TOBIN GADDY	232,738.0	ALTEC INDUSTRIES INC	670	Open	232,738.00
Total vendor code 670:			<u>232,738.0</u>				<u>232,738.00</u>
Vendor Code: 6700 ST FRANCES ANIMAL CENTER							
2026-00392	OK	CONTRACT SERVICES FOR ANIMAL CONTROL	85,000.00	ST FRANCES ANIMAL CENTER	6700	Partial	42,500.00
Total vendor code 6700:			<u>85,000.00</u>				<u>42,500.00</u>
Vendor Code: 7196 SET SOLUTIONS, LLC							
2026-00385	OK	COG SAFETY TRAINING	25,000.00	SET SOLUTIONS, LLC	7196	Partial	20,500.00

CUSTOM PURCHASE ORDER REPORT FOR CITY OF GEORGETOWN, SC

POST DATES 07/01/2024 - 02/28/2026

STATUS: OPEN & PARTIAL PO STATE: PURCHASE ORDERS



PO/Req Number	Date Posted	Description	Amount	Vendor Name	Vendor Code	PO Status	Remaining Balance
Vendor Code: 7196 SET SOLUTIONS, LLC							
Total Vendor Code 7196:			25,000.00				20,500.00
Vendor Code: 7285 DELL MARKETING L. P.							
2026-00428	OK	LEASE FOR 4 YEARS	138,797.9	DELL MARKETING L. P.	7285	Partial	129,993.05
Total Vendor Code 7285:			138,797.9				129,993.05
Vendor Code: 75 CHLORINATOR SALES & SERVICE INC							
2026-00595	OK	CHLORINE SYSTEM ANNUAL MAINTENANCE WWTP	16,000.00	CHLORINATOR SALES & SERVICE INC	75	Open	16,000.00
2026-00594	OK	CHLORINE SYSTEM ANNUAL MAINTENANCE WTP	9,000.00	CHLORINATOR SALES & SERVICE INC	75	Open	9,000.00
Total Vendor Code 75:			25,000.00				25,000.00
Vendor Code: 7749 CAROLINA INTERNATIONAL TRUCKS							
2025-00261	OK	PURCHASE OF A 2026 HX250 SFA DUMP TRUCK	282,698.0	CAROLINA INTERNATIONAL TRUCKS	7749	Open	282,698.06
Total Vendor Code 7749:			282,698.0				282,698.06
Vendor Code: 7936 TANNER INDUSTRIES, INC.							
2026-00424	OK	AMMONIA	20,000.00	TANNER INDUSTRIES, INC.	7936	Partial	16,070.37
Total Vendor Code 7936:			20,000.00				16,070.37
Vendor Code: 8540 LINE EQUIPMENT SALES CO INC							
2026-00406	OK	INVENTORY ITEMS	75,000.00	LINE EQUIPMENT SALES CO INC	8540	Partial	55,967.90
2026-00559	OK	INVENTORY TRANSFORMER SUPPLIES	15,000.00	LINE EQUIPMENT SALES CO INC	8540	Partial	11,879.69
Total Vendor Code 8540:			90,000.00				67,847.59
Vendor Code: 8794 GEORGETOWN ALCOHOL AND DRUG AB							
2026-00440	OK	GEORGETOWN ALCOHOL AND DRUG AB	76,128.00	GEORGETOWN ALCOHOL AND DRUG AB	8794	Open	76,128.00
Total Vendor Code 8794:			76,128.00				76,128.00
Vendor Code: 8898 DEERE & COMPANY							
**2026-00591	OK	ZERO TURN LAWN MOWER GROUND MAINTENANCE	16,006.73	DEERE & COMPANY	8898	Open	16,006.73
Total Vendor Code 8898:			16,006.73				16,006.73
Vendor Code: 89 INDUSTRIAL SOLUTIONS & SUPPLY							
2025-00040	OK	INDUSTRIAL SOLUTIONS - SULFURIC ACID	25,000.00	INDUSTRIAL SOLUTIONS & SUPPLY	89	Partial	17,818.74
2026-00377	OK	25% SODIUM HYDROXIDE (CAUSTIC)	25,000.00	INDUSTRIAL SOLUTIONS & SUPPLY	89	Partial	2,416.74
2026-00375	OK	50% SULFURIC ACID	25,000.00	INDUSTRIAL SOLUTIONS & SUPPLY	89	Open	25,000.00

CUSTOM PURCHASE ORDER REPORT FOR CITY OF GEORGETOWN, SC

POST DATES 07/01/2024 - 02/28/2026

STATUS: OPEN & PARTIAL PO STATE: PURCHASE ORDERS



PO/Req Number	Date Posted	Description	Amount	Vendor Name	Vendor Code	PO Status	Remaining Balance
Vendor Code: 89 INDUSTRIAL SOLUTIONS & SUPPLY							
2026-00426	OK	POLYMER	25,000.00	INDUSTRIAL SOLUTIONS & SUPPLY	89	Partial	13,917.95
2026-00522	OK	HYPER+ION 9254 (PAC)	25,000.00	INDUSTRIAL SOLUTIONS & SUPPLY	89	Partial	10,688.00
2026-00519	OK	25% SODIUM HYDROXIDE CAUSTIC SODA	25,000.00	INDUSTRIAL SOLUTIONS & SUPPLY	89	Partial	13,263.87
2026-00537	OK	HYPER+ION 9254 (PAC)	75,000.00	INDUSTRIAL SOLUTIONS & SUPPLY	89	Partial	2,832.40
2026-00593	OK	HYPER+ION 9254 (PAC)	75,000.00	INDUSTRIAL SOLUTIONS & SUPPLY	89	Open	75,000.00
Total Vendor Code 89:			300,000.00				160,937.70
Vendor Code: 8905 PVS TECHNOLOGIES INC							
2026-00379	OK	FERRIC CHLORIDE	75,000.00	PVS TECHNOLOGIES INC	8905	Partial	20,799.12
Total Vendor Code 8905:			75,000.00				20,799.12
Vendor Code: 9046 STONE CONSTRUCTION							
2026-00448	OK	BLANKET FOR STOCKPILE, FLBC, LIMESTONE, DIRT AND ROCK	25,000.00	STONE CONSTRUCTION	9046	Partial	12,090.70
Total Vendor Code 9046:			25,000.00				12,090.70
Vendor Code: 9253 CONWAY FORD INC							
2026-00533	OK	2026 F150 4X2 SUPER CREW CAB TRUCK VEHICLE 1515	42,239.00	CONWAY FORD INC	9253	Open	42,239.00
2026-00532	OK	PW PICKUP TRUCK VEHICLE 1214	42,239.00	CONWAY FORD INC	9253	Open	42,239.00
2026-00531	OK	2026 FORD RANGER 4X2 SUPERCREW VEHICLE 366	37,344.00	CONWAY FORD INC	9253	Open	37,344.00
2026-00604	OK	2026 F-250 4X2 SUPER CAB	62,143.00	CONWAY FORD INC	9253	Open	62,143.00
Total Vendor Code 9253:			183,965.00				183,965.00
Vendor Code: 9846 ANDRITZ SEPARATION INC							
2026-00518	OK	SOLE SOURCE REPAIRS TO BELT PRESS - NO ON SITE WORK - GOODS ONLY - BUS LIC AND INS NA	24,407.66	ANDRITZ SEPARATION INC	9846	Open	24,407.66
Total Vendor Code 9846:			24,407.66				24,407.66
Vendor Code: 9902 BRENNTAG MID-SOUTH INC							
2026-00378	closed	25% SODIUM HYDROXIDE	25,000.00	BRENNTAG MID-SOUTH INC	9902	Partial	864.60
2026-00471	closed	ORTHOPHOSHPHATE	25,000.00	BRENNTAG MID-SOUTH INC	9902	Partial	225.00
Total Vendor Code 9902:			50,000.00				1,089.60
Vendor Code: 9909 JONES CHEMICALS INC							

CUSTOM PURCHASE ORDER REPORT FOR CITY OF GEORGETOWN, SC

POST DATES 07/01/2024 - 02/28/2026

STATUS: OPEN & PARTIAL PO STATE: PURCHASE ORDERS



PO/Req Number	Date Posted	Description	Amount	Vendor Name	Vendor Code	PO Status	Remaining Balance
Vendor Code: 9909 JONES CHEMICALS INC							
2026-00376 <i>OK</i>		TON CHLORINE CYLINDERS	75,000.00	JONES CHEMICALS INC	9909	Partial	34,716.92
2026-00380 <i>OK</i>		TON CHLORINE CYLINDERS	25,000.00	JONES CHEMICALS INC	9909	Partial	13,872.17
Total Vendor Code 9909:			<u>100,000.0</u>				<u>48,589.09</u>
Vendor Code: 9948 CAROLINA COOL INC							
2026-00599 <i>OK</i>		HVAC SYSTEM	12,375.00	CAROLINA COOL INC	9948	Open	12,375.00
Total Vendor Code 9948:			<u>12,375.00</u>				<u>12,375.00</u>
Report Total:			<u>32,580.12</u>				<u>18,502,050.75</u>

CITY OF GEORGETOWN

Vehicle and Heavy Equipment Purchase Listing

February 28, 2026

Description	Department	Cost
2025 Ford Explorer	Police	73,827.50
2025 Ford Explorer	Police	73,827.50
2025 Ford Explorer	Police	73,827.50
2025 Ford Explorer	Police	73,827.50
2026 Ford Explorer Equipment (Vehicle not delivered yet)	Police	4,209.64
2026 Ford Explorer Equipment (Vehicle not delivered yet)	Police	4,209.64
2025 Ford Explorer	Police	62,541.00
2026 Ford Explorer	Police	72,424.21
John Deere Bush Hog	Public Works	41,641.36
Bobcat Skid Steer Loader	Public Works	48,221.60
Bobcat Skid Steer Loader	Water Distribution	55,565.56
2026 Chevrolet Equinox	Water Filtration	34,005.00
2025 F250 Super Duty Truck	Wastewater	57,449.00
2026 John Deere Backhoe	Wastewater	127,923.30
2024 John Deere Loader (Tink Claw) FY25 Budget	Waste Management	127,680.01
2026 International : Scow body Dump Truck	Waste Management	196,149.75
2026 Ford Explorer	Electric	45,225.00
F550 Super Cab 4X4 Bucket Truck	Electric	196,403.00
2025 Bobcat Forklift	Wastewater Treatment Plant	49,919.31
2026 Ford Explorer	Fire	45,680.00
		1,464,557.38

Finance Department

February 2026 Report

Business License Activity

New Business Licenses Issued

- RENAULT CREATIVE RESTAURANT SOLUTIONS
- JOE JOHNSON EQUIPMENT, LLC (HDL)
- DARCOM, LLC (HDL)
- SHIV SHAKTI PROPERTY, LLC (HDL)
- Garcias LANDSCAPING, LLC
- CC FERRER LLC (HDL)
- GLENN CECCHINE
- KEVIN OWENS
- TWIN ELECTRICAL, LLC

Business License Ordinance Update

South Carolina Business License Tax Standardization Act (Act 176):

During the City's first season of issuing business licenses under Act 176, Council approved the Business License Ordinance on September 15, 2022, incorporating the required standardization procedures and requirements. Chapter 1, Article II, *Business Licenses*, of the Code of Ordinances for the City of Georgetown was replaced in its entirety.

Update:

The second reading of the Business License Ordinance update was held on December 18, 2025, and was approved by Council. The updated ordinance has been submitted to the MASC portal.

Renewals:

- **Business license renewal notices were sent out February 28, 2026.**
- Finance continues to receive and process renewals through the online portal, in person, and by mail.

HDL Companies

The city received and approved the February 2026 listing of potential businesses operating without a business license from HDL Companies (see Active Businesses Report).

In accordance with the contract, the City received approved payments from three companies totaling **\$5,380.52**, prior to reimbursement to HDL Companies.

Projects in Progress

Grants:

Please refer to the attached grant schedule for details on each award.

Financial Statement Audit (FY 2023–FY 2025):

As required, Procurement issued an RFP for financial statement audit services for FY 2023, FY 2024, and FY 2025. Based on the proposals received, Finance recommended Mauldin & Jenkins. Council approved this recommendation on May 19, 2022.

The Finance Department received notification that the City was awarded the **GFOA Certificate of Achievement for Excellence in Financial Reporting** for FY 2024.

- **Mauldin and Jenkins presented the FY2025 Financial Audit to council on February 19, 2026.**
- Audit fieldwork was completed on January 31, 2026.
- The FY 2025 audit has been submitted to GFOA and DAC for bond reporting.
- Audit work for FY 2025 began in July, with fieldwork scheduled to start the week of October 13, 2025.

Budget

- **Annual Budget Retreat will be held on March 26, 2026.**
- Department Head budget reviews with Finance and the City Administrator were held during the week of February 17–20, 2026.
- Department budget proposals were due to Finance by February 4, 2026.
- Council approved the FY 2026–2027 Budget Calendar during its regular meeting on January 15, 2026.
- The FY 2025–2026 Budget began on **July 1, 2025.**

Other Items

- The Finance Department currently has no vacancies.
- The **January Budget Performance Report** is attached. Due to earlier council agenda deadlines, monthly financial information reflects the prior month.

CITY OF GEORGETOWN
SALE OF ASSETS - FY26

GovDeal	Payment	Govdeal #	Asset ID	Dept.	Description	Amount/Total Proceeds	Notations	Receipt #
	07.10.2025	657	16006	WATER	2014 FORD F250	\$13,600.00	AUCTIONED IN JUNE	2025-00063932
	07.10.2025	647	10705	PW	1996 FORD FT900F	\$5,550.00	AUCTIONED IN JUNE	2025-00063930
	07.10.2025	649	10818	WATER	1194 GMC C7HO64	\$5,550.00	AUCTIONED IN JUNE	2025-00063928
	07.10.2025	654	12161	PW	2009 FORD F250	\$5,350.00	AUCTIONED IN JUNE	2025-00063927
	7.10.2025	637	10040	B&P	1197 FORD F150	\$5,050.00	AUCTIONED IN JUNE	2025-00063926
	07.09.2025	644	10644	ELEC	2007 FORD F150	\$4,501.00	AUCTIONED IN JUNE	2025-00063903
	07.09.2025	650	11234	WATER	2005 FORD F150	\$4,275.00	AUCTIONED IN JUNE	2025-00063901
	07.09.2025	642	10181	FLEET	2004 CHEVY SILVERADO	\$4,000.00	AUCTIONED IN JUNE	2025-00063898
	07.09.2025	656	13002	POL	2010 CROWN VIC	\$2,925.00	AUCTIONED IN JUNE	2025-00063897
	07.09.2025	653	12159	POL	2008 CROWN VIC	\$2,850.00	AUCTIONED IN JUNE	2025-00063896
	07.09.2025	641	10177	MC	2006 CHEV IMPALA	\$2,046.00	AUCTIONED IN JUNE	2025-00063893
	07.09.2025	661	16014A	POL	2014 FORD TAURUS	\$2,000.00	AUCTIONED IN JUNE	2025-00063891
	07.09.2025	658	16008A	POL	2014 FORD TAURUS	\$575.00	AUCTIONED IN JUNE	2025-00063888
	07.14.2025	645	10645	ELEC	1990 FORD F800 BUCKET TRUCK	\$4,501.00	AUCTIONED IN JUNE	2025-00064551
	07.14.2025	648	10717	PW	2005 GMC GARBAGE TRUCK	\$8,800.00	AUCTIONED IN JUNE	2025-00064556
	07.14.2025	660	16013A	POL	2014 FORD TAURUS	\$722.00	AUCTIONED IN JUNE	2025-00064562
	07.14.2025	643	10185	POL	2006 DODGE RAM	\$4,550.00	AUCTIONED IN JUNE	2025-00064564
	07.14.2025	640	10119	FLEET	1992 DODGE D250	\$3,400.00	AUCTIONED IN JUNE	2025-00064567
	07.21.2025	662	19007	WATER	2004 STERLING TRUCK	\$26,800.00	AUCTIONED IN JUNE	2025-00065748
	07.21.2025	665	17033	PW	2015 JOHN DEERE WHEEL LOADER	\$20,300.00	AUCTIONED IN JUNE	2025-00065749
	07.29.2025	652	12013	POL	2008 CHEV TRALIBLAZER	\$1,127.00	AUCTIONED IN JUNE	2025-00067726
	07.29.2025	655	12226	POL	2009 DODGE CHARGER	\$1,666.00	AUCTIONED IN JUNE	2025-00067710
Total July						\$130,138.00		
	08.11.2025	646	10663	PW	1998 Ford F800 Grapple Truck	12,005.00	AUCTIONED IN JUNE	2025-00070043
Total August						12,005.00		
no activity								
Total September						0.00		
no activity								
Total October						0.00		
no activity								
Total November						0.00		

CITY OF GEORGETOWN
SALE OF ASSETS - FY26

GovDeal Payment	Govdeal #	Asset ID	Dept.	Description	Amount/Total Proceeds	Notations	Receipt #
12.15.2025	666		POLICE	USED BIKES	\$50.00	AUCTIONED IN NOVEMBER	2026-00093848
Total December					50.00		
01.05.2026	667	14013	WWTP	USED PUMPS	\$300.00	AUCTIONED IN JANUARY	2026-00006897
Total January					\$300.00		
02.06.2026	670	21017	IT	LOT OF DELL COMPUTER TOWERS	\$1,500.00	AUCTIONED IN FEBRUARY	
02.13.2026	674		POLICE	PAPER TRIMMER	\$82.00	AUCTIONED IN FEBRUARY	
02.13.2026	673		POLICE	CHAIN GRINDER	\$140.00	AUCTIONED IN FEBRUARY	
02.13.2026	672		POLICE	LABEL PRINTER	\$120.00	AUCTIONED IN FEBRUARY	
02.06.2026	671		POLICE	RIFLE AND SHOTGUN VEHICLE RACK	\$160.00	AUCTIONED IN FEBRUARY	
Total February					\$2,002.00		
Total March					-		
Total April					-		
Total May							
Total June					-		
TOTAL PER G/L					144,495.00		
				ASSET GL 0010.00.00.3910.0001	143,943.00		
				MISC GL 0010.00.00.3690.0002	\$552.00		
					144,495.00		

BUDGET REPORT FOR CITY OF GEORGETOWN, SC
Calculations As of 01/31/2026

GL Number	Description	Original	25-26 Budget	25-26 Amended Budget	25-26 Amended Budget	25-26 Activity	25-26 Encumbrance	% Budget	25-26 Used
Fund: 0010 General Fund									
Account Category: Estimated Revenues									
0010.00.00.3020.0008	Opioid Recovery Program		110,000	0	110,000	0	0		0.00
0010.00.00.3110.0001	Property Taxes - Real	5,966,289		0	5,966,289	493,510	0		8.27
0010.00.00.3110.0003	Property Taxes - Vehicles	425,000		0	425,000	240,814	0		56.66
0010.00.00.3110.0004	Inventory Tax	132,978		0	132,978	66,489	0		50.00
0010.00.00.3110.0005	Prop Tax-Penalties & Cost	30,000		0	30,000	0	0		0.00
0010.00.00.3110.0006	Homestead Exemption Tax	156,000		0	156,000	0	0		0.00
0010.00.00.3110.0007	Manufacturer's Tax Reduce	135,000		0	135,000	0	0		0.00
0010.00.00.3110.0008	Motor Carrier Lieu of Tax	18,000		0	18,000	7,567	0		42.04
0010.00.00.3110.0011	Boat and Motor Taxes	75,000		0	75,000	40,418	0		53.89
0010.00.00.3210.0001	Business Licenses	4,000,000		0	4,000,000	154,772	0		3.87
0010.00.00.3210.0002	Business Lic - Penalites	19,500		0	19,500	(15,232)	0		(78.11)
0010.00.00.3220.0001	Cable TV Franchise	140,000		0	140,000	44,477	0		31.77
0010.00.00.3220.0002	S.C. Electric & Gas Co.	89,000		0	89,000	0	0		0.00
0010.00.00.3230.0001	Electrical Permits	5,000		0	5,000	5,890	0		117.80
0010.00.00.3230.0002	Plumbing Permits	2,500		0	2,500	4,828	0		193.12
0010.00.00.3230.0003	Gas Permits	2,500		0	2,500	450	0		18.00
0010.00.00.3230.0004	Building Permits	110,000		0	110,000	95,832	0		87.12
0010.00.00.3230.0005	Yard Sale Permits	50		0	50	15	0		30.00
0010.00.00.3230.0006	Mobile Home Permits	1,500		0	1,500	1,080	0		72.00
0010.00.00.3230.0007	Demolition & Clearance	2,000		0	2,000	1,200	0		60.00
0010.00.00.3230.0008	Mechanical Permits	6,000		0	6,000	5,665	0		94.42
0010.00.00.3230.0010	Bus Lic Inspection Fee	50		0	50	741	0		1,482.00
0010.00.00.3230.0013	Burning Permit	50		0	50	0	0		0.00
0010.00.00.3230.0014	Construct Parking Permit	500		0	500	160	0		32.00
0010.00.00.3230.0015	Reinspection Fee	4,000		0	4,000	0	0		0.00
0010.00.00.3230.0016	Permit Not Posted On-Site	50		0	50	0	0		0.00
0010.00.00.3230.0019	Stop Work Order Fee	1,300		0	1,300	1,547	0		119.00
0010.00.00.3230.0020	Board of Appeals Fee	600		0	600	1,800	0		300.00
0010.00.00.3230.0021	Zoning Fees	7,500		0	7,500	9,475	0		126.33
0010.00.00.3230.0022	Plan Review Fee	50,000		0	50,000	46,638	0		93.28
0010.00.00.3230.0023	Sign Permit Fee	7,000		0	7,000	2,000	0		28.57
0010.00.00.3230.0024	Planning Commission Fees	500		0	500	600	0		120.00
0010.00.00.3230.0025	ARB Fees	6,000		0	6,000	4,900	0		81.67
0010.00.00.3230.0026	Plat Approval Fees	600		0	600	0	0		0.00
0010.00.00.3230.0027	Special Events Permit	2,500		0	2,500	6,451	0		258.04
0010.00.00.3230.0028	Miscellaneous permits	4,000		0	4,000	275	0		6.88
0010.00.00.3230.0029	STR Permits	5,000		0	5,000	4,000	0		80.00
0010.00.00.3230.0030	Community Appearance Board Appli	300		0	300	800	0		266.67
0010.00.00.3240.0008	Fire Impact Fee	45,000		0	45,000	41,303	0		91.78
0010.00.00.3320.0000	State Grants	286,171		0	286,171	68,129	0		23.81
0010.00.00.3350.0001	Local Government Fund	196,933		0	196,933	170,932	0		86.80
0010.00.00.3420.0005	Fire Prevention Donations	0		0	0	250	0		0.00
0010.00.00.3440.0005	SRO Reimbursement	178,000		0	178,000	0	0		0.00
0010.00.00.3510.0001	Police Fines	75,000		0	75,000	11,460	0		15.28
0010.00.00.3510.0003	Parking Fines	25,000		0	25,000	35,895	0		143.58
0010.00.00.3510.0007	Sunday Liquor Sales	12,000		0	12,000	13,100	0		109.17
0010.00.00.3510.0008	Victim's Asst. Fees-(%)	6,500		0	6,500	1,538	0		23.66
0010.00.00.3510.0009	Victim's Asst. Flat Fees	2,500		0	2,500	367	0		14.68
0010.00.00.3510.0010	Misc Police Revenue	5,000		0	5,000	16,191	0		323.82

BUDGET REPORT FOR CITY OF GEORGETOWN, SC
Calculations As of 01/31/2026

GL Number	Description	Original	25-26 Budget	25-26 Amended Amt Change	25-26 Budget	25-26 Activity	25-26 Encumbrance	% Budget	25-26 Used
Fund: 0010 General Fund									
Account Category: Estimated Revenues									
0010.00.00.3610.0001	Investment Earnings	225,000		0	225,000	176,354	0		78.38
0010.00.00.3620.0000	Rents and Royalties	12,000		0	12,000	17,372	0		144.77
0010.00.00.3630.0001	Fees for GIS/B&P Documents	50		0	50	0	0		0.00
0010.00.00.3630.0005	FOIA Fees	650		0	650	55	0		8.46
0010.00.00.3640.0000	Housing Authority FILOT	45,000		0	45,000	0	0		0.00
0010.00.00.3640.0001	Steel Mill FILOT	5,000		0	5,000	0	0		0.00
0010.00.00.3670.0007	Donations and Promotions-Police	0		0	0	3,369	0		0.00
0010.00.00.3680.0000	Work Comp Reimbursement	41,099		0	41,099	43,200	0		105.11
0010.00.00.3690.0000	Cash Over & Short	0		0	0	(200)	0		0.00
0010.00.00.3690.0002	Miscellaneous Revenue	15,000		0	15,000	24,943	0		166.29
0010.00.00.3690.0003	Insurance Proceeds	15,000		0	15,000	16,171	0		107.81
0010.00.00.3690.0005	Set-off Debt Collection Fees	500		0	500	933	0		186.60
0010.00.00.3690.0013	Returned Check Fees	2,500		0	2,500	0	0		0.00
0010.00.00.3700.0000	Overpayments	0		0	0	831	0		0.00
0010.00.00.3910.0001	Sale of Assets	0		0	0	140,777	0		0.00
0010.00.00.3920.0001	From Electric Fund	918,371		0	918,371	535,716	0		58.33
0010.00.00.3920.0002	From Water Fund	357,431		0	357,431	208,501	0		58.33
0010.00.00.3920.0003	From Accom Tax Fund	32,250		0	32,250	28,936	0		89.72
0010.00.00.3920.0005	From Wastewater Fund	395,802		0	395,802	230,885	0		58.33
0010.00.00.3920.0009	From Hospitality Fund	125,000		0	125,000	72,917	0		58.33
0010.00.00.3930.0004	Bond Proceeds	0		0	0	3,995,100	0		0.00
0010.00.00.3940.0002	Transfer from fund balance	579,913		0	579,913	0	0		0.00
	Estimated Revenues	15,118,937		0	15,118,937	7,082,187	0		46.84
Account Category: Appropriations									
0010.01.00.4000.0101	Regular Pay	432,000		0	432,000	253,526	0		58.69
0010.01.00.4010.0103	Overtime	1,700		0	1,700	2,176	0		128.00
0010.01.00.4050.0114	FICA	33,250		0	33,250	18,638	0		56.05
0010.01.00.4060.0116	Retirement	81,750		0	81,750	46,955	0		57.44
0010.01.00.4080.0125	SCMIT Worker's Comp Ins.	10,489		0	10,489	8,914	0		84.98
0010.01.00.4100.0001	Health Claims Cost	34,026		0	34,026	71,779	0		210.95
0010.01.00.4100.0002	Health Claim Costs-Retire	9,472		0	9,472	8,387	0		88.55
0010.01.00.5000.0101	Supplies and Materials	5,000		0	5,000	1,973	0		39.46
0010.01.00.5000.0102	Equipment	200		0	200	0	0		0.00
0010.01.00.5000.0105	Printing and Binding	300		0	300	0	0		0.00
0010.01.00.6100.0111	Communications- Landline	5,000		0	5,000	2,603	0		52.06
0010.01.00.6100.0112	Postage	500		0	500	90	0		18.00
0010.01.00.6100.1110	Communications- Wireless	1,500		0	1,500	559	0		37.27
0010.01.00.6200.0114	Advertising	0		0	0	615	0		100.00
0010.01.00.6400.0124	Travel Expense	5,400		0	5,400	407	0		7.54
0010.01.00.6500.0127	Electricity	3,798		0	3,798	2,429	0		63.95
0010.01.00.6500.0128	Water	925		0	925	750	0		81.08
0010.01.00.6500.0129	Wastewater	865		0	865	436	0		50.40
0010.01.00.6500.0130	Sanitation	1,054		0	1,054	597	0		56.64
0010.01.00.6500.0133	Stormwater	1,489		0	1,489	843	0		56.62
0010.01.00.6500.0134	Security Lights	1,947		0	1,947	1,103	0		56.65
0010.01.00.6500.1271	Electricity- Sales Tax	125		0	125	97	0		77.60
0010.01.00.6600.0139	Fleet Services-RTA Mtce Allocati	75		0	75	0	0		0.00
0010.01.00.6600.0145	Gasoline & Oil	700		0	700	325	0		46.43
0010.01.00.6600.1391	Fleet Services -Departmental Exp	708		0	708	393	0		55.51

BUDGET REPORT FOR CITY OF GEORGETOWN, SC
Calculations As of 01/31/2026

GL Number	Description	Original	25-26 Budget	25-26 Amended Budget	25-26 Amended Budget	25-26 Activity	25-26 Encumbrance	% Budget	25-26 Used
Fund: 0010 General Fund									
Account Category: Appropriations									
0010.01.00.6700.0156	Equipment Rental/Lease		5,900	0	5,900	1,718	0		29.12
0010.01.00.6850.0180	Membership Dues and Fees		2,874	0	2,874	1,183	0		41.16
0010.01.00.6850.0182	Other Operating Expenses		3,000	0	3,000	2,164	0		72.13
0010.01.00.6850.0186	Training		6,090	0	6,090	2,302	0		37.80
0010.01.00.6850.1801	Subscriptions		425	0	425	200	0		47.06
0010.01.00.6860.0187	Professional Services		5,000	0	5,000	11,100	1,197		222.00
0010.01.00.6860.0195	Repair/Maint Svc Contract		900	0	900	628	0		69.78
0010.01.00.6860.1895	Employee wellness services		3,009	0	3,009	1,110	0		36.89
0010.01.00.6870.0204	Janitorial Services		6,729	0	6,729	1,120	560		16.64
0010.01.00.7950.0001	IT Internal Allocations		42,428	0	42,428	23,722	0		55.91
0010.01.00.7950.0995	GF Cost Distribution	(406,432)	0	0	(406,432)	(237,085)	0		58.33
0010.01.02.4000.0101	Regular Pay		116,000	0	116,000	76,445	0		65.90
0010.01.02.4050.0114	FICA		8,900	0	8,900	5,148	0		57.84
0010.01.02.4060.0116	Retirement		22,000	0	22,000	10,446	0		47.48
0010.01.02.4100.0001	Health Claims Cost		38,187	0	38,187	64,624	0		169.23
0010.01.02.4100.0002	Health Claim Costs-Retire		2,253	0	2,253	0	0		0.00
0010.01.02.5000.0101	Supplies and Materials		2,000	0	2,000	567	0		28.35
0010.01.02.5000.0102	Equipment		1,600	0	1,600	0	0		0.00
0010.01.02.5000.0105	Printing and Binding		600	0	600	0	0		0.00
0010.01.02.6100.0111	Communications- Landline		50	0	50	0	0		0.00
0010.01.02.6100.0112	Postage		400	0	400	47	0		11.75
0010.01.02.6100.1110	Communications- Wireless		5,000	0	5,000	2,007	0		40.14
0010.01.02.6200.0114	Advertising		3,000	0	3,000	84	0		2.80
0010.01.02.6400.0124	Travel Expense		20,450	0	20,450	4,460	0		21.81
0010.01.02.6700.0156	Equipment Rental/Lease		11,000	0	11,000	0	0		0.00
0010.01.02.6850.0180	Membership Dues and Fees		0	0	0	495	0		100.00
0010.01.02.6850.0182	Other Operating Expenses		5,000	0	5,000	93	0		1.86
0010.01.02.6850.0186	Training		14,255	0	14,255	1,930	0		13.54
0010.01.02.6860.0187	Professional Services		350	0	350	0	0		0.00
0010.01.02.6860.1895	Employee wellness services		11,004	0	11,004	3,902	0		35.46
0010.01.02.7950.0001	IT Internal Allocations		48,488	0	48,488	29,950	0		61.77
0010.04.00.4000.0101	Regular Pay		762,000	0	762,000	415,121	0		54.48
0010.04.00.4010.0103	Overtime		5,000	0	5,000	699	0		13.98
0010.04.00.4010.0106	Contract Labor		15,000	0	15,000	4,039	0		26.93
0010.04.00.4050.0114	FICA		60,500	0	60,500	30,590	0		50.56
0010.04.00.4060.0116	Retirement		145,500	0	145,500	76,184	0		52.36
0010.04.00.4080.0125	SCMIT Worker's Comp Ins.		5,760	0	5,760	4,656	0		80.83
0010.04.00.4100.0001	Health Claims Cost		63,514	0	63,514	114,550	0		180.35
0010.04.00.4100.0002	Health Claim Costs-Retire		2,253	0	2,253	315	0		13.98
0010.04.00.5000.0101	Supplies and Materials		0	0	0	2,257	0		100.00
0010.04.00.5000.0105	Printing and Binding		600	0	600	0	0		0.00
0010.04.00.6100.0111	Communications- Landline		1,500	0	1,500	511	0		34.07
0010.04.00.6100.0112	Postage		7,500	0	7,500	4,385	0		58.47
0010.04.00.6100.1110	Communications- Wireless		500	0	500	238	0		47.60
0010.04.00.6400.0124	Travel Expense		5,000	0	5,000	4,200	0		84.00
0010.04.00.6500.0127	Electricity		3,021	0	3,021	1,821	0		60.28
0010.04.00.6500.0128	Water		792	0	792	643	0		81.19
0010.04.00.6500.0129	Wastewater		742	0	742	374	0		50.40
0010.04.00.6500.0130	Sanitation		903	0	903	511	0		56.59

BUDGET REPORT FOR CITY OF GEORGETOWN, SC
Calculations As of 01/31/2026

GL Number	Description	Original	25-26 Budget	25-26 Amended Amt Change	25-26 Budget	25-26 Activity	25-26 Encumbrance	% Budget	25-26 Used
Fund: 0010 General Fund									
Account Category: Appropriations									
0010.04.00.6500.0133	Stormwater		1,230	0	1,230	697	0		56.67
0010.04.00.6500.0134	Security Lights		1,669	0	1,669	945	0		56.62
0010.04.00.6500.1271	Electricity- Sales Tax		107	0	107	83	0		77.57
0010.04.00.6700.0156	Equipment Rental/Lease		10,761	0	10,761	2,998	0		27.86
0010.04.00.6850.0180	Membership Dues and Fees		2,000	0	2,000	734	0		36.70
0010.04.00.6850.0182	Other Operating Expenses		3,000	0	3,000	5,450	0		181.67
0010.04.00.6850.0184	Continuing Education		1,600	0	1,600	510	0		31.88
0010.04.00.6850.0186	Training		3,250	0	3,250	2,669	0		82.12
0010.04.00.6860.0189	Employee Medical		650	0	650	0	0		0.00
0010.04.00.6860.1895	Employee wellness services		10,007	0	10,007	3,553	0		35.51
0010.04.00.6870.0202	Utility Billing Services		0	0	0	945	0		100.00
0010.04.00.6870.0204	Janitorial Services		0	0	0	61	0		100.00
0010.04.00.7950.0001	IT Internal Allocations		42,428	0	42,428	26,142	0		61.61
0010.04.00.7950.0995	GF Cost Distribution		(462,220)	0	(462,220)	(269,628)	0		58.33
0010.05.05.4000.0101	Regular Pay		3,042,520	0	3,042,520	1,533,462	0		50.40
0010.05.05.4010.0103	Overtime		166,014	0	166,014	120,774	0		72.75
0010.05.05.4010.0105	On-call pay		12,000	0	12,000	5,986	0		49.88
0010.05.05.4050.0114	FICA		241,500	0	241,500	121,521	0		50.32
0010.05.05.4060.0116	Retirement		670,000	0	670,000	345,070	0		51.50
0010.05.05.4080.0125	SCMIT Worker's Comp Ins.		143,538	0	143,538	101,050	0		70.40
0010.05.05.4100.0001	Health Claims Cost		311,286	0	311,286	468,210	0		150.41
0010.05.05.4100.0002	Health Claim Costs-Retire		65,871	0	65,871	50,618	0		76.84
0010.05.05.5000.0101	Supplies and Materials		27,255	0	27,255	18,972	0		69.61
0010.05.05.5000.0102	Equipment		25,463	0	25,463	16,861	0		66.22
0010.05.05.5000.0103	Furniture		7,384	0	7,384	44	0		0.60
0010.05.05.5000.0108	SRO Grant Expenses		34,560	0	34,560	2,537	0		7.34
0010.05.05.5010.0101	Uniforms and Clothing		63,130	0	63,130	27,734	0		43.93
0010.05.05.6100.0111	Communications- Landline		12,412	0	12,412	880	0		7.09
0010.05.05.6100.0112	Postage		515	0	515	171	0		33.20
0010.05.05.6100.1110	Communications- Wireless		62,814	0	62,814	41,604	6,718		66.23
0010.05.05.6200.0114	Advertising		3,045	0	3,045	0	0		0.00
0010.05.05.6400.0124	Travel Expense		23,336	0	23,336	4,575	0		19.60
0010.05.05.6500.0127	Electricity		37,455	0	37,455	19,568	0		52.24
0010.05.05.6500.0128	Water		4,545	0	4,545	2,325	0		51.16
0010.05.05.6500.0129	Wastewater		3,416	0	3,416	1,756	0		51.41
0010.05.05.6500.0130	Sanitation		2,255	0	2,255	1,277	0		56.63
0010.05.05.6500.0133	Stormwater		2,235	0	2,235	1,266	0		56.64
0010.05.05.6500.0134	Security Lights		3,830	0	3,830	2,169	0		56.63
0010.05.05.6500.1271	Electricity- Sales Tax		961	0	961	798	0		83.04
0010.05.05.6600.0103	Emergency Preparedness		5,000	0	5,000	4,375	0		87.50
0010.05.05.6600.0133	Repairs & Maint. Services		40,690	0	40,690	12,453	0		30.60
0010.05.05.6600.0139	Fleet Services-RTA Mtce Allocati		33,166	0	33,166	20,809	0		62.74
0010.05.05.6600.0145	Gasoline & Oil		119,000	0	119,000	57,224	0		48.09
0010.05.05.6600.1391	Fleet Services -Departmental Exp		58,222	0	58,222	39,268	0		67.45
0010.05.05.6600.1392	Fleet Svcs- Outside Vends		26,400	0	26,400	7,639	0		28.94
0010.05.05.6700.0156	Equipment Rental/Lease		7,725	0	7,725	2,860	0		37.02
0010.05.05.6820.1721	Prisoner Housing		70,000	0	70,000	54,953	0		78.50
0010.05.05.6850.0180	Membership Dues and Fees		4,583	0	4,583	2,820	0		61.53
0010.05.05.6850.0182	Other Operating Expenses		12,314	0	12,314	2,045	0		16.61

BUDGET REPORT FOR CITY OF GEORGETOWN, SC
Calculations As of 01/31/2026

GL Number	Description	Original	25-26 Budget	25-26 Amended Amt Change	25-26 Budget	25-26 Activity	25-26 Encumbrance	% Budget	25-26 Used
Fund: 0010 General Fund									
Account Category: Appropriations									
0010.05.05.6850.0184	Continuing Education		3,000	0	3,000	0	0		0.00
0010.05.05.6850.0186	Training		13,220	0	13,220	3,358	0		25.40
0010.05.05.6850.0187	Special Projects		7,496	0	7,496	1,314	0		17.53
0010.05.05.6850.0189	Reserve Program		3,030	0	3,030	0	0		0.00
0010.05.05.6850.1801	Subscriptions		11,728	0	11,728	7,384	0		62.96
0010.05.05.6850.1861	Law Enforce Accreditation/Policy		12,545	0	12,545	7,880	0		62.81
0010.05.05.6860.0184	Technology Services		45,625	0	45,625	41,479	0		90.91
0010.05.05.6860.0189	Employee Medical		2,859	0	2,859	809	0		28.30
0010.05.05.6860.0194	Other Prof/Tech Services		85,000	0	85,000	0	85,000		0.00
0010.05.05.6860.0195	Repair/Maint Svc Contract		38,522	0	38,522	4,723	0		12.26
0010.05.05.6860.1895	Employee wellness services		36,021	0	36,021	12,285	0		34.11
0010.05.05.6870.0203	Contract Services		8,755	0	8,755	(730)	0		(8.34)
0010.05.05.6870.0204	Janitorial Services		6,729	0	6,729	10,800	5,400		160.50
0010.05.05.7950.0001	IT Internal Allocations		42,428	0	42,428	26,206	0		61.77
0010.05.05.7950.0010	911 Expense Billing		(1,888)	0	(1,888)	0	0		0.00
0010.05.07.4000.0101	Regular Pay		45,300	0	45,300	25,630	0		56.58
0010.05.07.4010.0103	Overtime		2,760	0	2,760	145	0		5.25
0010.05.07.4050.0114	FICA		3,680	0	3,680	1,926	0		52.34
0010.05.07.4060.0116	Retirement		8,920	0	8,920	4,701	0		52.70
0010.05.07.4080.0125	SCMIT Worker's Comp Ins.		1,305	0	1,305	758	0		58.08
0010.05.07.4100.0001	Health Claims Cost		0	0	0	1,921	0		100.00
0010.05.07.5000.0101	Supplies and Materials		1,083	0	1,083	94	0		8.68
0010.05.07.5000.0102	Equipment		1,417	0	1,417	0	0		0.00
0010.05.07.5010.0101	Uniforms and Clothing		412	0	412	0	0		0.00
0010.05.07.6100.0111	Communications- Landline		310	0	310	0	0		0.00
0010.05.07.6100.0112	Postage		155	0	155	0	0		0.00
0010.05.07.6100.1110	Communications- Wireless		2,082	0	2,082	780	0		37.46
0010.05.07.6400.0124	Travel Expense		1,875	0	1,875	368	0		19.63
0010.05.07.6600.0133	Repairs & Maint. Services		3,500	0	3,500	0	0		0.00
0010.05.07.6600.0134	Radio Repairs		670	0	670	0	0		0.00
0010.05.07.6600.0139	Fleet Services-RTA Mtce Allocati		206	0	206	0	0		0.00
0010.05.07.6600.0145	Gasoline & Oil		3,605	0	3,605	536	0		14.87
0010.05.07.6600.1391	Fleet Services -Departmental Exp		1,061	0	1,061	492	0		46.37
0010.05.07.6600.1392	Fleet Svcs- Outside vends		650	0	650	0	0		0.00
0010.05.07.6700.0156	Equipment Rental/Lease		260	0	260	0	0		0.00
0010.05.07.6850.0180	Membership Dues and Fees		335	0	335	0	0		0.00
0010.05.07.6850.0182	Other Operating Expenses		1,340	0	1,340	307	0		22.91
0010.05.07.6850.0186	Training		1,200	0	1,200	85	0		7.08
0010.05.07.6850.0187	Special Projects		375	0	375	324	0		86.40
0010.05.07.6860.0195	Repair/Maint Svc Contract		670	0	670	0	0		0.00
0010.05.07.6860.1895	Employee wellness services		1,200	0	1,200	408	0		34.00
0010.05.07.7950.0001	IT Internal Allocations		6,061	0	6,061	3,744	0		61.77
0010.05.26.6600.0139	Fleet Services-RTA Mtce Allocati		750	0	750	655	0		87.33
0010.05.26.6600.1391	Fleet Services -Departmental Exp		1,309	0	1,309	1,225	0		93.58
0010.05.26.6600.1392	Fleet Svcs- Outside Vends		0	0	0	3,589	0		100.00
0010.05.26.6850.0182	Other Operating Expenses		0	0	0	537	0		100.00
0010.06.00.4080.0125	SCMIT Worker's Comp Ins.		0	0	0	1,516	0		100.00
0010.06.00.6500.0130	Sanitation		0	0	0	24	0		100.00
0010.06.00.6500.0133	Stormwater		0	0	0	34	0		100.00

BUDGET REPORT FOR CITY OF GEORGETOWN, SC
Calculations As of 01/31/2026

GL Number	Description	Original	25-26 Budget	25-26 Amended Budget	25-26 Amended Budget	25-26 Activity	25-26 Encumbrance	% Budget	25-26 Used
Fund: 0010 General Fund									
Account Category: Appropriations									
0010.06.00.6500.0134	Security Lights		0	0	0	45	0		100.00
0010.09.00.4000.0101	Regular Pay	667,670		0	667,670	247,521	0		37.07
0010.09.00.4010.0103	Overtime	4,500		0	4,500	1,541	0		34.24
0010.09.00.4010.0106	Contract Labor	50,000		0	50,000	12,280	13,320		24.56
0010.09.00.4050.0114	FICA	51,500		0	51,500	18,367	0		35.66
0010.09.00.4060.0116	Retirement	124,800		0	124,800	45,817	0		36.71
0010.09.00.4080.0125	SCMIT Worker's Comp Ins.	5,209		0	5,209	1,484	0		28.49
0010.09.00.4100.0001	Health Claims Cost	59,472		0	59,472	64,580	0		108.59
0010.09.00.5000.0101	Supplies and Materials	4,395		0	4,395	1,074	0		24.44
0010.09.00.5000.0102	Equipment	2,300		0	2,300	0	0		0.00
0010.09.00.5000.0103	Furniture	500		0	500	0	0		0.00
0010.09.00.5000.0105	Printing and Binding	1,820		0	1,820	0	0		0.00
0010.09.00.5150.0124	Department Supplies	300		0	300	0	0		0.00
0010.09.00.6100.0111	Communications- Landline	1,200		0	1,200	511	0		42.58
0010.09.00.6100.0112	Postage	4,368		0	4,368	1,150	0		26.33
0010.09.00.6100.1110	Communications- Wireless	3,000		0	3,000	2,087	0		69.57
0010.09.00.6200.0114	Advertising	4,590		0	4,590	1,706	0		37.17
0010.09.00.6400.0124	Travel Expense	9,020		0	9,020	1,333	0		14.78
0010.09.00.6500.0127	Electricity	2,500		0	2,500	1,214	0		48.56
0010.09.00.6500.0128	Water	529		0	529	428	0		80.91
0010.09.00.6500.0129	Wastewater	475		0	475	249	0		52.42
0010.09.00.6500.0130	Sanitation	620		0	620	317	0		51.13
0010.09.00.6500.0133	Stormwater	875		0	875	443	0		50.63
0010.09.00.6500.0134	Security Lights	1,115		0	1,115	585	0		52.47
0010.09.00.6500.1271	Electricity- Sales Tax	300		0	300	55	0		18.33
0010.09.00.6600.0133	Repairs & Maint. Services	465		0	465	0	0		0.00
0010.09.00.6600.0139	Fleet Services-RTA Mtce Allocati	1,500		0	1,500	89	0		5.93
0010.09.00.6600.0145	Gasoline & Oil	6,867		0	6,867	1,617	0		23.55
0010.09.00.6600.1391	Fleet Services -Departmental Exp	2,335		0	2,335	1,294	0		55.42
0010.09.00.6600.1392	Fleet Svcs- Outside Vends	750		0	750	0	0		0.00
0010.09.00.6700.0156	Equipment Rental/Lease	7,500		0	7,500	2,267	0		30.23
0010.09.00.6850.0180	Membership Dues and Fees	2,900		0	2,900	1,816	0		62.62
0010.09.00.6850.0182	Other Operating Expenses	755		0	755	402	0		53.25
0010.09.00.6850.0184	Continuing Education	4,947		0	4,947	1,194	0		24.14
0010.09.00.6850.0186	Training	6,396		0	6,396	1,555	0		24.31
0010.09.00.6850.0192	KGB Operations	0		0	0	(167)	0		0.00
0010.09.00.6860.0186	Legal Services	200		0	200	1,099	0		549.50
0010.09.00.6860.0187	Professional Services	350		0	350	0	0		0.00
0010.09.00.6860.0191	Contract Services/Studies	271,000		0	271,000	34,740	0		12.82
0010.09.00.6860.0201	Main Street Coordinator Operatin	11,200		0	11,200	3,229	0		28.83
0010.09.00.6860.1895	Employee wellness services	5,004		0	5,004	1,806	0		36.09
0010.09.00.7950.0001	IT Internal Allocations	18,184		0	18,184	11,231	0		61.76
0010.10.00.4000.0101	Regular Pay	217,000		0	217,000	109,901	0		50.65
0010.10.00.4010.0103	Overtime	5,500		0	5,500	4,328	0		78.69
0010.10.00.4010.0105	On-call pay	10,400		0	10,400	5,586	0		53.71
0010.10.00.4050.0114	FICA	18,000		0	18,000	8,927	0		49.59
0010.10.00.4060.0116	Retirement	44,000		0	44,000	21,726	0		49.38
0010.10.00.4080.0125	SCMIT Worker's Comp Ins.	3,139		0	3,139	1,863	0		59.35
0010.10.00.4100.0001	Health Claims Cost	14,453		0	14,453	16,026	0		110.88

BUDGET REPORT FOR CITY OF GEORGETOWN, SC
Calculations As of 01/31/2026

GL Number	Description	Original	25-26 Budget	25-26 Amended Amt Change	25-26 Budget	25-26 Activity	25-26 Encumbrance	% Budget	25-26 Used
Fund: 0010 General Fund									
Account Category: Appropriations									
0010.10.00.5000.0101	Supplies and Materials		3,500	0	3,500	1,232	0		35.20
0010.10.00.5000.0102	Equipment		1,500	0	1,500	0	0		0.00
0010.10.00.6100.0111	Communications- Landline		1,600	0	1,600	908	0		56.75
0010.10.00.6100.0112	Postage		4,700	0	4,700	2,923	0		62.19
0010.10.00.6200.0114	Advertising		500	0	500	0	0		0.00
0010.10.00.6400.0124	Travel Expense		900	0	900	0	0		0.00
0010.10.00.6500.0127	Electricity		6,965	0	6,965	3,639	0		52.25
0010.10.00.6500.0128	Water		693	0	693	354	0		51.08
0010.10.00.6500.0129	Wastewater		521	0	521	268	0		51.44
0010.10.00.6500.0130	Sanitation		120	0	120	68	0		56.67
0010.10.00.6500.0133	Stormwater		389	0	389	220	0		56.56
0010.10.00.6500.0134	Security Lights		471	0	471	267	0		56.69
0010.10.00.6500.1271	Electricity- Sales Tax		179	0	179	148	0		82.68
0010.10.00.6600.0133	Repairs & Maint. Services		2,500	0	2,500	2,222	0		88.88
0010.10.00.6600.0139	Fleet Services-RTA Mtce Allocati		500	0	500	0	0		0.00
0010.10.00.6600.0145	Gasoline & Oil		350	0	350	197	0		56.29
0010.10.00.6600.1391	Fleet Services -Departmental Exp		708	0	708	328	0		46.33
0010.10.00.6700.0156	Equipment Rental/Lease		2,400	0	2,400	1,275	0		53.13
0010.10.00.6850.0180	Membership Dues and Fees		120	0	120	110	0		91.67
0010.10.00.6850.0182	Other Operating Expenses		4,135	0	4,135	2,532	0		61.23
0010.10.00.6850.0186	Training		400	0	400	0	0		0.00
0010.10.00.6860.0187	Professional Services		39,375	0	39,375	21,494	12,000		54.59
0010.10.00.6860.0195	Repair/Maint Svc Contract		2,000	0	2,000	1,474	0		73.70
0010.10.00.6860.1895	Employee wellness services		3,009	0	3,009	1,108	0		36.82
0010.10.00.7950.0001	IT Internal Allocations		30,306	0	30,306	18,719	0		61.77
0010.11.00.4000.0101	Regular Pay		2,105,000	0	2,105,000	940,812	0		44.69
0010.11.00.4010.0103	Overtime		225,000	0	225,000	138,612	0		61.61
0010.11.00.4020.0111	Volunteer Employees		500	0	500	255	0		51.00
0010.11.00.4050.0114	FICA		177,750	0	177,750	78,808	0		44.34
0010.11.00.4060.0116	Retirement		493,500	0	493,500	216,323	0		43.83
0010.11.00.4080.0125	SCMIT Worker's Comp Ins.		78,232	0	78,232	52,938	0		67.67
0010.11.00.4100.0001	Health Claims Cost		297,498	0	297,498	335,669	0		112.83
0010.11.00.4100.0002	Health Claim Costs-Retire		42,736	0	42,736	30,952	0		72.43
0010.11.00.5000.0101	Supplies and Materials		25,000	0	25,000	15,440	0		61.76
0010.11.00.5000.0102	Equipment		53,250	0	53,250	17,752	0		33.34
0010.11.00.5000.0103	Furniture		7,000	0	7,000	2,391	0		34.16
0010.11.00.5000.0105	Printing and Binding		500	0	500	546	0		109.20
0010.11.00.5000.0107	Technology Supplies		14,197	0	14,197	6,659	0		46.90
0010.11.00.5010.0101	Uniforms and Clothing		68,700	0	68,700	5,343	22,203		7.78
0010.11.00.5150.0121	Safety Supplies		10,000	0	10,000	2,743	0		27.43
0010.11.00.5150.0128	Medical Supplies		20,000	0	20,000	3,783	0		18.92
0010.11.00.5310.0140	Haz Mat Supplies/Equipmnt		12,000	0	12,000	523	0		4.36
0010.11.00.6100.0111	Communications- Landline		6,500	0	6,500	2,388	0		36.74
0010.11.00.6100.0112	Postage		1,000	0	1,000	77	0		7.70
0010.11.00.6100.1110	Communications- Wireless		33,000	0	33,000	17,701	0		53.64
0010.11.00.6200.0114	Advertising		750	0	750	0	0		0.00
0010.11.00.6300.0121	Fire Prevention Materials		12,500	0	12,500	4,156	0		33.25
0010.11.00.6400.0124	Travel Expense		6,006	0	6,006	2,299	0		38.28
0010.11.00.6500.0127	Electricity		12,463	0	12,463	10,511	0		84.34

BUDGET REPORT FOR CITY OF GEORGETOWN, SC
Calculations As of 01/31/2026

GL Number	Description	Original	25-26 Budget	25-26 Amended Amt Change	25-26 Budget	25-26 Activity	25-26 Encumbrance	% Budget	25-26 Used
Fund: 0010 General Fund									
Account Category: Appropriations									
0010.11.00.6500.0128	Water		6,118	0	6,118	2,947	0		48.17
0010.11.00.6500.0129	Wastewater		3,462	0	3,462	1,557	0		44.97
0010.11.00.6500.0130	Sanitation		973	0	973	551	0		56.63
0010.11.00.6500.0133	Stormwater		2,341	0	2,341	1,326	0		56.64
0010.11.00.6500.0134	Security Lights		1,866	0	1,866	1,057	0		56.65
0010.11.00.6500.1271	Electricity- Sales Tax		393	0	393	264	0		67.18
0010.11.00.6600.0103	Emergency Preparedness		5,000	0	5,000	0	0		0.00
0010.11.00.6600.0105	COVID-19 Pandemic Expense		2,000	0	2,000	0	0		0.00
0010.11.00.6600.0133	Repairs & Maint. Services		38,000	0	38,000	10,850	0		28.55
0010.11.00.6600.0139	Fleet Services-RTA Mtce Allocati		25,000	0	25,000	19,897	0		79.59
0010.11.00.6600.0145	Gasoline & Oil		45,000	0	45,000	16,391	0		36.42
0010.11.00.6600.1391	Fleet Services -Departmental Exp		16,165	0	16,165	12,179	0		75.34
0010.11.00.6600.1392	Fleet Svcs- Outside Vends		40,000	0	40,000	40,360	32,030		100.90
0010.11.00.6700.0156	Equipment Rental/Lease		8,500	0	8,500	3,366	0		39.60
0010.11.00.6820.0169	Laundry & Linen		2,000	0	2,000	483	0		24.15
0010.11.00.6850.0180	Membership Dues and Fees		2,218	0	2,218	645	0		29.08
0010.11.00.6850.0182	Other Operating Expenses		3,000	0	3,000	1,957	0		65.23
0010.11.00.6850.0184	Continuing Education		3,000	0	3,000	751	0		25.03
0010.11.00.6850.0186	Training		19,890	0	19,890	8,869	0		44.59
0010.11.00.6850.0187	Special Projects		25,700	0	25,700	169	0		0.66
0010.11.00.6850.1801	Subscriptions		14,423	0	14,423	15,009	0		104.06
0010.11.00.6860.0189	Employee Medical		13,800	0	13,800	3,800	0		27.54
0010.11.00.6860.0195	Repair/Maint Svc Contract		89,336	0	89,336	41,711	0		46.69
0010.11.00.6860.1895	Employee wellness services		30,004	0	30,004	10,538	0		35.12
0010.11.00.7950.0001	IT Internal Allocations		36,367	0	36,367	22,463	0		61.77
0010.12.00.4000.0101	Regular Pay		578,000	0	578,000	400,198	0		69.24
0010.12.00.4010.0103	Overtime		25,000	0	25,000	6,864	0		27.46
0010.12.00.4010.0106	Contract Labor		25,000	0	25,000	22,491	0		89.96
0010.12.00.4050.0114	FICA		48,500	0	48,500	29,772	0		61.39
0010.12.00.4060.0116	Retirement		117,000	0	117,000	74,405	0		63.59
0010.12.00.4080.0125	SCMIT Worker's Comp Ins.		35,434	0	35,434	25,004	0		70.56
0010.12.00.4100.0001	Health Claims Cost		97,383	0	97,383	124,116	0		127.45
0010.12.00.4100.0002	Health Claim Costs-Retire		34,714	0	34,714	24,189	0		69.68
0010.12.00.5000.0101	Supplies and Materials		6,000	0	6,000	6,152	0		102.53
0010.12.00.5000.0102	Equipment		17,400	0	17,400	12,469	0		71.66
0010.12.00.5000.0105	Printing and Binding		1,500	0	1,500	0	0		0.00
0010.12.00.5010.0101	Uniforms and Clothing		18,500	0	18,500	7,292	0		39.42
0010.12.00.5130.0112	Asphalt/Concrete/Gravel		17,500	0	17,500	13,030	0		74.46
0010.12.00.5150.0121	Safety Supplies		5,500	0	5,500	3,797	0		69.04
0010.12.00.6100.0111	Communications- Landline		3,500	0	3,500	2,108	0		60.23
0010.12.00.6100.0112	Postage		400	0	400	116	0		29.00
0010.12.00.6100.1110	Communications- Wireless		5,000	0	5,000	2,554	0		51.08
0010.12.00.6200.0114	Advertising		150	0	150	0	0		0.00
0010.12.00.6400.0124	Travel Expense		2,500	0	2,500	1,192	0		47.68
0010.12.00.6500.0127	Electricity		1,040	0	1,040	965	0		92.79
0010.12.00.6500.0128	Water		1,311	0	1,311	607	0		46.30
0010.12.00.6500.0129	Wastewater		1,330	0	1,330	619	0		46.54
0010.12.00.6500.0130	Sanitation		470	0	470	266	0		56.60
0010.12.00.6500.0133	Stormwater		668	0	668	378	0		56.59

BUDGET REPORT FOR CITY OF GEORGETOWN, SC
Calculations As of 01/31/2026

GL Number	Description	Original	25-26 Budget	25-26 Amended Amt Change	25-26 Budget	25-26 Activity	25-26 Encumbrance	% Budget	25-26 Used
Fund: 0010 General Fund									
Account Category: Appropriations									
0010.12.00.6500.0134	Security Lights		550	0	550	312	0		56.73
0010.12.00.6500.1271	Electricity- Sales Tax		2	0	2	2	0		100.00
0010.12.00.6600.0103	Emergency Preparedness		7,000	0	7,000	550	0		7.86
0010.12.00.6600.0133	Repairs & Maint. Services		15,000	0	15,000	10,227	0		68.18
0010.12.00.6600.0139	Fleet Services-RTA Mtce Allocati		10,000	0	10,000	12,573	0		125.73
0010.12.00.6600.0145	Gasoline & Oil		26,000	0	26,000	28,841	0		110.93
0010.12.00.6600.1391	Fleet Services -Departmental Exp		57,441	0	57,441	31,853	0		55.45
0010.12.00.6600.1392	Fleet Svcs- Outside Vends		8,500	0	8,500	4,662	0		54.85
0010.12.00.6630.0142	Street Sign Maintenance		12,000	0	12,000	1,091	0		9.09
0010.12.00.6630.0148	Maintenance of Parks		0	0	0	(116)	0		0.00
0010.12.00.6700.0156	Equipment Rental/Lease		4,000	0	4,000	1,904	0		47.60
0010.12.00.6850.0180	Membership Dues and Fees		600	0	600	740	0		123.33
0010.12.00.6850.0182	Other Operating Expenses		4,500	0	4,500	2,773	0		61.62
0010.12.00.6850.0186	Training		4,700	0	4,700	1,077	0		22.91
0010.12.00.6850.0192	KGB Operations		0	0	0	426	0		100.00
0010.12.00.6860.0187	Professional Services		10,000	0	10,000	1,166	7,500		11.66
0010.12.00.6860.0189	Employee Medical		1,000	0	1,000	80	0		8.00
0010.12.00.6860.0195	Repair/Maint Svc Contract		30,300	0	30,300	15,153	4,250		50.01
0010.12.00.6860.1895	Employee wellness services		13,996	0	13,996	4,949	0		35.36
0010.12.00.6870.0204	Janitorial Services		2,709	0	2,709	1,620	810		59.80
0010.12.00.7030.1001	Agent Fees		1,155	0	1,155	0	0		0.00
0010.12.00.7950.0001	IT Internal Allocations		12,122	0	12,122	7,488	0		61.77
0010.13.00.4000.0101	Regular Pay		161,500	0	161,500	95,650	0		59.23
0010.13.00.4050.0114	FICA		12,600	0	12,600	7,066	0		56.08
0010.13.00.4060.0116	Retirement		30,100	0	30,100	17,405	0		57.82
0010.13.00.4080.0125	SCMIT Worker's Comp Ins.		1,305	0	1,305	758	0		58.08
0010.13.00.4100.0001	Health Claims Cost		11,985	0	11,985	22,638	0		188.89
0010.13.00.5000.0101	Supplies and Materials		0	0	0	665	0		100.00
0010.13.00.5000.0102	Equipment		0	0	0	1,192	0		100.00
0010.13.00.5000.0107	Technology Supplies		0	0	0	42	0		100.00
0010.13.00.6100.0111	Communications- Landline		500	0	500	0	0		0.00
0010.13.00.6100.1110	Communications- Wireless		700	0	700	970	0		138.57
0010.13.00.6400.0124	Travel Expense		3,388	0	3,388	0	0		0.00
0010.13.00.6500.0127	Electricity		1,007	0	1,007	607	0		60.28
0010.13.00.6500.0128	Water		265	0	265	214	0		80.75
0010.13.00.6500.0129	Wastewater		248	0	248	125	0		50.40
0010.13.00.6500.0130	Sanitation		301	0	301	170	0		56.48
0010.13.00.6500.0133	Stormwater		2,590	0	2,590	1,467	0		56.64
0010.13.00.6500.0134	Security Lights		557	0	557	315	0		56.55
0010.13.00.6500.1271	Electricity- Sales Tax		36	0	36	28	0		77.78
0010.13.00.6600.0145	Gasoline & Oil		1,000	0	1,000	140	0		14.00
0010.13.00.6600.1391	Fleet Services -Departmental Exp		0	0	0	190	0		100.00
0010.13.00.6850.0182	Other Operating Expenses		0	0	0	6,856	0		100.00
0010.13.00.6860.0184	Technology Services		325,038	0	325,038	165,606	81,923		50.95
0010.13.00.6860.0191	Contract Services/Studies		10,000	0	10,000	0	0		0.00
0010.13.00.6860.1895	Employee wellness services		998	0	998	408	0		40.88
0010.13.00.7950.0001	IT Internal Allocations		(606,118)	0	(606,118)	(370,987)	0		61.21
0010.13.00.9000.3950	Computer Software		0	0	0	37,995	0		100.00
0010.13.00.9000.4300	Other Equipment		42,000	0	42,000	14,675	132,928		34.94

BUDGET REPORT FOR CITY OF GEORGETOWN, SC
Calculations As of 01/31/2026

GL Number	Description	Original	25-26 Budget	25-26 Amended Amt Change	25-26 Budget	25-26 Activity	25-26 Encumbrance	% Budget	25-26 Used
Fund: 0010 General Fund									
Account Category: Appropriations									
0010.14.00.4000.0101	Regular Pay	181,000		0	181,000	105,006	0		58.01
0010.14.00.4010.0103	Overtime	1,000		0	1,000	34	0		3.40
0010.14.00.4050.0114	FICA	13,900		0	13,900	7,793	0		56.06
0010.14.00.4060.0116	Retirement	33,600		0	33,600	19,284	0		57.39
0010.14.00.4080.0125	SCMIT Worker's Comp Ins.	8,722		0	8,722	5,306	0		60.83
0010.14.00.4100.0001	Health Claims Cost	27,432		0	27,432	27,059	0		98.64
0010.14.00.4100.0002	Health Claim Costs-Retire	16,734		0	16,734	9,231	0		55.16
0010.14.00.5000.0101	Supplies and Materials	6,000		0	6,000	1,273	0		21.22
0010.14.00.5000.0102	Equipment	3,000		0	3,000	838	0		27.93
0010.14.00.5000.0105	Printing and Binding	600		0	600	24	0		4.00
0010.14.00.5000.0107	Technology Supplies	1,872		0	1,872	0	0		0.00
0010.14.00.5010.0101	Uniforms and Clothing	1,700		0	1,700	961	0		56.53
0010.14.00.5150.0121	Safety Supplies	600		0	600	267	0		44.50
0010.14.00.6100.0111	Communications- Landline	2,000		0	2,000	903	0		45.15
0010.14.00.6100.0112	Postage	200		0	200	0	0		0.00
0010.14.00.6100.1110	Communications- Wireless	600		0	600	236	0		39.33
0010.14.00.6200.0114	Advertising	100		0	100	0	0		0.00
0010.14.00.6400.0124	Travel Expense	600		0	600	0	0		0.00
0010.14.00.6500.0127	Electricity	10,583		0	10,583	8,332	0		78.73
0010.14.00.6500.0128	Water	1,311		0	1,311	607	0		46.30
0010.14.00.6500.0129	Wastewater	1,330		0	1,330	619	0		46.54
0010.14.00.6500.0130	Sanitation	457		0	457	258	0		56.46
0010.14.00.6500.0133	Stormwater	1,218		0	1,218	690	0		56.65
0010.14.00.6500.0134	Security Lights	527		0	527	298	0		56.55
0010.14.00.6500.1271	Electricity- Sales Tax	503		0	503	389	0		77.34
0010.14.00.6600.0133	Repairs & Maint. Services	2,000		0	2,000	1,038	0		51.90
0010.14.00.6600.0139	Fleet Services-RTA Mtce Allocati	3,500		0	3,500	47	0		1.34
0010.14.00.6600.0145	Gasoline & Oil	3,500		0	3,500	1,586	0		45.31
0010.14.00.6600.1391	Fleet Services -Departmental Exp	1,000		0	1,000	33	0		3.30
0010.14.00.6600.1392	Fleet Svcs- Outside Vends	1,000		0	1,000	0	0		0.00
0010.14.00.6620.0140	Building Repairs	1,500		0	1,500	160	0		10.67
0010.14.00.6700.0156	Equipment Rental/Lease	828		0	828	444	0		53.62
0010.14.00.6850.0182	Other Operating Expenses	500		0	500	96	0		19.20
0010.14.00.6850.0186	Training	1,000		0	1,000	0	0		0.00
0010.14.00.6860.0195	Repair/Maint Svc Contract	9,700		0	9,700	5,775	0		59.54
0010.14.00.6860.1895	Employee wellness services	1,995		0	1,995	757	0		37.94
0010.14.00.7030.1001	Agent Fees	700		0	700	0	0		0.00
0010.14.00.7350.0122	Services Billed	(353,715)		0	(353,715)	(209,121)	0		59.12
0010.14.00.7950.0001	IT Internal Allocations	12,122		0	12,122	7,488	0		61.77
0010.20.00.4010.0106	Contract Labor	4,000		0	4,000	0	0		0.00
0010.20.00.4100.0002	Health Claim Costs-Retire	31,200		0	31,200	(32,256)	0		(103.38)
0010.20.00.5100.0106	Cleaning & Sanitation Sup	3,000		0	3,000	961	0		32.03
0010.20.00.6000.0110	SCMIRF Property/Liab Ins	421,839		0	421,839	454,664	0		107.78
0010.20.00.6000.0112	Survivors Health Ins	16,000		0	16,000	0	0		0.00
0010.20.00.6000.1051	Employee wellness &Safety	13,300		0	13,300	4,177	0		31.41
0010.20.00.6000.1052	Unemployment Insurance	4,000		0	4,000	1,296	0		32.40
0010.20.00.6200.0114	Advertising	2,500		0	2,500	0	0		0.00
0010.20.00.6500.0127	Electricity	4,479		0	4,479	3,974	0		88.73
0010.20.00.6500.0128	Water	752		0	752	210	0		27.93

BUDGET REPORT FOR CITY OF GEORGETOWN, SC
Calculations As of 01/31/2026

GL Number	Description	Original	25-26 Budget	25-26 Amended Budget Amt Change	25-26 Amended Budget	25-26 Activity	25-26 Encumbrance	% Budget	25-26 Used
Fund: 0010 General Fund									
Account Category: Appropriations									
0010.20.00.6500.0129	Wastewater		1,266	0	1,266	1,231	0		97.24
0010.20.00.6500.0133	Stormwater		2,058	0	2,058	1,166	0		56.66
0010.20.00.6500.1271	Electricity- Sales Tax		86	0	86	111	0		129.07
0010.20.00.6600.0113	Opioid Recovery Program Expenses		110,000	0	110,000	9,471	76,128		8.61
0010.20.00.6600.0133	Repairs & Maint. Services		10,000	0	10,000	301	0		3.01
0010.20.00.6850.0180	Membership Dues and Fees		3,200	0	3,200	104	0		3.25
0010.20.00.6850.0182	Other Operating Expenses		41,088	0	41,088	79,828	0		194.29
0010.20.00.6850.0186	Training		0	0	0	8	0		100.00
0010.20.00.6850.1822	City Hall - Temporary Locations		133,700	0	133,700	69,216	0		51.77
0010.20.00.6860.0186	Legal Services		85,000	0	85,000	34,653	29,266		40.77
0010.20.00.6860.0187	Professional Services		14,500	0	14,500	3,274	0		22.58
0010.20.00.6860.0190	Consulting Services		5,000	0	5,000	0	0		0.00
0010.20.00.6860.0192	Elections		12,000	0	12,000	9,585	0		79.88
0010.20.00.6860.0194	Other Prof/Tech Services		0	0	0	2,700	0		100.00
0010.20.00.6860.0195	Repair/Maint Svc Contract		3,400	0	3,400	2,421	0		71.21
0010.20.00.6860.0196	Bank Charges/Fees		5,200	0	5,200	2,635	0		50.67
0010.20.00.6860.0199	Internal Engineering		26,669	0	26,669	28,381	0		106.42
0010.20.00.6860.1871	Audit Services		50,000	0	50,000	37,000	16,000		74.00
0010.20.00.6870.0204	Janitorial Services		11,983	0	11,983	5,200	2,600		43.39
0010.20.00.7950.0995	GF Cost Distribution		(406,488)	0	(406,488)	(237,118)	0		58.33
0010.21.00.6810.0100	Capital Lease Principal		23,398	0	23,398	23,398	0		100.00
0010.21.00.6810.0120	Capital Lease Interest		2,415	0	2,415	2,415	0		100.00
0010.21.00.6810.0130	GO Bond Principal		55,000	0	55,000	0	0		0.00
0010.21.00.6810.0140	GO Bond Interest		9,205	0	9,205	0	0		0.00
0010.21.00.7020.0105	Interest on Bonds		54,175	0	54,175	0	0		0.00
0010.21.00.7020.0110	Bond Principal		47,600	0	47,600	0	0		0.00
0010.22.00.7500.0127	Transfers to Waste Mgmt		92,135	0	92,135	0	0		0.00
Appropriations			15,118,937	0	15,118,937	8,320,679	529,833		55.03
Fund 0010 - General Fund:									
TOTAL ESTIMATED REVENUES			15,118,937	0	15,118,937	7,082,187	0		46.84
TOTAL APPROPRIATIONS			15,118,937	0	15,118,937	8,320,679	529,833		55.03
NET OF REVENUES & APPROPRIATIONS:			0	0	0	(1,238,492)	(529,833)		
			0.00%	0.00%	0.00%	-17.49%	0.00%		

BUDGET REPORT FOR CITY OF GEORGETOWN, SC
Calculations As of 01/31/2026

GL Number	Description	Original	25-26 Budget	25-26 Amended Budget Amt Change	25-26 Amended Budget	25-26 Activity	25-26 Encumbrance	% Budget	25-26 Used
Fund: 0011 Debt Service									
Account Category: Estimated Revenues									
0011.00.00.3110.0002	Property Taxes -Debt Mill		180,000	0	180,000	24,230	0		13.46
	Estimated Revenues		180,000	0	180,000	24,230	0		13.46
Account Category: Appropriations									
0011.21.00.6810.0130	GO Bond Principal		92,329	0	92,329	0	0		0.00
0011.21.00.6810.0140	GO Bond Interest		39,031	0	39,031	0	0		0.00
0011.21.00.7500.0137	Trns from/to Fund Balance		48,640	0	48,640	0	0		0.00
	Appropriations		180,000	0	180,000	0	0		0.00
Fund 0011 - Debt Service:									
	TOTAL ESTIMATED REVENUES		180,000	0	180,000	24,230	0		13.46
	TOTAL APPROPRIATIONS		180,000	0	180,000	0	0		0.00
	NET OF REVENUES & APPROPRIATIONS:		0	0	0	24,230	0		
			0.00%	0.00%	0.00%	100.00%	0.00%		

BUDGET REPORT FOR CITY OF GEORGETOWN, SC
Calculations As of 01/31/2026

GL Number	Description	Original	25-26 Budget	25-26 Amended Budget Amt Change	25-26 Amended Budget	25-26 Activity	25-26 Encumbrance	% Budget	25-26 Used
Fund: 0012 Capital Projects Reserve Fund									
Account Category: Estimated Revenues									
0012.00.00.3310.0010	Grant Revenue		189,650	0	189,650	0	0		0.00
0012.00.00.3630.0005	FOIA Fees		0	0	0	42	0		0.00
0012.00.00.3920.0015	Transfer from Capital Projects F		4,688,243	0	4,688,243	0	0		0.00
	Estimated Revenues		<u>4,877,893</u>	<u>0</u>	<u>4,877,893</u>	<u>42</u>	<u>0</u>		<u>0.00</u>
Account Category: Appropriations									
0012.00.00.6200.0114	Advertising		0	0	0	84	0		100.00
0012.26.00.9000.0903	Sidewalk Program		278,000	0	278,000	6,400	24,100		2.30
0012.26.00.9000.0904	Street Re-Surfacing Program		127,000	0	127,000	126,162	10,000		99.34
0012.26.00.9000.3000	Buildings & Improvements		2,995,693	0	2,995,693	680,789	1,084,056		22.73
0012.26.00.9000.3950	Computer Software		66,200	0	66,200	40,271	0		60.83
0012.26.00.9000.4100	Vehicles		594,050	0	594,050	349,409	236,635		58.82
0012.26.00.9000.4200	Heavy Equipment		0	0	0	48,222	41,641		100.00
0012.26.00.9000.4300	Other Equipment		816,950	0	816,950	320,001	182,789		39.17
	Appropriations		<u>4,877,893</u>	<u>0</u>	<u>4,877,893</u>	<u>1,571,338</u>	<u>1,579,221</u>		<u>32.21</u>
Fund 0012 - Capital Projects Reserve Fund:									
	TOTAL ESTIMATED REVENUES		4,877,893	0	4,877,893	42	0		0.00
	TOTAL APPROPRIATIONS		4,877,893	0	4,877,893	1,571,338	1,579,221		32.21
	NET OF REVENUES & APPROPRIATIONS:		<u>0</u>	<u>0</u>	<u>0</u>	<u>(1,571,296)</u>	<u>(1,579,221)</u>		
			0.00%	0.00%	0.00%	-3,741,180.95%	0.00%		

BUDGET REPORT FOR CITY OF GEORGETOWN, SC
 Calculations As of 01/31/2026

GL Number	Description	Original	25-26 Budget	25-26 Amended Amt Change	25-26 Budget	25-26 Activity	25-26 Encumbrance	% Budget	25-26 Used
Fund: 0013 TIF District									
Account Category: Estimated Revenues									
0013.00.00.3020.0006	TIF Proceeds		157,687	0	157,687	0	0		0.00
	Estimated Revenues		157,687	0	157,687	0	0		0.00
Account Category: Appropriations									
0013.00.00.7500.0137	Trns from/to Fund Balance		157,687	0	157,687	0	0		0.00
	Appropriations		157,687	0	157,687	0	0		0.00
Fund 0013 - TIF District:									
TOTAL ESTIMATED REVENUES			157,687	0	157,687	0	0		0.00
TOTAL APPROPRIATIONS			157,687	0	157,687	0	0		0.00
NET OF REVENUES & APPROPRIATIONS:			0	0	0	0	0		
			0.00%	0.00%	0.00%	0.00%	0.00%		

BUDGET REPORT FOR CITY OF GEORGETOWN, SC
 Calculations As of 01/31/2026

GL Number	Description	Original	25-26 Budget	25-26 Amended Budget Amt Change	25-26 Amended Budget	25-26 Activity	25-26 Encumbrance	% Budget	25-26 Used
Fund: 0015 Agency Fund									
Account Category: Estimated Revenues									
0015.00.00.3610.0001	Investment Earnings		0	0	0	847	0		0.00
	Estimated Revenues		0	0	0	847	0		0.00
Fund 0015 - Agency Fund:									
	TOTAL ESTIMATED REVENUES		0	0	0	847	0		0.00
	TOTAL APPROPRIATIONS		0	0	0	0	0		0.00
	NET OF REVENUES & APPROPRIATIONS:		0	0	0	847	0		
			0.00%	0.00%	0.00%	100.00%	0.00%		

BUDGET REPORT FOR CITY OF GEORGETOWN, SC
Calculations As of 01/31/2026

GL Number	Description	Original	25-26 Budget	25-26 Amended Budget Amt Change	25-26 Amended Budget	25-26 Activity	25-26 Encumbrance	% Budget	25-26 Used
Fund: 0018 State and Local Grants									
Account Category: Estimated Revenues									
0018.00.00.3310.0070	Hazard Mitigation Grant		402,522	0	402,522	0	0		0.00
0018.00.00.3320.0000	State Grants		12,000	0	12,000	17,098	0		142.48
	Estimated Revenues		<u>414,522</u>	<u>0</u>	<u>414,522</u>	<u>17,098</u>	<u>0</u>		<u>4.12</u>
Account Category: Appropriations									
0018.70.00.5000.0101	Supplies and Materials		8,000	0	8,000	16,969	0		212.11
0018.70.00.5000.0102	Equipment		4,000	0	4,000	0	0		0.00
0018.70.00.6850.0187	Special Projects		402,522	0	402,522	0	0		0.00
	Appropriations		<u>414,522</u>	<u>0</u>	<u>414,522</u>	<u>16,969</u>	<u>0</u>		<u>4.09</u>
Fund 0018 - State and Local Grants:									
	TOTAL ESTIMATED REVENUES		414,522	0	414,522	17,098	0		4.12
	TOTAL APPROPRIATIONS		414,522	0	414,522	16,969	0		4.09
	NET OF REVENUES & APPROPRIATIONS:		<u>0</u>	<u>0</u>	<u>0</u>	<u>129</u>	<u>0</u>		
			0.00%	0.00%	0.00%	0.75%	0.00%		

BUDGET REPORT FOR CITY OF GEORGETOWN, SC
Calculations As of 01/31/2026

GL Number	Description	Original	25-26 Budget	25-26 Amended Amt Change	25-26 Budget	25-26 Activity	25-26 Encumbrance	% Budget	25-26 Used
Fund: 0019 Res. Utilities Round Up Program									
Account Category: Estimated Revenues									
0019.00.00.3020.0007	Residential Utilities Round Up P		0	0	0	546	0		0.00
	Estimated Revenues		0	0	0	546	0		0.00
Fund 0019 - Res. Utilities Round Up Program:									
	TOTAL ESTIMATED REVENUES		0	0	0	546	0		0.00
	TOTAL APPROPRIATIONS		0	0	0	0	0		0.00
	NET OF REVENUES & APPROPRIATIONS:		0	0	0	546	0		
			0.00%	0.00%	0.00%	100.00%	0.00%		

BUDGET REPORT FOR CITY OF GEORGETOWN, SC
Calculations As of 01/31/2026

GL Number	Description	Original	25-26 Budget	25-26 Amended Amt Change	25-26 Budget	25-26 Activity	25-26 Encumbrance	% Budget	25-26 Used
Fund: 0020 State Accommodations Tax									
Account Category: Estimated Revenues									
0020.00.00.3180.0001	Accommodations Tax		170,000	0	170,000	103,721	0		61.01
0020.00.00.3610.0001	Investment Earnings		700	0	700	0	0		0.00
	Estimated Revenues		<u>170,700</u>	<u>0</u>	<u>170,700</u>	<u>103,721</u>	<u>0</u>		<u>60.76</u>
Account Category: Appropriations									
0020.33.00.6200.0114	Advertising		200	0	200	84	0		42.00
0020.33.00.6830.0173	Tourism Related		94,250	0	94,250	62,125	0		65.92
0020.33.00.6830.0174	Tourism Advertise/Promote		43,500	0	43,500	7,895	0		18.15
0020.33.00.6850.0187	Special Projects		500	0	500	0	0		0.00
0020.33.00.7500.0124	Transfers to General Fund		32,250	0	32,250	28,936	0		89.72
	Appropriations		<u>170,700</u>	<u>0</u>	<u>170,700</u>	<u>99,040</u>	<u>0</u>		<u>58.02</u>
Fund 0020 - State Accommodations Tax:									
	TOTAL ESTIMATED REVENUES		170,700	0	170,700	103,721	0		60.76
	TOTAL APPROPRIATIONS		170,700	0	170,700	99,040	0		58.02
	NET OF REVENUES & APPROPRIATIONS:		0	0	0	4,681	0		
			0.00%	0.00%	0.00%	4.51%	0.00%		

BUDGET REPORT FOR CITY OF GEORGETOWN, SC
Calculations As of 01/31/2026

GL Number	Description	Original	25-26 Budget	25-26 Amended Amt Change	25-26 Budget	25-26 Activity	25-26 Encumbrance	% Budget	25-26 Used
Fund: 0022 Local Hospitality/ATax									
Account Category: Estimated Revenues									
0022.00.00.3240.0001	Hospitality Fee	1,100,000		0	1,100,000	635,057	0		57.73
0022.00.00.3240.0002	Accommodation Fees	300,000		0	300,000	156,105	0		52.04
0022.00.00.3310.0000	Federal Grants	250,000		0	250,000	0	0		0.00
0022.00.00.3310.0069	Match Revenue	149,798		0	149,798	0	0		0.00
0022.00.00.3320.0015	DBA State Grant	109,154		0	109,154	0	0		0.00
0022.00.00.3610.0001	Investment Earnings	1,500		0	1,500	0	0		0.00
0022.00.00.3940.0002	Transfer from fund balance	1,447,614		0	1,447,614	0	0		0.00
	Estimated Revenues	3,358,066		0	3,358,066	791,162	0		23.56
Account Category: Appropriations									
0022.08.00.6500.0127	Electricity	6,000		0	6,000	6,473	0		107.88
0022.08.00.6850.0182	Other Operating Expenses	25,000		0	25,000	0	0		0.00
0022.23.00.4000.0101	Regular Pay	142,100		0	142,100	68,564	0		48.25
0022.23.00.4010.0103	Overtime	51,047		0	51,047	37,791	0		74.03
0022.23.00.4050.0114	FICA	14,800		0	14,800	7,751	0		52.37
0022.23.00.4060.0116	Retirement	41,000		0	41,000	17,838	0		43.51
0022.23.00.4100.0001	Health Claims Cost	4,042		0	4,042	8,951	0		221.45
0022.23.00.6810.0100	Capital Lease Principal	10,298		0	10,298	10,298	0		100.00
0022.23.00.6810.0120	Capital Lease Interest	1,063		0	1,063	1,063	0		100.00
0022.23.00.6850.0182	Other Operating Expenses	0		0	0	204	0		100.00
0022.23.00.7500.0124	Transfers to General Fund	125,000		0	125,000	72,917	0		58.33
0022.24.00.6200.1141	Advertising- Other	350		0	350	158	0		45.14
0022.24.00.6830.0174	Tourism Advertise/Promote	308,328		0	308,328	133,645	0		43.35
0022.24.00.6850.0182	Other Operating Expenses	293,500		0	293,500	102,501	74,006		34.92
0022.24.00.6850.0187	Special Projects	103,250		0	103,250	72,022	0		69.75
0022.24.00.6850.0192	KGB Operations	15,800		0	15,800	3,249	0		20.56
0022.24.00.6850.1871	way-finding project	50,000		0	50,000	10,887	0		21.77
0022.24.00.6860.0191	Contract Services/Studies	25,000		0	25,000	0	0		0.00
0022.24.00.6860.0195	Repair/Maint Svc Contract	90,000		0	90,000	58,477	28,353		64.97
0022.24.00.6860.0199	Internal Engineering	26,669		0	26,669	0	0		0.00
0022.24.00.6870.0204	Janitorial Services	90,000		0	90,000	47,108	37,400		52.34
0022.24.00.9000.0905	Park Improvements	1,042,000		0	1,042,000	6,434	64,498		0.62
0022.24.00.9000.1000	Infrastructure Improvemts	360,933		0	360,933	180,905	164,428		50.12
0022.24.00.9000.4300	Other Equipment	180,000		0	180,000	0	135,000		0.00
0022.24.00.9000.6000	Other Improvements	97,000		0	97,000	0	0		0.00
0022.29.00.6000.0110	SCMIRF Property/Liab Ins	39,628		0	39,628	40,743	0		102.81
0022.29.00.6500.0127	Electricity	3,240		0	3,240	1,255	0		38.73
0022.29.00.6500.0133	Stormwater	1,913		0	1,913	730	0		38.16
0022.29.00.6500.1271	Electricity- Sales Tax	105		0	105	34	0		32.38
0022.29.00.6870.0203	Contract Services	210,000		0	210,000	157,500	0		75.00
	Appropriations	3,358,066		0	3,358,066	1,047,498	503,685		31.19
Fund 0022 - Local Hospitality/ATax:									
	TOTAL ESTIMATED REVENUES	3,358,066		0	3,358,066	791,162	0		23.56
	TOTAL APPROPRIATIONS	3,358,066		0	3,358,066	1,047,498	503,685		31.19
	NET OF REVENUES & APPROPRIATIONS:	0		0	0	(256,336)	(503,685)		
		0.00%		0.00%	0.00%	-32.40%	0.00%		

BUDGET REPORT FOR CITY OF GEORGETOWN, SC
Calculations As of 01/31/2026

GL Number	Description	Original	25-26 Budget	25-26 Amended Amt Change	25-26 Budget	25-26 Activity	25-26 Encumbrance	% Budget	25-26 Used
Fund: 0030 Electric Utility Fund									
Account Category: Estimated Revenues									
0030.00.00.3010.0000	Sale of Utilities	15,441,667		0	15,441,667	8,874,760	0		57.47
0030.00.00.3010.0001	Revenue from Energy Efficiency P	30,000		0	30,000	69,810	0		232.70
0030.00.00.3010.0002	New Turn Ons	4,000		0	4,000	2,060	0		51.50
0030.00.00.3010.0004	Security Lights	295,000		0	295,000	99,210	0		33.63
0030.00.00.3010.0012	Restores	80,000		0	80,000	73,019	0		91.27
0030.00.00.3020.0001	Penalties	125,000		0	125,000	92,115	0		73.69
0030.00.00.3020.0002	Pole Rental	200,000		0	200,000	200,949	0		100.47
0030.00.00.3060.0001	Investment Earnings	200,000		0	200,000	118,642	0		59.32
0030.00.00.3690.0002	Miscellaneous Revenue	2,000		0	2,000	7,422	0		371.10
0030.00.00.3940.0002	Transfer from fund balance	630,454		0	630,454	0	0		0.00
	Estimated Revenues	17,008,121		0	17,008,121	9,537,987	0		56.08
Account Category: Appropriations									
0030.19.00.4000.0101	Regular Pay	1,287,000		0	1,287,000	662,799	0		51.50
0030.19.00.4010.0103	Overtime	36,000		0	36,000	13,972	0		38.81
0030.19.00.4010.0105	On-call pay	21,000		0	21,000	11,971	0		57.00
0030.19.00.4010.0106	Contract Labor	702,250		0	702,250	204,847	301,762		29.17
0030.19.00.4010.0107	Labor Billed	0		0	0	(5,115)	0		0.00
0030.19.00.4050.0114	FICA	101,500		0	101,500	50,286	0		49.54
0030.19.00.4060.0116	Retirement	245,000		0	245,000	124,882	0		50.97
0030.19.00.4080.0125	SCMIT Worker's Comp Ins.	86,788		0	86,788	54,688	0		63.01
0030.19.00.4100.0001	Health Claims Cost	116,704		0	116,704	209,852	0		179.82
0030.19.00.4100.0002	Health Claim Costs-Retire	41,463		0	41,463	37,009	0		89.26
0030.19.00.5000.0101	Supplies and Materials	17,900		0	17,900	12,548	0		70.10
0030.19.00.5000.0102	Equipment	8,500		0	8,500	4,096	0		48.19
0030.19.00.5000.0105	Printing and Binding	600		0	600	0	0		0.00
0030.19.00.5010.0101	Uniforms and Clothing	25,900		0	25,900	19,810	0		76.49
0030.19.00.5140.0114	Wire Expense	30,000		0	30,000	26,192	39,746		87.31
0030.19.00.5140.0116	Pole Line Hardware	27,000		0	27,000	17,917	71,498		66.36
0030.19.00.5140.0117	Poles & Crossarms	20,000		0	20,000	(26,687)	54,691		(133.44)
0030.19.00.5140.0118	Fuel for Peak Shaving Generation	100,000		0	100,000	43,508	0		43.51
0030.19.00.5150.0121	Safety Supplies	600		0	600	300	0		50.00
0030.19.00.5150.0123	Special Dept Supplies	20,000		0	20,000	9,346	0		46.73
0030.19.00.5210.0128	Meter Supplies	65,000		0	65,000	63,658	44,186		97.94
0030.19.00.5230.0133	Street Light Supplies	20,000		0	20,000	5,887	2,523		29.44
0030.19.00.5310.0143	Security Lights	40,000		0	40,000	3,835	16,733		9.59
0030.19.00.5310.0145	Transformer Supplies	95,000		0	95,000	112,259	272,683		118.17
0030.19.00.5400.0150	Power Purchases	9,339,050		0	9,339,050	5,422,219	0		58.06
0030.19.00.5400.0153	Energy Efficiency Program	50,000		0	50,000	6,249	0		12.50
0030.19.00.6000.0110	SCMIRF Property/Liab Ins	171,776		0	171,776	176,609	0		102.81
0030.19.00.6100.0111	Communications- Landline	5,500		0	5,500	2,439	0		44.35
0030.19.00.6100.0112	Postage	6,000		0	6,000	4,647	0		77.45
0030.19.00.6100.1110	Communications- wireless	14,200		0	14,200	7,098	0		49.99
0030.19.00.6200.0114	Advertising	2,000		0	2,000	168	0		8.40
0030.19.00.6400.0124	Travel Expense	14,400		0	14,400	2,549	0		17.70
0030.19.00.6500.0127	Electricity	20,680		0	20,680	17,240	0		83.37
0030.19.00.6500.0128	Water	1,808		0	1,808	903	0		49.94
0030.19.00.6500.0129	Wastewater	1,729		0	1,729	752	0		43.49
0030.19.00.6500.0130	Sanitation	2,084		0	2,084	1,181	0		56.67
0030.19.00.6500.0133	Stormwater	3,562		0	3,562	2,017	0		56.63

BUDGET REPORT FOR CITY OF GEORGETOWN, SC
Calculations As of 01/31/2026

GL Number	Description	Original	25-26 Budget	25-26 Amended Amt Change	25-26 Budget	25-26 Activity	25-26 Encumbrance	% Budget	25-26 Used
Fund: 0030 Electric Utility Fund									
Account Category: Appropriations									
0030.19.00.6500.0134	Security Lights		10,493	0	10,493	5,943	0		56.64
0030.19.00.6500.1271	Electricity- Sales Tax		572	0	572	489	0		85.49
0030.19.00.6600.0103	Emergency Preparedness		5,000	0	5,000	0	0		0.00
0030.19.00.6600.0133	Repairs & Maint. Services		3,000	0	3,000	0	0		0.00
0030.19.00.6600.0139	Fleet Services-RTA Mtce Allocati		15,000	0	15,000	8,144	0		54.29
0030.19.00.6600.0140	Hydraulic Repair		13,000	0	13,000	1,941	0		14.93
0030.19.00.6600.0145	Gasoline & Oil		35,000	0	35,000	16,329	0		46.65
0030.19.00.6600.1391	Fleet Services -Departmental Exp		33,214	0	33,214	18,415	0		55.44
0030.19.00.6600.1392	Fleet Svcs- Outside Vends		5,000	0	5,000	3,754	0		75.08
0030.19.00.6620.0141	Department Repairs		30,500	0	30,500	26,056	5,780		85.43
0030.19.00.6630.0145	Sub-Station Maintenance		3,000	0	3,000	61	0		2.03
0030.19.00.6630.0146	Transformers Repairs		15,000	0	15,000	0	0		0.00
0030.19.00.6640.0101	Community Education		1,000	0	1,000	0	0		0.00
0030.19.00.6700.0156	Equipment Rental/Lease		4,800	0	4,800	2,971	0		61.90
0030.19.00.6810.0100	Capital Lease Principal		53,695	0	53,695	53,695	0		100.00
0030.19.00.6810.0120	Capital Lease Interest		5,543	0	5,543	1,385	0		24.99
0030.19.00.6820.0170	Infrared Test		850	0	850	825	0		97.06
0030.19.00.6820.0171	Safety Testing/Compliance		5,000	0	5,000	3,649	0		72.98
0030.19.00.6820.0173	Tree Crew Maintenance		20,000	0	20,000	12,039	0		60.20
0030.19.00.6850.0180	Membership Dues and Fees		40,244	0	40,244	21,249	7,419		52.80
0030.19.00.6850.0182	Other Operating Expenses		50,000	0	50,000	24,355	0		48.71
0030.19.00.6850.0183	Depreciation		850,000	0	850,000	0	0		0.00
0030.19.00.6850.0186	Training		49,100	0	49,100	6,878	0		14.01
0030.19.00.6850.0190	Landfill Fees		30,000	0	30,000	4,343	0		14.48
0030.19.00.6860.0186	Legal Services		5,000	0	5,000	0	0		0.00
0030.19.00.6860.0187	Professional Services		296,000	0	296,000	217,267	89,368		73.40
0030.19.00.6860.0188	Architect/Engineer Servcs		170,000	0	170,000	99,510	19,294		58.54
0030.19.00.6860.0191	Contract Services/Studies		3,000	0	3,000	1,326	0		44.20
0030.19.00.6860.0195	Repair/Maint Svc Contract		31,300	0	31,300	16,463	0		52.60
0030.19.00.6860.0196	Bank Charges/Fees		25,000	0	25,000	12,120	0		48.48
0030.19.00.6860.0199	Internal Engineering		26,671	0	26,671	14,191	0		53.21
0030.19.00.6860.1895	Employee wellness services		13,996	0	13,996	4,949	0		35.36
0030.19.00.6870.0202	Utility Billing Services		58,000	0	58,000	16,489	0		28.43
0030.19.00.6870.0204	Janitorial Services		2,749	0	2,749	1,760	880		64.02
0030.19.00.6890.0800	Equipment Charges		0	0	0	(2,944)	0		0.00
0030.19.00.7020.0105	Interest on Bonds		105,950	0	105,950	(52,785)	0		(49.82)
0030.19.00.7020.0110	Bond Principal		710,000	0	710,000	0	0		0.00
0030.19.00.7030.1001	Agent Fees		3,760	0	3,760	2,500	0		66.49
0030.19.00.7500.0124	Transfers to General Fund		918,371	0	918,371	535,716	0		58.33
0030.19.00.7500.0141	Transfer to Water Utility		159,635	0	159,635	0	0		0.00
0030.19.00.7500.0142	Transfer to Wastewater		376,907	0	376,907	0	0		0.00
0030.19.00.7950.0001	IT Internal Allocations		151,531	0	151,531	93,594	0		61.77
0030.19.00.7950.0995	GF Cost Distribution		614,996	0	614,996	358,748	0		58.33
0030.19.00.7999.9999	Principal Reclassified		(710,000)	0	(710,000)	0	0		0.00
0030.19.00.9000.3000	Buildings & Improvements		1,052,418	0	1,052,418	277,619	597,024		26.38
0030.19.00.9000.3100	Electric Distribution		2,730,000	0	2,730,000	213,383	589,215		7.82
0030.19.00.9000.4100	Vehicles		245,000	0	245,000	241,628	500		98.62
0030.19.00.9000.4300	Other Equipment		238,500	0	238,500	176,064	26,374		73.82
0030.19.00.9000.6000	Other Improvements		34,500	0	34,500	19,550	0		56.67

BUDGET REPORT FOR CITY OF GEORGETOWN, SC
 Calculations As of 01/31/2026

GL Number	Description	Original	25-26 Budget	25-26 Amended Amt Change	25-26 Budget	25-26 Activity	25-26 Encumbrance	% Budget	25-26 Used
Fund: 0030 Electric Utility Fund									
Account Category: Appropriations									
0030.19.00.9999.9999	Assets Reclassified	(4,300,418)		0	(4,300,418)	0	0		0.00
0030.36.00.6620.0141	Department Repairs	25,000		0	25,000	1,927	0		7.71
0030.36.00.6850.0183	Depreciation	250		0	250	0	0		0.00
Appropriations		17,008,121		0	17,008,121	9,763,527	2,139,676		57.41
Fund 0030 - Electric Utility Fund:									
TOTAL ESTIMATED REVENUES		17,008,121		0	17,008,121	9,537,987	0		56.08
TOTAL APPROPRIATIONS		17,008,121		0	17,008,121	9,763,527	2,139,676		57.41
NET OF REVENUES & APPROPRIATIONS:		0		0	0	(225,540)	(2,139,676)		
		0.00%		0.00%	0.00%	-2.36%	0.00%		

BUDGET REPORT FOR CITY OF GEORGETOWN, SC
Calculations As of 01/31/2026

GL Number	Description	Original	25-26 Budget	25-26 Amended Amt Change	25-26 Budget	25-26 Activity	25-26 Encumbrance	% Budget	25-26 Used
Fund: 0031 Water Utility Fund									
Account Category: Estimated Revenues									
0031.00.00.3010.0000	Sale Of Utilities	4,339,130		0	4,339,130	2,010,164	0		46.33
0031.00.00.3010.0002	New Turn Ons	2,000		0	2,000	1,580	0		79.00
0031.00.00.3010.0006	Sale Of Raw Water	12,000		0	12,000	0	0		0.00
0031.00.00.3010.0009	New Service Taps	22,000		0	22,000	9,300	0		42.27
0031.00.00.3010.0013	Meter Installation	6,000		0	6,000	3,000	0		50.00
0031.00.00.3020.0001	Penalties	32,000		0	32,000	25,887	0		80.90
0031.00.00.3060.0001	Investment Earnings	30,000		0	30,000	23,387	0		77.96
0031.00.00.3070.0002	Sale Of Scrap	0		0	0	1,099	0		0.00
0031.00.00.3240.0020	Water Impact Fee	25,000		0	25,000	18,440	0		73.76
0031.00.00.3310.0000	Federal Grants	0		0	0	294,684	0		0.00
0031.00.00.3690.0002	Miscellaneous Revenue	8,000		0	8,000	4,168	0		52.10
0031.00.00.3690.0003	Insurance Proceeds	1,200		0	1,200	0	0		0.00
0031.00.00.3920.0016	Transfer from Electric Utility	159,635		0	159,635	0	0		0.00
	Estimated Revenues	4,636,965		0	4,636,965	2,391,709	0		51.58
Account Category: Appropriations									
0031.15.00.4000.0101	Regular Pay	284,500		0	284,500	157,715	0		55.44
0031.15.00.4010.0103	Overtime	17,000		0	17,000	15,813	0		93.02
0031.15.00.4010.0105	On-call pay	10,400		0	10,400	6,186	0		59.48
0031.15.00.4050.0114	FICA	24,500		0	24,500	13,224	0		53.98
0031.15.00.4060.0116	Retirement	58,000		0	58,000	32,683	0		56.35
0031.15.00.4080.0125	SCMIT Worker's Comp Ins.	17,626		0	17,626	10,485	0		59.49
0031.15.00.4100.0001	Health Claims Cost	25,837		0	25,837	50,230	0		194.41
0031.15.00.4100.0002	Health Claim Costs-Retire	2,279		0	2,279	0	0		0.00
0031.15.00.5000.0101	Supplies and Materials	7,600		0	7,600	1,664	0		21.89
0031.15.00.5000.0102	Equipment	9,500		0	9,500	0	0		0.00
0031.15.00.5010.0101	Uniforms and Clothing	4,400		0	4,400	1,659	0		37.70
0031.15.00.5130.0112	Asphalt/Concrete/Gravel	51,000		0	51,000	21,758	12,091		42.66
0031.15.00.5140.0110	Water Dist System Supply	105,000		0	105,000	92,771	0		88.35
0031.15.00.5150.0129	Permit Fees Due To Others	1,000		0	1,000	674	0		67.40
0031.15.00.5230.0136	Hydrant Replacement	10,000		0	10,000	0	0		0.00
0031.15.00.5320.0148	Small Hand Tools	500		0	500	178	0		35.60
0031.15.00.6000.0110	SCMIRF Property/Liab Ins	91,064		0	91,064	93,626	0		102.81
0031.15.00.6100.0112	Postage	4,000		0	4,000	10	0		0.25
0031.15.00.6100.1110	Communications- Wireless	2,040		0	2,040	444	0		21.76
0031.15.00.6200.0114	Advertising	600		0	600	84	0		14.00
0031.15.00.6400.0124	Travel Expense	100		0	100	0	0		0.00
0031.15.00.6500.0127	Electricity	10,318		0	10,318	5,306	0		51.42
0031.15.00.6500.0128	Water	59,342		0	59,342	25,373	0		42.76
0031.15.00.6500.0129	Wastewater	20,338		0	20,338	7,285	0		35.82
0031.15.00.6500.0130	Sanitation	692		0	692	392	0		56.65
0031.15.00.6500.0133	Stormwater	46,019		0	46,019	26,063	0		56.64
0031.15.00.6500.1271	Electricity- Sales Tax	331		0	331	323	0		97.58
0031.15.00.6600.0133	Repairs & Maint. Services	23,000		0	23,000	6,932	0		30.14
0031.15.00.6600.0139	Fleet Services-RTA Mtce Allocati	5,000		0	5,000	5,859	0		117.18
0031.15.00.6600.0145	Gasoline & Oil	10,000		0	10,000	4,719	0		47.19
0031.15.00.6600.1391	Fleet Services -Departmental Exp	7,853		0	7,853	6,890	0		87.74
0031.15.00.6600.1392	Fleet Svcs- Outside Vends	7,500		0	7,500	2,314	0		30.85
0031.15.00.6700.0156	Equipment Rental/Lease	500		0	500	0	0		0.00
0031.15.00.6850.0180	Membership Dues and Fees	200		0	200	136	0		68.00

BUDGET REPORT FOR CITY OF GEORGETOWN, SC
Calculations As of 01/31/2026

GL Number	Description	Original	25-26 Budget	25-26 Amended Amt Change	25-26 Budget	25-26 Activity	25-26 Encumbrance	% Budget	25-26 Used
Fund: 0031 Water Utility Fund									
Account Category: Appropriations									
0031.15.00.6850.0182	Other Operating Expenses		1,500	0	1,500	1,070	0		71.33
0031.15.00.6850.0183	Depreciation		512,000	0	512,000	0	0		0.00
0031.15.00.6850.0186	Training		6,100	0	6,100	2,734	0		44.82
0031.15.00.6860.0187	Professional Services		3,700	0	3,700	19,798	2,276		535.08
0031.15.00.6860.0189	Employee Medical		1,500	0	1,500	0	0		0.00
0031.15.00.6860.0191	Contract Services/Studies		52,000	0	52,000	1,326	0		2.55
0031.15.00.6860.0196	Bank Charges/Fees		10,000	0	10,000	4,743	0		47.43
0031.15.00.6860.0199	Internal Engineering		26,669	0	26,669	14,191	0		53.21
0031.15.00.6860.1895	Employee wellness services		5,004	0	5,004	1,806	0		36.09
0031.15.00.6870.0202	Utility Billing Services		10,000	0	10,000	2,494	0		24.94
0031.15.00.6870.0204	Janitorial Services		908	0	908	1,600	800		176.21
0031.15.00.7020.0106	Interest- Bonds		74,642	0	74,642	(10,675)	0		(14.30)
0031.15.00.7020.0110	Bond Principal		306,496	0	306,496	0	0		0.00
0031.15.00.7030.0109	Agents Fee		8,000	0	8,000	5,113	0		63.91
0031.15.00.7500.0124	Transfers to General Fund		189,009	0	189,009	110,255	0		58.33
0031.15.00.7950.0995	GF Cost Distribution		132,719	0	132,719	77,419	0		58.33
0031.15.00.7950.0999	Allocation G&A Services		86,240	0	86,240	43,200	0		50.09
0031.15.00.7999.9999	Principal Reclassified		(306,496)	0	(306,496)	0	0		0.00
0031.15.00.9000.3500	Water Distribution		4,834,185	0	4,834,185	74,212	1,142,652		1.54
0031.15.00.9000.4200	Heavy Equipment		65,000	0	65,000	55,566	0		85.49
0031.15.00.9000.4300	Other Equipment		12,000	0	12,000	104,290	0		869.08
0031.15.00.9999.9999	Assets Reclassified		(4,911,185)	0	(4,911,185)	0	0		0.00
0031.16.00.4000.0101	Regular Pay		333,750	0	333,750	182,268	0		54.61
0031.16.00.4010.0103	Overtime		8,500	0	8,500	7,243	0		85.21
0031.16.00.4010.0105	On-call pay		13,000	0	13,000	7,715	0		59.35
0031.16.00.4050.0114	FICA		27,500	0	27,500	14,333	0		52.12
0031.16.00.4060.0116	Retirement		66,000	0	66,000	36,045	0		54.61
0031.16.00.4080.0125	SCMIT Worker's Comp Ins.		15,589	0	15,589	9,443	0		60.57
0031.16.00.4100.0001	Health Claims Cost		50,915	0	50,915	52,295	0		102.71
0031.16.00.4100.0002	Health Claim Costs-Retire		12,215	0	12,215	0	0		0.00
0031.16.00.5000.0101	Supplies and Materials		2,500	0	2,500	922	0		36.88
0031.16.00.5000.0102	Equipment		28,327	0	28,327	6,122	0		21.61
0031.16.00.5010.0101	Uniforms and Clothing		4,000	0	4,000	1,128	0		28.20
0031.16.00.5120.0108	Chemicals		558,908	0	558,908	200,963	127,637		35.96
0031.16.00.5120.0109	Laboratory Supplies		28,000	0	28,000	16,464	0		58.80
0031.16.00.5150.0121	Safety Supplies		1,600	0	1,600	0	0		0.00
0031.16.00.5150.0129	Permit Fees Due To Others		23,000	0	23,000	19,640	0		85.39
0031.16.00.5320.0148	Small Hand Tools		300	0	300	34	0		11.33
0031.16.00.5400.0151	IP Raw Water Contract-Cty		47,394	0	47,394	37,196	1,436		78.48
0031.16.00.5400.0152	Raw Water Pump Maint.		65,000	0	65,000	10,341	0		15.91
0031.16.00.5400.0157	Treated Water Purchase		200	0	200	37	0		18.50
0031.16.00.5400.1510	IP Raw Water Contract-Stl		24,374	0	24,374	0	0		0.00
0031.16.00.6000.0110	SCMIRF Property/Liab Ins		274,486	0	274,486	282,209	0		102.81
0031.16.00.6100.0111	Communications- Landline		1,500	0	1,500	921	0		61.40
0031.16.00.6100.0112	Postage		800	0	800	111	0		13.88
0031.16.00.6100.1110	Communications- Wireless		660	0	660	520	0		78.79
0031.16.00.6200.0114	Advertising		1,000	0	1,000	0	0		0.00
0031.16.00.6400.0124	Travel Expense		100	0	100	0	0		0.00
0031.16.00.6500.0127	Electricity		91,065	0	91,065	6,754	0		7.42

BUDGET REPORT FOR CITY OF GEORGETOWN, SC
Calculations As of 01/31/2026

GL Number	Description	Original	25-26 Budget	25-26 Amended Amt Change	25-26 Budget	25-26 Activity	25-26 Encumbrance	% Budget	25-26 Used
Fund: 0031 Water Utility Fund									
Account Category: Appropriations									
0031.16.00.6500.0130	Sanitation		929	0	929	526	0		56.62
0031.16.00.6500.0133	Stormwater		5,270	0	5,270	2,985	0		56.64
0031.16.00.6500.0134	Security Lights		1,631	0	1,631	924	0		56.65
0031.16.00.6500.1271	Electricity- Sales Tax		73	0	73	6	0		8.22
0031.16.00.6600.0133	Repairs & Maint. Services		60,000	0	60,000	23,811	16,711		39.69
0031.16.00.6600.0139	Fleet Services-RTA Mtce Allocati		500	0	500	838	0		167.60
0031.16.00.6600.0145	Gasoline & Oil		1,750	0	1,750	2,146	0		122.63
0031.16.00.6600.1391	Fleet Services -Departmental Exp		2,441	0	2,441	1,896	0		77.67
0031.16.00.6600.1392	Fleet Svcs- Outside Vends		500	0	500	0	0		0.00
0031.16.00.6700.0156	Equipment Rental/Lease		500	0	500	0	0		0.00
0031.16.00.6850.0180	Membership Dues and Fees		1,100	0	1,100	90	0		8.18
0031.16.00.6850.0182	Other Operating Expenses		15,000	0	15,000	56	0		0.37
0031.16.00.6850.0183	Depreciation		293,000	0	293,000	0	0		0.00
0031.16.00.6850.0186	Training		2,420	0	2,420	333	0		13.76
0031.16.00.6860.0187	Professional Services		68,800	0	68,800	13,846	33,554		20.13
0031.16.00.6860.0189	Employee Medical		1,200	0	1,200	0	0		0.00
0031.16.00.6860.0195	Repair/Maint Svc Contract		2,000	0	2,000	1,356	0		67.80
0031.16.00.6860.0199	Internal Engineering		26,669	0	26,669	14,191	0		53.21
0031.16.00.6860.1895	Employee wellness services		6,001	0	6,001	2,155	0		35.91
0031.16.00.6870.0204	Janitorial Services		2,709	0	2,709	1,600	800		59.06
0031.16.00.7020.0105	Interest on Bonds		51,987	0	51,987	(4,332)	0		(8.33)
0031.16.00.7020.0110	Bond Principal		36,977	0	36,977	0	0		0.00
0031.16.00.7030.1001	Agent Fees		0	0	0	1,670	0		100.00
0031.16.00.7500.0124	Transfers to General Fund		168,422	0	168,422	98,246	0		58.33
0031.16.00.7950.0995	GF Cost Distribution		118,262	0	118,262	68,986	0		58.33
0031.16.00.7950.0999	Allocation G&A Services		86,240	0	86,240	43,200	0		50.09
0031.16.00.7999.9999	Principal Reclassified		(36,977)	0	(36,977)	0	0		0.00
0031.16.00.9000.3000	Buildings & Improvements		40,000	0	40,000	13,810	0		34.53
0031.16.00.9000.3300	Water Filtration Plant		925,000	0	925,000	1,029,772	684,139		111.33
0031.16.00.9000.4100	Vehicles		45,000	0	45,000	34,005	0		75.57
0031.16.00.9999.9999	Assets Reclassified		(1,010,000)	0	(1,010,000)	0	0		0.00
0031.41.00.4000.0101	Regular Pay		154,500	0	154,500	49,342	0		31.94
0031.41.00.4010.0103	Overtime		0	0	0	71	0		100.00
0031.41.00.4050.0114	FICA		11,900	0	11,900	3,595	0		30.21
0031.41.00.4060.0116	Retirement		29,000	0	29,000	9,088	0		31.34
0031.41.00.4080.0125	SCMIT Worker's Comp Ins.		5,754	0	5,754	2,874	0		49.95
0031.41.00.4100.0001	Health Claims Cost		20,370	0	20,370	35,141	0		172.51
0031.41.00.5000.0101	Supplies and Materials		5,400	0	5,400	2,453	0		45.43
0031.41.00.5000.0102	Equipment		2,000	0	2,000	437	0		21.85
0031.41.00.5000.0103	Furniture		1,000	0	1,000	0	0		0.00
0031.41.00.5010.0101	Uniforms and Clothing		500	0	500	0	0		0.00
0031.41.00.6000.0110	SCMIRF Property/Liab Ins		485	0	485	499	0		102.89
0031.41.00.6100.0111	Communications- Landline		4,800	0	4,800	525	0		10.94
0031.41.00.6100.0112	Postage		1,500	0	1,500	648	0		43.20
0031.41.00.6100.1110	Communications- Wireless		660	0	660	234	0		35.45
0031.41.00.6400.0124	Travel Expense		100	0	100	0	0		0.00
0031.41.00.6500.0127	Electricity		3,305	0	3,305	2,119	0		64.11
0031.41.00.6500.0128	Water		440	0	440	228	0		51.82
0031.41.00.6500.0129	Wastewater		492	0	492	254	0		51.63

BUDGET REPORT FOR CITY OF GEORGETOWN, SC
Calculations As of 01/31/2026

GL Number	Description	Original	25-26 Budget	25-26 Amended Amt Change	25-26 Budget	25-26 Activity	25-26 Encumbrance	% Budget	25-26 Used
Fund: 0031 Water Utility Fund									
Account Category: Appropriations									
0031.41.00.6500.0130	Sanitation		487	0	487	275	0		56.47
0031.41.00.6500.0133	Stormwater		3,112	0	3,112	1,762	0		56.62
0031.41.00.6500.0134	Security Lights		655	0	655	371	0		56.64
0031.41.00.6500.1271	Electricity- Sales Tax		94	0	94	79	0		84.04
0031.41.00.6600.0133	Repairs & Maint. Services		8,000	0	8,000	4,894	0		61.18
0031.41.00.6600.0139	Fleet Services-RTA Mtce Allocati		500	0	500	1,209	0		241.80
0031.41.00.6600.0145	Gasoline & Oil		2,500	0	2,500	1,232	0		49.28
0031.41.00.6600.1391	Fleet Services -Departmental Exp		3,006	0	3,006	1,817	0		60.45
0031.41.00.6600.1392	Fleet Svcs- Outside Vends		500	0	500	0	0		0.00
0031.41.00.6700.0156	Equipment Rental/Lease		3,800	0	3,800	846	0		22.26
0031.41.00.6850.0180	Membership Dues and Fees		1,600	0	1,600	750	0		46.88
0031.41.00.6850.0182	Other Operating Expenses		1,500	0	1,500	293	0		19.53
0031.41.00.6850.0183	Depreciation		2,700	0	2,700	0	0		0.00
0031.41.00.6850.0186	Training		800	0	800	0	0		0.00
0031.41.00.6860.0187	Professional Services		1,640	0	1,640	0	0		0.00
0031.41.00.6860.0189	Employee Medical		500	0	500	0	0		0.00
0031.41.00.6860.0195	Repair/Maint Svc Contract		2,200	0	2,200	1,025	0		46.59
0031.41.00.6860.1895	Employee wellness services		1,995	0	1,995	757	0		37.94
0031.41.00.6870.0204	Janitorial Services		2,724	0	2,724	1,600	800		58.74
0031.41.00.7950.0001	IT Internal Allocations		151,531	0	151,531	93,594	0		61.77
0031.41.00.7950.0999	Allocation G&A Services		(431,202)	0	(431,202)	(215,998)	0		50.09
0031.41.00.9000.3000	Buildings & Improvements		115,000	0	115,000	0	0		0.00
0031.41.00.9000.4100	Vehicles		45,000	0	45,000	0	42,239		0.00
0031.41.00.9999.9999	Assets Reclassified		(160,000)	0	(160,000)	0	0		0.00
0031.42.00.4000.0101	Regular Pay		162,000	0	162,000	96,675	0		59.68
0031.42.00.4050.0114	FICA		12,500	0	12,500	6,939	0		55.51
0031.42.00.4060.0116	Retirement		31,000	0	31,000	17,258	0		55.67
0031.42.00.4080.0125	SCMIT Worker's Comp Ins.		150	0	150	0	0		0.00
0031.42.00.4100.0001	Health Claims Cost		22,484	0	22,484	11,471	0		51.02
0031.42.00.5000.0101	Supplies and Materials		300	0	300	122	0		40.67
0031.42.00.5000.0102	Equipment		3,000	0	3,000	0	0		0.00
0031.42.00.5000.0105	Printing and Binding		300	0	300	0	0		0.00
0031.42.00.5010.0101	Uniforms and Clothing		600	0	600	0	0		0.00
0031.42.00.5150.0121	Safety Supplies		300	0	300	91	0		30.33
0031.42.00.5150.0124	Department Supplies		300	0	300	0	0		0.00
0031.42.00.6000.0110	SCMIRF Property/Liab Ins		809	0	809	831	0		102.72
0031.42.00.6100.0112	Postage		50	0	50	0	0		0.00
0031.42.00.6100.1110	Communications- Wireless		1,200	0	1,200	412	0		34.33
0031.42.00.6400.0124	Travel Expense		600	0	600	114	0		19.00
0031.42.00.6600.1391	Fleet Services -Departmental Exp		3,006	0	3,006	0	0		0.00
0031.42.00.6850.0180	Membership Dues and Fees		850	0	850	450	0		52.94
0031.42.00.6850.0182	Other Operating Expenses		5,250	0	5,250	51	0		0.97
0031.42.00.6850.0183	Depreciation		5,500	0	5,500	0	0		0.00
0031.42.00.6850.0184	Continuing Education		3,000	0	3,000	1,672	0		55.73
0031.42.00.6850.0186	Training		1,500	0	1,500	1,200	0		80.00
0031.42.00.6860.0187	Professional Services		10,000	0	10,000	3,863	0		38.63
0031.42.00.6860.1895	Employee wellness services		1,995	0	1,995	757	0		37.94
0031.42.00.7350.0122	Services Billed		(266,694)	0	(266,694)	(141,906)	0		53.21
Appropriations			4,636,965	0	4,636,965	3,346,772	2,065,135		72.18

BUDGET REPORT FOR CITY OF GEORGETOWN, SC
 Calculations As of 01/31/2026

GL Number	Description	Original	25-26 Budget	Amended Amt	25-26 Budget	Amended Budget	25-26 Activity	25-26 Encumbrance	% Budget	25-26 Used
Fund: 0031 Water Utility Fund										
Fund 0031 - Water Utility Fund:										
	TOTAL ESTIMATED REVENUES		4,636,965		0	4,636,965	2,391,709			51.58
	TOTAL APPROPRIATIONS		4,636,965		0	4,636,965	3,346,772	2,065,135		72.18
	NET OF REVENUES & APPROPRIATIONS:		0		0	0	(955,063)	(2,065,135)		
			0.00%		0.00%	0.00%	-39.93%	0.00%		

BUDGET REPORT FOR CITY OF GEORGETOWN, SC
Calculations As of 01/31/2026

GL Number	Description	Original	25-26 Budget	25-26 Amended Amt Change	25-26 Budget	25-26 Activity	25-26 Encumbrance	% Budget	25-26 Used
Fund: 0032 Wastewater Fund									
Account Category: Estimated Revenues									
0032.00.00.3010.0000	Sale of Utilities	3,888,621		0	3,888,621	1,832,076	0		47.11
0032.00.00.3010.0002	New Turn Ons	2,500		0	2,500	1,490	0		59.60
0032.00.00.3010.0009	New Service Taps	15,000		0	15,000	5,400	0		36.00
0032.00.00.3010.0014	Fixed Charges - Andrews	94,578		0	94,578	59,709	0		63.13
0032.00.00.3010.0015	Fixed Charges - GCWSD	179,831		0	179,831	113,531	0		63.13
0032.00.00.3010.0016	Fixed Charges - COG	402,541		0	402,541	0	0		0.00
0032.00.00.3010.0017	Volume Charges - Andrews	250,000		0	250,000	130,535	0		52.21
0032.00.00.3010.0018	Volume Charges - GCWSD	480,000		0	480,000	232,851	0		48.51
0032.00.00.3010.0019	Volume Charges - COG	750,000		0	750,000	0	0		0.00
0032.00.00.3010.0026	Fixed- Elim Georgetown	(402,541)		0	(402,541)	0	0		0.00
0032.00.00.3010.0029	Volume-Elim-Georgetown	(750,000)		0	(750,000)	0	0		0.00
0032.00.00.3020.0001	Penalties	35,000		0	35,000	26,127	0		74.65
0032.00.00.3030.0006	Septic Tank Dumping	30,000		0	30,000	20,692	0		68.97
0032.00.00.3060.0001	Investment Earnings	60,000		0	60,000	20,269	0		33.78
0032.00.00.3240.0017	Wastewater Impact Fee	19,800		0	19,800	20,760	0		104.85
0032.00.00.3310.0000	Federal Grants	0		0	0	2,894,042	0		0.00
0032.00.00.3690.0002	Miscellaneous Revenue	150		0	150	44	0		29.33
0032.00.00.3920.0001	From Electric Fund	376,907		0	376,907	0	0		0.00
	Estimated Revenues	5,432,387		0	5,432,387	5,357,526	0		98.62
Account Category: Appropriations									
0032.18.00.4000.0101	Regular Pay	314,500		0	314,500	150,804	0		47.95
0032.18.00.4010.0103	Overtime	5,000		0	5,000	3,679	0		73.58
0032.18.00.4010.0105	On-call pay	10,400		0	10,400	4,521	0		43.47
0032.18.00.4050.0114	FICA	25,750		0	25,750	11,524	0		44.75
0032.18.00.4060.0116	Retirement	62,000		0	62,000	29,114	0		46.96
0032.18.00.4080.0125	SCMIT Worker's Comp Ins.	28,647		0	28,647	19,655	0		68.61
0032.18.00.4100.0001	Health Claims Cost	60,379		0	60,379	80,536	0		133.38
0032.18.00.4100.0002	Health Claim Costs-Retire	18,994		0	18,994	0	0		0.00
0032.18.00.5000.0101	Supplies and Materials	5,600		0	5,600	4,205	0		75.09
0032.18.00.5000.0102	Equipment	20,000		0	20,000	8,368	0		41.84
0032.18.00.5000.0107	Technology Supplies	4,681		0	4,681	0	0		0.00
0032.18.00.5010.0101	Uniforms and Clothing	5,700		0	5,700	3,056	0		53.61
0032.18.00.5120.0108	Chemicals	6,500		0	6,500	0	0		0.00
0032.18.00.5130.0112	Asphalt/Concrete/Gravel	40,000		0	40,000	4,768	0		11.92
0032.18.00.5140.0111	Ww Collection Syst Supply	10,000		0	10,000	11,195	0		111.95
0032.18.00.5150.0121	Safety Supplies	900		0	900	300	0		33.33
0032.18.00.5320.0148	Small Hand Tools	400		0	400	183	0		45.75
0032.18.00.5320.1481	Small Hand Tools - Maintenance	600		0	600	0	0		0.00
0032.18.00.6000.0110	SCMIRF Property/Liab Ins	77,477		0	77,477	79,657	0		102.81
0032.18.00.6100.0112	Postage	1,000		0	1,000	573	0		57.30
0032.18.00.6100.1110	Communications- wireless	3,100		0	3,100	1,077	0		34.74
0032.18.00.6200.0114	Advertising	500		0	500	168	0		33.60
0032.18.00.6400.0124	Travel Expense	200		0	200	0	0		0.00
0032.18.00.6500.0127	Electricity	104,130		0	104,130	63,070	0		60.57
0032.18.00.6500.0133	Stormwater	19,186		0	19,186	10,866	0		56.64
0032.18.00.6500.0134	Security Lights	1,496		0	1,496	847	0		56.62
0032.18.00.6500.1271	Electricity- Sales Tax	2,701		0	2,701	1,808	0		66.94
0032.18.00.6600.0133	Repairs & Maint. Services	120,000		0	120,000	63,572	0		52.98
0032.18.00.6600.0139	Fleet Services-RTA Mtce Allocati	12,000		0	12,000	10,840	0		90.33

BUDGET REPORT FOR CITY OF GEORGETOWN, SC
Calculations As of 01/31/2026

GL Number	Description	Original	25-26 Budget	25-26 Amended Amt Change	25-26 Budget	25-26 Activity	25-26 Encumbrance	% Budget	25-26 Used
Fund: 0032 Wastewater Fund									
Account Category: Appropriations									
0032.18.00.6600.0145	Gasoline & Oil		23,625	0	23,625	12,479	0		52.82
0032.18.00.6600.1391	Fleet Services -Departmental Exp		34,204	0	34,204	19,557	0		57.18
0032.18.00.6600.1392	Fleet Svcs- Outside Vends		1,000	0	1,000	3,738	0		373.80
0032.18.00.6700.0156	Equipment Rental/Lease		6,000	0	6,000	0	0		0.00
0032.18.00.6810.0100	Capital Lease Principal		60,000	0	60,000	60,000	0		100.00
0032.18.00.6810.0120	Capital Lease Interest		4,920	0	4,920	1,640	0		33.33
0032.18.00.6850.0180	Membership Dues and Fees		600	0	600	45	0		7.50
0032.18.00.6850.0182	Other Operating Expenses		5,000	0	5,000	1,465	0		29.30
0032.18.00.6850.0183	Depreciation		490,000	0	490,000	0	0		0.00
0032.18.00.6850.0186	Training		2,250	0	2,250	0	0		0.00
0032.18.00.6860.0187	Professional Services		6,400	0	6,400	2,165	1,612		33.83
0032.18.00.6860.0189	Employee Medical		1,000	0	1,000	177	0		17.70
0032.18.00.6860.0191	Contract Services/Studies		2,220	0	2,220	1,330	0		59.91
0032.18.00.6860.0195	Repair/Maint Svc Contract		20,000	0	20,000	0	0		0.00
0032.18.00.6860.0196	Bank Charges/Fees		8,000	0	8,000	3,952	0		49.40
0032.18.00.6860.0199	Internal Engineering		26,669	0	26,669	14,191	0		53.21
0032.18.00.6860.1895	Employee wellness services		6,998	0	6,998	2,504	0		35.78
0032.18.00.6870.0202	Utility Billing Services		10,000	0	10,000	2,258	0		22.58
0032.18.00.6870.0204	Janitorial Services		3,617	0	3,617	0	0		0.00
0032.18.00.7020.0106	Interest- Bonds		118,306	0	118,306	(13,705)	0		(11.58)
0032.18.00.7020.0110	Bond Principal		177,627	0	177,627	0	0		0.00
0032.18.00.7030.1001	Agent Fees		4,301	0	4,301	3,024	0		70.31
0032.18.00.7500.0124	Transfers to General Fund		237,843	0	237,843	138,742	0		58.33
0032.18.00.7950.0995	GF Cost Distribution		123,180	0	123,180	71,855	0		58.33
0032.18.00.7950.0999	Allocation G&A Services		107,801	0	107,801	54,000	0		50.09
0032.18.00.7999.9999	Principal Reclassified		(177,627)	0	(177,627)	0	0		0.00
0032.18.00.9000.0911	Sewer Improvement Projects		500,000	0	500,000	3,423,843	7,207,938		684.77
0032.18.00.9000.3700	Wastewater Collection Sys		650,000	0	650,000	23,809	186,227		3.66
0032.18.00.9000.4100	Vehicles		58,000	0	58,000	57,449	0		99.05
0032.18.00.9000.4200	Heavy Equipment		150,000	0	150,000	0	127,923		0.00
0032.18.00.9000.4300	Other Equipment		20,000	0	20,000	6,004	61,526		30.02
0032.18.00.9999.9999	Assets Reclassified		(1,378,000)	0	(1,378,000)	0	0		0.00
0032.34.00.4000.0101	Regular Pay		372,000	0	372,000	204,221	0		54.90
0032.34.00.4010.0103	Overtime		15,000	0	15,000	10,113	0		67.42
0032.34.00.4010.0105	On-call pay		14,000	0	14,000	7,714	0		55.10
0032.34.00.4050.0114	FICA		31,000	0	31,000	16,027	0		51.70
0032.34.00.4060.0116	Retirement		74,500	0	74,500	40,753	0		54.70
0032.34.00.4080.0125	SCMIT worker's Comp Ins.		6,337	0	6,337	3,790	0		59.81
0032.34.00.4100.0001	Health Claims Cost		65,108	0	65,108	68,190	0		104.73
0032.34.00.5000.0101	Supplies and Materials		2,800	0	2,800	2,143	0		76.54
0032.34.00.5000.0102	Equipment		10,272	0	10,272	9,153	0		89.11
0032.34.00.5010.0101	Uniforms and Clothing		4,000	0	4,000	2,499	0		62.48
0032.34.00.5120.0108	Chemicals		220,000	0	220,000	51,365	91,454		23.35
0032.34.00.5120.0109	Laboratory Supplies		24,000	0	24,000	13,546	0		56.44
0032.34.00.5150.0121	Safety Supplies		900	0	900	0	0		0.00
0032.34.00.5150.0129	Permit Fees Due To Others		9,700	0	9,700	8,099	0		83.49
0032.34.00.5320.0148	Small Hand Tools		500	0	500	308	0		61.60
0032.34.00.6000.0110	SCMIRF Property/Liab Ins		428,309	0	428,309	440,359	0		102.81
0032.34.00.6100.0111	Communications- Landline		2,400	0	2,400	1,115	0		46.46

BUDGET REPORT FOR CITY OF GEORGETOWN, SC
Calculations As of 01/31/2026

GL Number	Description	Original	25-26 Budget	25-26 Amended Amt Change	25-26 Budget	25-26 Activity	25-26 Encumbrance	% Budget	25-26 Used
Fund: 0032 Wastewater Fund									
Account Category: Appropriations									
0032.34.00.6100.0112	Postage		1,200	0	1,200	0	0		0.00
0032.34.00.6100.1110	Communications- Wireless		660	0	660	869	0		131.67
0032.34.00.6200.0114	Advertising		500	0	500	84	0		16.80
0032.34.00.6400.0124	Travel Expense		100	0	100	0	0		0.00
0032.34.00.6500.0127	Electricity		271,109	0	271,109	286,714	0		105.76
0032.34.00.6500.0128	Water		2,569	0	2,569	3,051	0		118.76
0032.34.00.6500.0130	Sanitation		3,239	0	3,239	1,835	0		56.65
0032.34.00.6500.0133	Stormwater		81,038	0	81,038	45,896	0		56.64
0032.34.00.6500.0134	Security Lights		4,288	0	4,288	2,429	0		56.65
0032.34.00.6500.1271	Electricity- Sales Tax		10,538	0	10,538	9,361	0		88.83
0032.34.00.6600.0133	Repairs & Maint. Services		175,000	0	175,000	68,564	61,885		39.18
0032.34.00.6600.0139	Fleet Services-RTA Mtce Allocati		3,000	0	3,000	1,006	0		33.53
0032.34.00.6600.0145	Gasoline & Oil		3,707	0	3,707	898	0		24.22
0032.34.00.6600.1391	Fleet Services -Departmental Exp		1,592	0	1,592	1,388	0		87.19
0032.34.00.6600.1392	Fleet Svcs- Outside Vends		150	0	150	0	0		0.00
0032.34.00.6700.0156	Equipment Rental/Lease		1,200	0	1,200	0	0		0.00
0032.34.00.6850.0180	Membership Dues and Fees		425	0	425	180	0		42.35
0032.34.00.6850.0182	Other Operating Expenses		1,000	0	1,000	111	0		11.10
0032.34.00.6850.0183	Depreciation		8,200	0	8,200	0	0		0.00
0032.34.00.6850.0186	Training		2,150	0	2,150	70	0		3.26
0032.34.00.6850.0190	Landfill Fees		75,000	0	75,000	24,206	12,607		32.27
0032.34.00.6860.0187	Professional Services		68,975	0	68,975	7,044	0		10.21
0032.34.00.6860.0189	Employee Medical		1,100	0	1,100	0	0		0.00
0032.34.00.6860.0195	Repair/Maint Svc Contract		2,220	0	2,220	1,802	0		81.17
0032.34.00.6860.0199	Internal Engineering		53,339	0	53,339	28,381	0		53.21
0032.34.00.6860.1895	Employee wellness services		5,004	0	5,004	1,806	0		36.09
0032.34.00.6870.0204	Janitorial Services		0	0	0	1,600	800		100.00
0032.34.00.7020.0106	Interest- Bonds		104,114	0	104,114	(8,676)	0		(8.33)
0032.34.00.7020.0110	Bond Principal		375,505	0	375,505	0	0		0.00
0032.34.00.7030.0109	Agents Fee		5,800	0	5,800	3,113	0		53.67
0032.34.00.7500.0124	Transfers to General Fund		157,959	0	157,959	92,143	0		58.33
0032.34.00.7950.0995	GF Cost Distribution		81,809	0	81,809	47,722	0		58.33
0032.34.00.7950.0999	Allocation G&A Services		107,801	0	107,801	54,000	0		50.09
0032.34.00.7999.9999	Principal Reclassified		(375,505)	0	(375,505)	0	0		0.00
0032.34.00.9000.3000	Buildings & Improvements		125,000	0	125,000	0	107,489		0.00
0032.34.00.9000.3900	Wastewater Treatment Plnt		100,000	0	100,000	40,020	482,156		40.02
0032.34.00.9000.4100	Vehicles		360,000	0	360,000	0	0		0.00
0032.34.00.9000.4200	Heavy Equipment		0	0	0	49,919	282,698		100.00
0032.34.00.9000.4300	Other Equipment		312,000	0	312,000	87,936	105,621		28.18
0032.34.00.9999.9999	Assets Reclassified		(897,000)	0	(897,000)	0	0		0.00
0032.34.17.6850.0183	Depreciation		651,000	0	651,000	0	0		0.00
Appropriations			5,432,387	0	5,432,387	6,187,775	8,729,936		113.91
Fund 0032 - Wastewater Fund:									
TOTAL ESTIMATED REVENUES			5,432,387	0	5,432,387	5,357,526	0		98.62
TOTAL APPROPRIATIONS			5,432,387	0	5,432,387	6,187,775	8,729,936		113.91
NET OF REVENUES & APPROPRIATIONS:			0	0	0	(830,249)	(8,729,936)		
			0.00%	0.00%	0.00%	-15.50%	0.00%		

BUDGET REPORT FOR CITY OF GEORGETOWN, SC
Calculations As of 01/31/2026

GL Number	Description	Original	25-26 Budget	25-26 Amended Amt Change	25-26 Budget	25-26 Activity	25-26 Encumbrance	% Budget	25-26 Used
Fund: 0033 Stormwater Utility Fund									
Account Category: Estimated Revenues									
0033.00.00.3010.0000	Sale of Utilities	1,559,199		0	1,559,199	1,006,588	0		64.56
0033.00.00.3020.0001	Penalties	9,753		0	9,753	7,437	0		76.25
0033.00.00.3690.0002	Miscellaneous Revenue	1,000		0	1,000	0	0		0.00
	Estimated Revenues	1,569,952		0	1,569,952	1,014,025	0		64.59
Account Category: Appropriations									
0033.40.00.4000.0101	Regular Pay	253,000		0	253,000	130,380	0		51.53
0033.40.00.4010.0103	Overtime	3,000		0	3,000	1,926	0		64.20
0033.40.00.4010.0105	On-call pay	4,500		0	4,500	3,793	0		84.29
0033.40.00.4050.0114	FICA	21,000		0	21,000	9,826	0		46.79
0033.40.00.4060.0116	Retirement	49,000		0	49,000	24,814	0		50.64
0033.40.00.4080.0125	SCMIT Worker's Comp Ins.	19,738		0	19,738	11,970	0		60.64
0033.40.00.4100.0001	Health Claims Cost	59,903		0	59,903	51,346	0		85.72
0033.40.00.4100.0002	Health Claim Costs-Retire	14,175		0	14,175	6,930	0		48.89
0033.40.00.5000.0101	Supplies and Materials	2,300		0	2,300	2,257	0		98.13
0033.40.00.5000.0102	Equipment	5,000		0	5,000	0	0		0.00
0033.40.00.5010.0101	Uniforms and Clothing	5,000		0	5,000	2,463	0		49.26
0033.40.00.5130.0112	Asphalt/Concrete/Gravel	7,750		0	7,750	1,139	0		14.70
0033.40.00.5140.0112	SW Collection Syst Supply	10,000		0	10,000	0	0		0.00
0033.40.00.5150.0121	Safety Supplies	1,200		0	1,200	927	0		77.25
0033.40.00.5320.0148	Small Hand Tools	300		0	300	0	0		0.00
0033.40.00.6000.0110	SCMIRF Property/Liab Ins	103,195		0	103,195	106,099	0		102.81
0033.40.00.6100.0111	Communications- Landline	1,500		0	1,500	1,393	0		92.87
0033.40.00.6100.0112	Postage	300		0	300	198	0		66.00
0033.40.00.6100.1110	Communications- Wireless	1,260		0	1,260	425	0		33.73
0033.40.00.6200.0114	Advertising	200		0	200	0	0		0.00
0033.40.00.6400.0124	Travel Expense	100		0	100	0	0		0.00
0033.40.00.6500.0127	Electricity	413		0	413	187	0		45.28
0033.40.00.6500.0128	Water	503		0	503	254	0		50.50
0033.40.00.6500.0133	Stormwater	23,479		0	23,479	13,297	0		56.63
0033.40.00.6500.0134	Security Lights	989		0	989	560	0		56.62
0033.40.00.6500.1271	Electricity- Sales Tax	1		0	1	2	0		200.00
0033.40.00.6600.0133	Repairs & Maint. Services	63,429		0	63,429	5,603	0		8.83
0033.40.00.6600.0139	Fleet Services-RTA Mtce Allocati	17,000		0	17,000	2,725	0		16.03
0033.40.00.6600.0145	Gasoline & Oil	13,000		0	13,000	7,323	0		56.33
0033.40.00.6600.1391	Fleet Services -Departmental Exp	35,796		0	35,796	21,089	0		58.91
0033.40.00.6600.1392	Fleet Svcs- Outside Vends	5,000		0	5,000	4,509	0		90.18
0033.40.00.6700.0156	Equipment Rental/Lease	200		0	200	0	0		0.00
0033.40.00.6850.0180	Membership Dues and Fees	200		0	200	0	0		0.00
0033.40.00.6850.0182	Other Operating Expenses	26,890		0	26,890	174	0		0.65
0033.40.00.6850.0183	Depreciation	592,000		0	592,000	0	0		0.00
0033.40.00.6850.0186	Training	1,250		0	1,250	0	0		0.00
0033.40.00.6850.0190	Landfill Fees	40,000		0	40,000	1,575	0		3.94
0033.40.00.6860.0187	Professional Services	3,200		0	3,200	2,165	1,612		67.66
0033.40.00.6860.0189	Employee Medical	1,000		0	1,000	0	0		0.00
0033.40.00.6860.0196	Bank Charges/Fees	3,000		0	3,000	1,317	0		43.90
0033.40.00.6860.0199	Internal Engineering	53,339		0	53,339	28,381	0		53.21
0033.40.00.6860.1895	Employee wellness services	5,004		0	5,004	1,806	0		36.09
0033.40.00.6870.0202	Utility Billing Services	4,000		0	4,000	779	0		19.48
0033.40.00.6870.0204	Janitorial Services	908		0	908	0	0		0.00

BUDGET REPORT FOR CITY OF GEORGETOWN, SC
Calculations As of 01/31/2026

GL Number	Description	Original	25-26 Budget	25-26 Amended Budget Amt Change	25-26 Amended Budget	25-26 Activity	25-26 Encumbrance	% Budget	25-26 Used
Fund: 0033 Stormwater Utility Fund									
Account Category: Appropriations									
0033.40.00.7950.0995	GF Cost Distribution		73,810	0	73,810	43,056	0		58.33
0033.40.00.7950.0999	Allocation G&A Services		43,120	0	43,120	21,600	0		50.09
0033.40.00.9000.0956	Stormwater System Improvements E		300,000	0	300,000	1,620,367	900,750		540.12
0033.40.00.9000.1000	Infrastructure Improvemts		4,100,000	0	4,100,000	136,217	254,829		3.32
0033.40.00.9000.4200	Heavy Equipment		0	0	0	0	(423,301)		0.00
0033.40.00.9000.4300	Other Equipment		0	0	0	0	30,040		0.00
0033.40.00.9999.9999	Assets Reclassified		(4,400,000)	0	(4,400,000)	0	0		0.00
	Appropriations		<u>1,569,952</u>	<u>0</u>	<u>1,569,952</u>	<u>2,268,872</u>	<u>763,930</u>		<u>144.52</u>
Fund 0033 - Stormwater Utility Fund:									
	TOTAL ESTIMATED REVENUES		1,569,952	0	1,569,952	1,014,025	0		64.59
	TOTAL APPROPRIATIONS		<u>1,569,952</u>	<u>0</u>	<u>1,569,952</u>	<u>2,268,872</u>	<u>763,930</u>		<u>144.52</u>
	NET OF REVENUES & APPROPRIATIONS:		<u>0</u>	<u>0</u>	<u>0</u>	<u>(1,254,847)</u>	<u>(763,930)</u>		
			0.00%	0.00%	0.00%	-123.75%	0.00%		

BUDGET REPORT FOR CITY OF GEORGETOWN, SC
Calculations As of 01/31/2026

GL Number	Description	Original	25-26 Budget	25-26 Amended Amt Change	25-26 Budget	25-26 Activity	25-26 Encumbrance	% Budget	25-26 Used
Fund: 0035 Waste Management Fund									
Account Category: Estimated Revenues									
0035.00.00.3240.0007	Fees- Services		0	0	0	(97)	0		0.00
0035.00.00.3440.0001	Refuse Col Chge-Resident	1,186,708		0	1,186,708	753,119	0		63.46
0035.00.00.3440.0002	Refuse Col Chge-Comm	303,270		0	303,270	176,323	0		58.14
0035.00.00.3440.0003	Sanitation Fee Penalties	15,000		0	15,000	11,542	0		76.95
0035.00.00.3440.0006	Brown Goods Fees	200		0	200	(299)	0		(149.50)
0035.00.00.3610.0001	Investment Earnings	4,000		0	4,000	0	0		0.00
0035.00.00.3690.0002	Miscellaneous Revenue	50		0	50	89	0		178.00
0035.00.00.3690.0003	Insurance Proceeds	0		0	0	1,035	0		0.00
0035.00.00.3920.0004	From General Fund	92,135		0	92,135	0	0		0.00
	Estimated Revenues	1,601,363		0	1,601,363	941,712	0		58.81
Account Category: Appropriations									
0035.31.00.4000.0101	Regular Pay	497,000		0	497,000	164,881	0		33.18
0035.31.00.4010.0103	Overtime	9,000		0	9,000	13,748	0		152.76
0035.31.00.4050.0114	FICA	40,000		0	40,000	13,216	0		33.04
0035.31.00.4060.0116	Retirement	94,000		0	94,000	31,194	0		33.19
0035.31.00.4080.0125	SCMIT Worker's Comp Ins.	49,594		0	49,594	30,161	0		60.82
0035.31.00.4100.0001	Health Claims Cost	58,076		0	58,076	49,856	0		85.85
0035.31.00.4100.0002	Health Claim Costs-Retire	16,620		0	16,620	4,999	0		30.08
0035.31.00.5000.0101	Supplies and Materials	5,000		0	5,000	3,217	0		64.34
0035.31.00.5010.0101	Uniforms and Clothing	21,000		0	21,000	6,861	0		32.67
0035.31.00.5150.0121	Safety Supplies	5,250		0	5,250	3,771	0		71.83
0035.31.00.6000.0110	SCMIRF Property/Liab Ins	8,411		0	8,411	8,648	0		102.82
0035.31.00.6100.0111	Communications- Landline	300		0	300	0	0		0.00
0035.31.00.6100.0112	Postage	1,000		0	1,000	400	0		40.00
0035.31.00.6100.1110	Communications- Wireless	2,400		0	2,400	0	0		0.00
0035.31.00.6200.0114	Advertising	1,500		0	1,500	84	0		5.60
0035.31.00.6400.0124	Travel Expense	800		0	800	0	0		0.00
0035.31.00.6500.0127	Electricity	1,040		0	1,040	965	0		92.79
0035.31.00.6500.0128	Water	1,311		0	1,311	607	0		46.30
0035.31.00.6500.0129	Wastewater	1,559		0	1,559	726	0		46.57
0035.31.00.6500.0130	Sanitation	456		0	456	258	0		56.58
0035.31.00.6500.0133	Stormwater	79		0	79	45	0		56.96
0035.31.00.6500.0134	Security Lights	543		0	543	307	0		56.54
0035.31.00.6500.1271	Electricity- Sales Tax	2		0	2	2	0		100.00
0035.31.00.6600.0139	Fleet Services-RTA Mtce Allocati	40,000		0	40,000	19,589	0		48.97
0035.31.00.6600.0145	Gasoline & Oil	55,000		0	55,000	18,164	0		33.03
0035.31.00.6600.1391	Fleet Services -Departmental Exp	94,654		0	94,654	52,558	0		55.53
0035.31.00.6600.1392	Fleet Svcs- Outside Vends	5,000		0	5,000	972	0		19.44
0035.31.00.6810.0100	Capital Lease Principal	32,610		0	32,610	32,610	0		100.00
0035.31.00.6810.0120	Capital Lease Interest	3,366		0	3,366	842	0		25.01
0035.31.00.6850.0180	Membership Dues and Fees	600		0	600	190	0		31.67
0035.31.00.6850.0182	Other Operating Expenses	3,300		0	3,300	682	0		20.67
0035.31.00.6850.0183	Depreciation	136,750		0	136,750	0	0		0.00
0035.31.00.6850.0186	Training	1,500		0	1,500	95	0		6.33
0035.31.00.6850.0190	Landfill Fees	1,000		0	1,000	0	0		0.00
0035.31.00.6860.0189	Employee Medical	800		0	800	0	0		0.00
0035.31.00.6860.0195	Repair/Maint Svc Contract	6,300		0	6,300	244	0		3.87
0035.31.00.6860.0196	Bank Charges/Fees	4,000		0	4,000	1,581	0		39.53
0035.31.00.6860.1895	Employee wellness services	7,996		0	7,996	2,853	0		35.68

BUDGET REPORT FOR CITY OF GEORGETOWN, SC
Calculations As of 01/31/2026

GL Number	Description	Original	25-26 Budget	25-26 Amended Budget Amt Change	25-26 Budget	25-26 Activity	25-26 Encumbrance	% Budget	25-26 Used
Fund: 0035 Waste Management Fund									
Account Category: Appropriations									
0035.31.00.6870.0202	Utility Billing Services		6,000	0	6,000	1,576	0		26.27
0035.31.00.6870.0203	Contract Services		155,000	0	155,000	51,372	35,515		33.14
0035.31.00.6870.0204	Janitorial Services		4,860	0	4,860	1,620	810		33.33
0035.31.00.7020.0105	Interest on Bonds		23,218	0	23,218	(15,479)	0		(66.67)
0035.31.00.7020.0110	Bond Principal		20,400	0	20,400	0	0		0.00
0035.31.00.7030.1001	Agent Fees		385	0	385	0	0		0.00
0035.31.00.7300.0120	Recycling Labor		53,000	0	53,000	20,946	32,054		39.52
0035.31.00.7300.0122	Recycling Operating		8,000	0	8,000	5,234	0		65.43
0035.31.00.7950.0001	IT Internal Allocations		12,122	0	12,122	7,488	0		61.77
0035.31.00.7950.0995	GF Cost Distribution		130,364	0	130,364	76,046	0		58.33
0035.31.00.7999.9999	Principal Reclassified		(20,400)	0	(20,400)	0	0		0.00
0035.31.00.9000.3000	Buildings & Improvements		315,726	0	315,726	83,278	179,107		26.38
0035.31.00.9000.4200	Heavy Equipment		350,000	0	350,000	323,830	0		92.52
0035.31.00.9000.4300	Other Equipment		110,000	0	110,000	17,223	28,746		15.66
0035.31.00.9999.9999	Assets Reclassified		(775,726)	0	(775,726)	0	0		0.00
0035.32.00.4100.0001	Health Claims Cost		597	0	597	0	0		0.00
	Appropriations		1,601,363	0	1,601,363	1,037,460	276,232		64.79
Fund 0035 - Waste Management Fund:									
	TOTAL ESTIMATED REVENUES		1,601,363	0	1,601,363	941,712	0		58.81
	TOTAL APPROPRIATIONS		1,601,363	0	1,601,363	1,037,460	276,232		64.79
	NET OF REVENUES & APPROPRIATIONS:		0	0	0	(95,748)	(276,232)		
			0.00%	0.00%	0.00%	-10.17%	0.00%		
Report Totals:									
	TOTAL ESTIMATED REVENUES - ALL FUNDS		54,526,593	0	54,526,593	27,262,792	0		50.00
	TOTAL APPROPRIATIONS - ALL FUNDS		54,526,593	0	54,526,593	33,659,930	16,587,648		61.73
	NET OF REVENUES & APPROPRIATIONS:		0	0	0	(6,397,138)	(16,587,648)		
			0.00%	0.00%	0.00%	-23.46%	0.00%		

Active Businesses				
Business	Type of Business	Source	Status	Last Worked
109-111 SCREVEN STREET LLC	Commercial Property Owner	ParcelData2025 - Inside City	MAIL SENT	9/4/2025
1108 DUKE LLC	Commercial Property Owner	ParcelData2025 - Inside City	MAIL SENT	9/4/2025
1311 CHURCH STREET LLC	Commercial Property Owner	ParcelData2025 - Inside City	PAID-INITIAL	9/30/2025
1380 NORTH FRASER LLC	Commercial Property Owner	ParcelData2025 - Inside City	MAIL SENT	9/4/2025
1706 HIGHMARKET LLC	Commercial Property Owner	ParcelData2025 - Inside City	MAIL SENT	9/4/2025
2104 SOUTH FRASER LLC	Commercial Property Owner	ParcelData2025 - Inside City	PAID-INITIAL	2/6/2026
235 CHURCH STREET LLC	Commercial Property Owner	ParcelData2025 - Inside City	MAIL SENT	9/4/2025
300 North Fraser LLC	Commercial Property Location	City Vendor List 08/2025	Needs Mail Sent	2/5/2026
301 CHURCH STREET LLC	Commercial Property Owner	ParcelData2025 - Inside City	MAIL SENT	12/15/2025
3Chords Inc	Staffing agency for school districts, clinicians, and educators	Business Requested	PAID-2ND RENEWAL	7/16/2025
3M Company	Lease Equipment	Georgetown County Business Personal Property Tax	ONE AT A TIME	2/12/2026
413 CANNON ST LLC	Commercial Property Owner	ParcelData2025 - Inside City	MAIL SENT	9/4/2025
511 PRINCE STREET LLC	Commercial Property Owner	ParcelData2025 - Inside City	MAIL SENT	9/4/2025
632 FRONT STREET LLC	Commercial Property Owner	ParcelData2025 - Inside City	MAIL SENT	9/4/2025
718 FRONT STREET HOLDINGS LLC	Commercial Property Owner	ParcelData2025 - Inside City	MAIL SENT	9/4/2025
A&A Refrigeration	Commercial refrigeration installation/repair/maintenance, HVAC services, commercial kitchen equipment and hood systems, ice machine rental and leasing	Client Referral	APPLICATION-INITIAL	10/24/2025
A&A Seamless Gutters	Gutter installation and cleaning	City Vendor List	APPLICATION-INITIAL	2/4/2026
A&S HOLDINGS LLC	Commercial Property Owner	ParcelData2025 - Inside City	MAIL SENT	9/4/2025
A3 Communications Inc	Networking, Security and Communcations	Georgetown County Schools Transparencies Jan-April 2023	PAID-INITIAL	7/16/2025
AABC DOWNTOWN PAWLEYS ISLAND LLC	Commercial Property Owner	ParcelData2025 - Inside City	Addr Complete/Pending apps	11/24/2025
Abbie US LLC	Lessor of Medical Equipment	Georgetown Business Personal Property Tax	PAID-INITIAL	10/30/2024
ABM Industries dba ABM Electrical Power Services LLC	Facility Management and Cleaning	Common Business	PAID-2ND RENEWAL	7/16/2025
Active Glass and Mirror (AG&M)	Commercial and residential glass services	City Vendor List	APPLICATION-INITIAL	2/4/2026
ADDESTONE LLC	Commercial Property Owner	ParcelData2025 - Inside City	MAIL SENT	9/4/2025
ADP, Inc.	Payroll Processing	City Vendor List	PAID-2ND RENEWAL	7/16/2025
ADT Commercial LLC (The ADT Security Corporation)	Commercial Electronic Security Svcs.	Georgetown County Business Personal Property Tax	PAID-2ND RENEWAL	7/16/2025
AED Brands LLC	First aid equipment and defibrillators. Provide on-site inspections	Georgetown Combined Muni Lists	Multiple Attempts	10/13/2025
Agri South Inc	Farm & Garden Supplies/Equipment	Georgetown All Proof Combined	APPLICATION-1ST FOLLOW UP	10/15/2025
All Source Enterprises, LLC (DBA Safe Industries)	Fire protection	Common Business	PAID-2ND RENEWAL	7/16/2025
Allied 100 LLC (Cardio Partners / Sarnova)	Medical Device Company	Georgetown All Proof Combined	PAID-INITIAL	2/6/2026
ALLSTON PYATT HOLDINGS LLC	Commercial Property Owner	ParcelData2025 - Inside City	Addr Complete/Pending apps	11/18/2025
Al-Tar	Cold storage, histology, calibration, on-site lab equipment repair, centrifuge services, lab balances	City Vendor List	APPLICATION-INITIAL	2/26/2026
Altec Industries	Electric utility products	City Vendor List	PAID-INITIAL	7/8/2024
American Builders & Contractors Supply dba ABC Supply Co	Distributor of roofing, siding, windows, gutters and more	City Vendor List	PAID-2ND RENEWAL	9/30/2024
American Greeting Corp	Greeting cards-Marketing services	Common Business	PAID-2ND RENEWAL	7/16/2025
American Tire Distributors (ATD)	HOLD - Tire supplier, Have own company fleet of vehicles for delivery	Common Business	PAID-INITIAL	12/16/2024
Amplify Education	Professional School Teacher Development plan and Tech Support	Georgetown County School Transparency List	PHONE CALL	2/10/2026
AP HOSPITALITY INC	Commercial Property Owner	ParcelData2025 - Inside City	MAIL SENT	9/4/2025

Apex Learning	Digital Curriculum Consulting	Georgetown County School Transparency List	APPLICATION-INITIAL	2/3/2026
Apple Inc	Technology /software	Georgetown County School Transparency	PAID-INITIAL	11/5/2025
APPLECOOL SELF STORAGE LLC	Commercial Property Owner	ParcelData2025 - Inside City	MAIL SENT	9/4/2025
AquaFix Inc	Wastewater technology, lab services, product supplier. Sales reps	City Vendor List	PAID-INITIAL	4/7/2025
Arc3 Gases South	Welding Products and Gases, rentals and repairs	Common Business	PAID-2ND RENEWAL	7/16/2025
Ascentium Capital LLC	Finance new and used equipment	Common Business	PAID-2ND RENEWAL	7/16/2025
ATCO International	Distributor of maintenance products	City Vendor List	PAID-2ND RENEWAL	7/16/2025
Augusta Concrete Block Company	Manufacturer of Concrete Blocks, Reatining Wall Services	Discovery	Multiple Attempts	3/3/2026
Augusta Fiberglass Coatings Inc	Engineering & Field service, repair, and maintenance	City Vendor List	APPLICATION-INITIAL	2/9/2026
Baker Distributing Company	Equipment & Supplies. Have own company fleet of vehicles for delivery	Business requested	PAID-INITIAL	6/10/2024
BARREL PROPERTIES LLC DBA SMK HOLDINGS LLC	Commercial Property Owner	ParcelData2025 - Inside City	MAIL SENT	9/4/2025
Beard Equipment Company	Golf and sports turf equipment supplier, repairs, rentals, have own company vehicles	Discovery	Multiple Attempts	2/9/2026
Beckman Coulter Inc	Lease medical equipment	Common Business	PAID-2ND RENEWAL	7/16/2025
BENSTON PROPERTIES LLC	Commercial Property Owner	ParcelData2025 - Inside City	MAIL SENT	9/4/2025
BHSFF SOUTH CAROLINA LLC	Commercial Property Owner	ParcelData2025 - Inside City	MAIL SENT	9/4/2025
Binswanger Enterprises, LLC	Glass & Repair	Common Business	PAID-2ND RENEWAL	7/16/2025
Blossman Gas and Appliance	Propane gas, appliance and service	Common Business	PAID-2ND RENEWAL	7/16/2025
Blue Triton Brands dba Ready Refresh	Bottled water delivery	Georgetown All Proof Combined	Verifying Liability	3/2/2026
Bobby's Appliance Center	Appliances and mattress sale. Home delivery and installation. Appliance repair	Georgetown County School Transparency List	APPLICATION-INITIAL	2/4/2026
Bobcat of Myrtle Beach SC	Equipment Sales, Rental, Parts & Service	City Vendor List 09-2025	NEW ACCOUNT LOAD	1/16/2026
BOCAT HOLDINGS I LLC	Commercial Property Owner	ParcelData2025 - Inside City	MAIL SENT	9/4/2025
Bolton and Menk	surveying and engineering services	City Vendor List 09-2025	APPLICATION-INITIAL	2/9/2026
BONNIE B BAYLEY	Commercial Property Owner	ParcelData2025 - Inside City	Addr Complete/Pending apps	11/18/2025
Boston Scientific Corp	DNA - Surgical Supplies	Common Business	PAID-2ND RENEWAL	7/16/2025
Bound Tree Medical, LLC	Medical Supply for Emergency Services. Sales reps	Georgetown All Proof Combined	PAID-INITIAL	8/28/2025
Brainpop	Technology Services	Georgetown County School Transparency September 2024	Needs Mail Sent	2/11/2026
Brenntag Mid-South Inc	Chemical distribution	Georgetown County Vendor List	APPLICATION-INITIAL	2/9/2026
BRG LLC	Commercial Property Owner	ParcelData2025 - Inside City	MAIL SENT	9/4/2025
Bridgetek Solutions LLC	Equipment/software technology	Georgetown County Schools Transparencies Jan-April 2023	ONE AT A TIME	2/26/2026
Brink's Incorporated	Armored truck services	Common Business	PAID-2ND RENEWAL	7/16/2025
Britton Landscaping LLC		Georgetown County Vendor List	Multiple Attempts	10/13/2025
BROWNE TROY	Parcel Data Owner	Parcel Data Owner	Needs Mail Sent	9/2/2025
Busch Systems International Inc	Recycling and waste containers	City Vendor List 09-2025	APPLICATION-INITIAL	2/9/2026
Business Information Systems Inc dba BIS Digital Inc	Digital recording solutions. Field technicians install and repair	Georgetown All Proof Combined	APPLICATION-1ST FOLLOW UP	10/20/2025
C C FERRER LLC	Parcel Data Owner	Parcel Data Owner	PAID-INITIAL	3/3/2026
C&S Solutions Inc	Locating, Inspecting, & Fault Finding Utilities Equipment, on-site training and demonstration	City Vendor List	MAIL SENT	11/22/2025
Camden Fire Extinguishers Services	Fire Extinguishers Installation, Test, Repair, Services, and Inspections	Common Business	PAID-2ND RENEWAL	7/16/2025
Cannon Technologies	Data Center Installation	City Vendor List 08/2025	APPLICATION-INITIAL	3/9/2026
Canon Financial Services Inc	Lease office equipment	Common Business	PAID-2ND RENEWAL	7/16/2025
Cantey Gutters	HOLD - Residential Gutter Installations and Repairs	Discovery	Multiple Attempts	12/23/2025
Capitol Materials Coastal	Construction materials and equipment supplier, safety and site reviews, delivery via own company fleet of vehicles	Georgetown County Vendor List	Needs Mail Sent	2/28/2026

Caplea Coe Architects Inc	Technology solutions and architectural services	City Vendor List 8/2024	PAID-INITIAL	9/18/2025
Carahsoft Technology Corporation	Government IT solutions provider	Georgetown All Proof Combined	ONE AT A TIME	2/27/2026
Carolina Electrical Supply Company (CESCO)	Commercial, residential, and industrial lighting + design services, delivery offered	Georgetown All Proof Combined	APPLICATION-1ST FOLLOW UP	10/20/2025
Carolina International Trucks, Inc.	Sells and services medium, heavy, and severe service International Trucks, IC Buses, delivery via company own fleet. Truck lease and rentals	City Vendor List	APPLICATION-INITIAL	12/16/2025
Carolina Office Systems Inc	Computer and office machine repair	Common Business	PAID-2ND RENEWAL	7/16/2025
Carolina Parks and Play	playgrounds, splash pads, site furnishings, shade products	City Vendor List 8/2024	PAID-INITIAL	4/9/2025
Carolina Recording Systems	Voice recording systems, on-site support, on-site preventative maintenance	Common Business	PAID-INITIAL	2/6/2025
Carolina Shine LLC	Cleaning supplies distributor, deliver via own company trucks, travelling sales reps	City Vendor List	MAIL SENT	12/4/2025
CATTLEYA INVESTMENTS LLC	Parcel Data Owner	Parcel Data Owner	Needs Mail Sent	9/2/2025
CDW Government Inc	IT Services	Georgetown County School Transparency November 2024	APPLICATION-2ND FOLLOW UP	11/20/2025
CECCHINE GLENN D CECCHINE CAROL A	Parcel Data Owner	Parcel Data Owner	Needs Mail Sent	9/2/2025
CENTURY PROPERTIES XXVI LIMITED PS	Parcel Data Owner	Parcel Data Owner	PAID-INITIAL	12/3/2025
CGB LIMITED PARTNERSHIP	Parcel Data Owner	Parcel Data Owner	Needs Mail Sent	9/2/2025
Charge POINT Charging Station	Electric Vehicle Charging Station-1116 S Main St, Laurens, SC 29360	Georgetown All Proof Combined	NEW ACCOUNT LOAD	10/17/2025
City Works Equipment and Supply dba Southern Vac	Equipment Rental and Routine Maintenance On-Site	City Vendor List 10-2025	APPLICATION-2ND FOLLOW UP	1/13/2026
ClassLink	Identity and access management technology services, learning analytics,	Georgetown County School Transparency July 2024	PHONE CALL	2/24/2026
Clean Image Pressure Washing	Pressure washing and exterior cleaning	City Vendor List 10-2025	APPLICATION-INITIAL	12/31/2025
CMK PROPERTIES LLC	Parcel Data Owner	Parcel Data Owner	PAID-INITIAL	12/3/2025
Co B LLC	Parcel Data Owner	Parcel Data Owner	Needs Mail Sent	9/2/2025
Coast 2 Coast Lawns LLC	Land maintenance and lawn care	Georgetown County School Transparency List	APPLICATION-INITIAL	2/5/2026
Coastal Capital Leasing	Copy Machine Leasing	Business	PAID-RENEWAL	6/10/2024
Coastal Sanitary Supply Co, Inc	Janitorial supplies, Floor equipment, training & maintenance, ship locally and regionally on own fleet trucks	Georgetown County School Transparency 2021 & 2023-2024	APPLICATION-INITIAL	2/12/2026
Coastal Staffing Services LLC	Staffin	City Vendor List	PAID-INITIAL	8/30/2023
Coastal Wire Company	Coil wire, box wire, high tensile galvanized wire. equipment parts and equipment service	Georgetown County Vendor List	MAIL SENT	12/4/2025
CodeLynx	Audio visual and physical security design and installation for A/V, access control and video surveillance	Georgetown County School Transparency List	APPLICATION-INITIAL	2/19/2026
CoinCloud (Cash Cloud, Inc)	Bitcoin atm rental	Common Business	PAID-2ND RENEWAL	7/16/2025
Coleman Worldwide Moving	Local, Long Distance, & International Moving Services	Discovery	APPLICATION-2ND FOLLOW UP	11/20/2025
Colonial Oil Industries Inc (COI Inc)	Fuel services and fuel delivery, lubricants	City Vendor List 07-2025	APPLICATION-INITIAL	2/9/2026
Combs and Associates (Combs Technologies Inc)	Equipment for Water and Waterwater Treatment. Territory sales reps	City Vendor List	APPLICATION-INITIAL	2/4/2026
Community Design Solutions	Community Design & Planning services	City Vendor List	Needs Mail Sent	2/23/2026
ComputerPlus Sales and Service Inc	Systems maintenance, hardware contract maintenance, managed imac services, depot repair and advanced exchange, printer equipment and supplies, on-site services	City Vendor List	APPLICATION-INITIAL	2/4/2026
Concrete Designs LLC	Precast Concrete, Delivery, and Install	City Vendor List	PAID-RENEWAL	7/16/2025
Consensus Construction and Consulting Inc	General Contractor	City Vendor List 2024	MAIL SENT	11/22/2025

CONSOLIDATED ELECTRICAL DISTRIBUTORS, INC.	Maintenance and Repairs	City Vendor List 08/2025	APPLICATION-INITIAL	3/9/2026
Consolidated Pipe & Supply Company, Inc.	Pipe, Valve & Fitting Products and Services	City Vendor List	PAID-2ND RENEWAL	7/16/2025
Construction Materials Group	Construction materials supplier. Delivery offered	Georgetown County Vendor List	MAIL SENT	12/8/2025
Conway Rental Center (CRC)	Party and equipment rental	City Vendor List	PAID-INITIAL	3/19/2025
Cook and Boardman LLC	Hardware Distribution, fire door inspection and installation, on-site diagnostic service, custom fabrication and welding, project management	Georgetown County School Transparency 2021 & 2023-2024	PAID-INITIAL	4/2/2025
Core & Main LP	Maintenance & repairs	Common Business	PAID-2ND RENEWAL	7/16/2025
Crane 1 Services Inc	Maintenance/Repair and Training on Hoist and Cranes. Have own company fleet of vehicles.	City Vendor List	ADDRESS REQUEST	8/15/2025
CSC Leasing Company	Equipment leasing and financing	Georgetown County Business Personal Property Tax	ONE AT A TIME	2/10/2026
CSC Serviceworks Inc	Lease Equipment	Common Business	PAID-2ND RENEWAL	7/16/2025
CSI Leasing	DNA KY- Lease Equipment	Common Business	PAID-2ND RENEWAL	7/16/2025
D&W Sitework LLC	Demolition and Excavation services	City Vendor List	APPLICATION-INITIAL	2/4/2026
Daikin Applied Americas Inc.	Commercial HVAC systems for heating, ventilation and air conditioning	Common Business	PAID-2ND RENEWAL	7/16/2025
Dana Safety Supply Inc	major warehousing distributor, seller, service provider, and installer of law enforcement and public safety	Georgetown All Proof Combined	Multiple Attempts	8/6/2025
DANCING MULLETT LLC	Parcel Data Owner	Parcel Data Owner	Needs Mail Sent	9/2/2025
DANIELS HOLDINGS	Parcel Data Owner	Parcel Data Owner	Needs Mail Sent	9/2/2025
DARCOM LLC	Parcel Data Owner	Parcel Data Owner	Needs Mail Sent	9/2/2025
Dawson Lumber Company	Lumber and building materials supplies. Delivery offered	City Vendor List	APPLICATION-INITIAL	3/3/2026
DCS PROPERTIES LLC ZOERB DONITA TRUSTEE	Parcel Data Owner	Parcel Data Owner	Needs Mail Sent	9/2/2025
De Lage Landen Financial Services	Lease Equipment	Common Business	PAID-2ND RENEWAL	7/16/2025
DEBIDUE CREEK LLC	Parcel Data Owner	Parcel Data Owner	Needs Mail Sent	9/2/2025
DEBORDIEU BELLES LLC	Parcel Data Owner	Parcel Data Owner	Verifying Liability	11/18/2025
Dell Marketing LP	Technology/Software-Retail	City Vendor List	PAID-INITIAL	6/2/2025
Dependable Service Plumbing and Air Inc	HVAC and plumbing services	City Vendor List	PAID-RENEWAL	9/30/2024
DG GEORGETOWN LLC	Parcel Data Owner	Parcel Data Owner	CALCULATION SENT	1/14/2026
DHSP VENTURES LLC A SC LLC	Parcel Data Owner	Parcel Data Owner	Needs Mail Sent	9/2/2025
Digitalmint Bitcoin ATM	Bitcoin ATM	Common Business	AVENUE EXHAUSTED	11/22/2025
Dish Network LLC	DNA - Satellite service provider	Georgetown County Business Personal Property Tax	PAID-2ND RENEWAL	7/16/2025
DocuSystems Inc	Office copiers and equipment, managed IT, managed print services, document management service	City Vendor List	PAID-2ND RENEWAL	7/16/2025
Don Moorhead Construction Inc.	General Contractor	City Vendor List 09-2025	APPLICATION-INITIAL	2/9/2026
DP CAPITAL LLC	Parcel Data Owner	Parcel Data Owner	Needs Mail Sent	9/2/2025
DUNCAN DEVELOPMENT LLC	Parcel Data Owner	Parcel Data Owner	Needs Mail Sent	9/2/2025
Duplicates Ink	Marketing consultant in Conway, SC	Georgetown All Proof Combined	NEW ACCOUNT LOAD	10/17/2025
Eadie's Construction Company Inc	Storm drain install/repair, sewer main install/repair, water main install/repair, sewer lift station install/repair, hydrant install/repair, jack and bore, directional drilling, septic systems, box culverts, demolition	City Vendor List	Multiple Attempts	2/20/2026
Eadie's Industrial Inc	Industrial Vacuum services, combo sewer jet, sewer lift stations, water blasting, storage tank cleaning, video/camera inspections, drainage maintenance, remediation services	City Vendor List	APPLICATION-INITIAL	2/5/2026
EAGLE PARTNERS LLC	Parcel Data Owner	Parcel Data Owner	PAID-INITIAL	12/3/2025

East Coast Metal Distributors	HVAC product suppliers. Deliver via own truck	Common Business	PAID-INITIAL	2/8/2023
Eastland Pest Control	Pest control service	Georgetown County School Transparency List	APPLICATION-INITIAL	2/5/2026
Eckberg Enterprises Inc.	Plumbing services	Georgetown County School Transparency List	PAID-INITIAL	7/16/2025
Edmentum, Inc.	Educational computer software (dba Plato Learning)	Georgetown County School Transparency 02/2025	ONE AT A TIME	2/11/2026
EDWARDS JAMES B III EDWARDS JOYCE T	Parcel Data Owner	Parcel Data Owner	Addr Complete/Pending apps	11/18/2025
Elliott's Stump Grinding (Kevin Elliot's Stump Grinding)	Tree stump and root clearing	Georgetown County Vendor List	MAIL SENT	11/22/2025
Empire Marketing Group	Management, Scientific, and Technical Consulting Services, Professional, Scientific, and Technical Services, Marketing consulting	Georgetown All Proof Combined	APPLICATION-INITIAL	11/3/2025
EMR Services Inc	Demolition, Mold, Asbestos and Lead	City Vendor List 08/2025	APPLICATION-INITIAL	3/9/2026
Environmental Express	Development and manufacture of sample collection, preparation, single use consumables and analysis equipment	Georgetown All Proof Combined	APPLICATION-1ST FOLLOW UP	12/4/2025
ESKENAZI JILL	Parcel Data Owner	Parcel Data Owner	Needs Mail Sent	9/2/2025
Esri Inc. (Environmental Systems Research Institute)	Consulting, Geo Spatial Mapping	City Vendor List	APPLICATION-INITIAL	2/5/2026
ETHRIDGE PATSY M ETHRIDGE PATRICK T	Parcel Data Owner	Parcel Data Owner	Needs Mail Sent	9/2/2025
ETHRIDGE PATSY M TRUSTEE	Parcel Data Owner	Parcel Data Owner	Needs Mail Sent	9/2/2025
Event Works Rentals (Peach Tree Tents and Events LLC)	Event Rentals, Tent Set Up, Consultation and Delivery	Georgetown County School Transparency List	PAID-2ND RENEWAL	7/16/2025
eXp Realty LLC	Real estate agency	Client Referral	APPLICATION-INITIAL	10/24/2025
Exxon Mobil	Gas stations and supplier	Georgetown All Proof Combined	APPLICATION-INITIAL	11/3/2025
FABIAN JOSEPH	Parcel Data Owner	Parcel Data Owner	Needs Mail Sent	9/2/2025
FEAGIN LARRY	Parcel Data Owner	Parcel Data Owner	Needs Mail Sent	9/2/2025
FEAGIN LARRY L ET AL FEAGIN LINDA H	Parcel Data Owner	Parcel Data Owner	Needs Mail Sent	9/2/2025
Ferrellgas LP (dba Blue Rhino)	Propane supplier	Common Business	PAID-2ND RENEWAL	7/16/2025
Fleur de la mer Gtown LLC	Parcel Data Owner	Parcel Data Owner	PAID-INITIAL	1/1/2026
Flock Group Inc.	Public safety solutions, surveillance/safety camera installation and maintenance	Georgetown County Vendor List	PAID-RENEWAL	7/16/2025
Focus 5 Inc	Professional learning opportunities and program consulting focused on aligning arts integration, best instructional practices, and current thinking in the field of arts and education	Georgetown County School Transparency 02/2025	APPLICATION-1ST FOLLOW UP	9/4/2025
FORD F B JR	Parcel Data Owner	Parcel Data Owner	Needs Mail Sent	9/2/2025
FORD FRANCIS BELL JR CO TRUSTEE STOTT MARY LOUISE FORD CO-TRUSTEE	Parcel Data Owner	Parcel Data Owner	Needs Mail Sent	9/2/2025
Fortiline Waterworks	Underground Water, Sewer and Storm Drain Utility Products	City Vendor List 8/2024	Verifying Liability	2/23/2026
Franklin Baking Company, LLC	Produces bread, rolls, cakes, and donuts, It operates direct-store-delivery routes	Georgetown Combined Muni Lists	APPLICATION-2ND FOLLOW UP	12/4/2025
Frontier Communications	Telecommunications Services	Georgetown All Proof Combined	APPLICATION-INITIAL	11/3/2025
Frye Mobile Homes	Mobile home sales and rentals	Client Referral	Needs Mail Sent	10/24/2025
FujiFilm North America Corporation	Medical imaging Equipment	Common Business	PAID-RENEWAL	7/16/2025
G Meetze Construction, LLC	General contractor	Discovery	Multiple Attempts	10/2/2025
G3 Engineering & Surveying LLC	Civil engineering, land surveying, site planning services, landscape architecture & land development consulting	City Vendor List 8/2024	PAID-INITIAL	3/31/2025
GARCIA ROBERTO GARCIA ANGELICA	Parcel Data Owner	Parcel Data Owner	Needs Mail Sent	9/2/2025
Garda CL East Inc (GardaWorld)	Armored truck services	Discovery	PAID-INITIAL	5/22/2025
GEATHERS DEON	Parcel Data Owner	Parcel Data Owner	Needs Mail Sent	9/2/2025

Genco Inc	Janitorial Supplies, Food Service, Facility and Grounds Maintenance. Deliver via own company fleet	Georgetown County School Transparency September-November 2024	Needs Mail Sent	2/20/2026
Geo Fras	New owner of property	Parcel Data Property Owner	NEW ACCOUNT LOAD	11/3/2025
GEORGETOWN DEVELOPERS LLC	Commercial Property Owner	ParcelData2025 - Inside City	MAIL SENT	9/4/2025
Georgetown Shutter Shop	Shutter manufacturing	Business Requested	PAID-INITIAL	11/5/2025
GEORGIA SKY LLC	Parcel Data Owner	Parcel Data Owner	Needs Mail Sent	9/2/2025
GeoTAC HOLDINGS LLC	Parcel Data Owner	Parcel Data Owner	Needs Mail Sent	9/2/2025
GEOTAC II HOLDINGS LLC	Parcel Data Owner	Parcel Data Owner	Needs Mail Sent	9/2/2025
Gibson Supply Inc	Water works equipment supplier	Georgetown All Proof Combined	PAID-INITIAL	2/6/2026
GILLAM ENTERPRISES LLC	Parcel Data Owner	Parcel Data Owner	PAID-INITIAL	12/3/2025
Graham's Golf Cars Inc	Golf cart sales, service, rentals, new and used parts	City Vendor List	PAID-INITIAL	4/2/2025
Granicus	cloud-based solution for communications, meeting and agenda management, and digital services. On-site training and installation. Travelling sales reps	City Vendor List 08-2025	APPLICATION-INITIAL	3/9/2026
GRANT MARY L A	Parcel Data Owner	Parcel Data Owner	Needs Mail Sent	9/2/2025
Graybar Electric Company	Electrical apparatus and equipment	Georgetown County School Transparency 02/2025	Multiple Attempts	10/2/2025
Great Security LLC	Serving security solutions	City Vendor List 09-2025	NEW ACCOUNT LOAD	1/16/2026
GREEN BRITTANI	Parcel Data Owner	Parcel Data Owner	Needs Mail Sent	9/2/2025
GREEN JULIE PARKER ET AL GREEN MARY GILLIAN RAE	Parcel Data Owner	Parcel Data Owner	PAID-INITIAL	2/6/2026
GREENE YVONNE	Parcel Data Owner	Parcel Data Owner	Needs Mail Sent	9/2/2025
GSI-Generator Services Inc	Sales, service and repair	Common Business	PAID-2ND RENEWAL	7/16/2025
GW Services Inc	Regime and association management, rentals and real estate sales, home inspections, interior and exterior remodeling, contact maintenance	City Vendor List	MAIL SENT	11/22/2025
GXC Inc	Armed and unarmed security personnel, metal detectors, rental services with on site setup	Georgetown County School Transparency List	PAID-2ND RENEWAL	7/16/2025
H&E Equipment Services	Earthmoving, construction, industrial, material handling, and heavy equipment rental	Georgetown County School Transparency List	PAID-2ND RENEWAL	7/16/2025
Hallmark Marketing Company LLC	Greeting cards, gift wrap, ornaments & gifts	Common Business	PAID-2ND RENEWAL	7/16/2025
HAMLIN KAREN JOETTA OWENS THERESA HAMLIN TRTEE	Parcel Data Owner	Parcel Data Owner	PAID-INITIAL	10/27/2025
HARDWICK AUTOS LLC	Parcel Data Owner	Parcel Data Owner	Needs Mail Sent	9/2/2025
HARDWICK PROPERTIES II LLC	Parcel Data Owner	Parcel Data Owner	Needs Mail Sent	9/2/2025
Hardwick's Landscaping LLC	Excavating and landscaping services	Georgetown County School Transparency List	PAID-RENEWAL	7/16/2025
HARRISON SELENA T	Parcel Data Owner	Parcel Data Owner	Needs Mail Sent	9/2/2025
HCA Healthcare (Hospital Corporation of America)	Healthcare facility operator	Discovery	AVENUE EXHAUSTED	6/4/2025
Heartful Hearts in Home Care	Non-Medical In Home Care Agency	Client Referral	APPLICATION-INITIAL	10/24/2025
Helena Chemical Company (Helena Agri-Enterprises LLC)	Services include: Custom seed treating, Product delivery, Custom application, Fertilizer, Plant tissue	Discovery	PAID-INITIAL	7/16/2025
HEMINGWAY H E JR	Parcel Data Owner	Parcel Data Owner	Needs Mail Sent	9/2/2025
HENRIETTA BARBER, TRUSTEE	Commercial Property Owner	ParcelData2025 - Inside City	MAIL SENT	9/4/2025
Herff Jones LLC	Sells educational recognition, achievement and motivational products/materials	Common Business	PAID-2ND RENEWAL	7/16/2025
Hershey Creamery Company	Ice Cream	Common Business	PAID-2ND RENEWAL	7/16/2025
HERSKOWITZ JEROME A HERSKOWITZ CATHERINE M	Parcel Data Owner	Parcel Data Owner	PAID-INITIAL	11/19/2025
Hill-Rom Company Inc	Lease Equipment	Common Business	AVENUE EXHAUSTED	11/4/2025
HOBCAW COMPANY LLC THE	Parcel Data Owner	Parcel Data Owner	Needs Mail Sent	9/2/2025

Hobgood Electric	Technical field services, industrial electrical contracting, apparatus repair services. Have own company fleet of vehicles	City Vendor List	APPLICATION-INITIAL	3/3/2026
Hoffman Hydronics LLC	HVAC And plumbing solutions	Discovery	WAITING ON PROOF RESPONSE-(disc	2/24/2026
Hometown Sheds	Metal sheds, wooden buildings, play sets, carports/garages, pre-owned sheds, dog kennels. Set-up and delivery	City Vendor List	APPLICATION-INITIAL	2/11/2026
HOPETOWN VILLAS LLC	Parcel Data Owner	Parcel Data Owner	Addr Complete/Pending apps	11/18/2025
Howard Engineering	Electrical Systems Consulting and Analysis	City Vendor List 08/2025	APPLICATION-INITIAL	3/9/2026
Howard Technology Solutions	Technology and Software Supply Sales	Georgetown All Proof Combined	APPLICATION-INITIAL	11/3/2025
HUDSON C A	Parcel Data Owner	Parcel Data Owner	Needs Mail Sent	9/2/2025
Huntington Technology Finance, now a part of Huntington National Bank	Equipment finance	Georgetown County Business Personal Property Tax	Multiple Attempts	3/2/2026
Hydro Conduit dba Rinker Materials	Building materials supplies	Georgetown County Vendor List	PAID-INITIAL	12/2/2024
Idexx DBA Idexx Laboratories DBA Idexx Distribution	Provide software, services, tools, and products for veterinarians	Georgetown All Proof Combined	APPLICATION-2ND FOLLOW UP	12/4/2025
III GNATS LLC	Parcel Data Owner	Parcel Data Owner	PAID-INITIAL	11/5/2025
Imperial Dade & Paper Co LLC	Supplies-Maintenance	Common Business	PAID-2ND RENEWAL	7/16/2025
Industrial Solutions and Supplies		City Vendor List	PAID-2ND RENEWAL	7/16/2025
INFOG LLC	Parcel Data Owner	Parcel Data Owner	Needs Mail Sent	9/2/2025
INTERNATIONAL PAPER CO	Parcel Data Owner	Parcel Data Owner & Georgetown All Proof Combined	Needs Mail Sent	9/2/2025
INTERNATIONAL PAPER CO INTERNATIONAL MILL	Parcel Data Owner	Parcel Data Owner	Needs Mail Sent	9/2/2025
INTERNATIONAL PAPER CO WOODLANDS OFFICE	Parcel Data Owner	Parcel Data Owner	Needs Mail Sent	9/2/2025
Internetwork Engineering	Engineer	Georgetown County School Transparency	Multiple Attempts	9/22/2025
Intrepid USA Healthcare Services	in-home healthcare, palliative care, and hospice services	Client Referral	APPLICATION-INITIAL	10/24/2025
IPOG LLC	Parcel Data Owner	Parcel Data Owner	Needs Mail Sent	9/2/2025
Iron Mountain Secure Shredding Inc	Document shredding services	City Vendor List 08/2025	APPLICATION-INITIAL	3/9/2026
Involved Talent Acquisition FKA Applicant Pro	Talent Acquisition	City Vendor List 08/2025	NEW ACCOUNT LOAD	2/5/2026
ISZARD LAMAR C/O MARCEL D BRIDGES SR	Parcel Data Owner	Parcel Data Owner	Needs Mail Sent	9/2/2025
J & S CONSULTANTS LLC	Parcel Data Owner	Parcel Data Owner	PENDING MUNICIPALITY	1/28/2026
J&M Electrical Service	Electrical contractor	Georgetown All Proof Combined	APPLICATION-INITIAL	12/8/2025
JACINEZ HOLDINGS LLC	Parcel Data Owner	Parcel Data Owner	Needs Mail Sent	9/2/2025
JCI Jones Chemicals Inc	re-packager of Chlorine and one of the largest Industrial Bleach manufacturers	City Vendor List	PAID-INITIAL	6/25/2024
Joe Johnson Equipment LLC	Sweeper repairs, rental equipment, on-site road technician repairs	Georgetown All Proof Combined	PAID-2ND RENEWAL	2/27/2026
JOHNSON ALDON L JOHNSON MARGIE A	Parcel Data Owner	Parcel Data Owner	Needs Mail Sent	9/2/2025
Johnson-Lambe Company	sports equipment jersey designs, trophies and awards, Sales reps in SC	Georgetown County School Transparency List	PAID-2ND RENEWAL	7/16/2025
KARRAS RENTAL PROPERTIES LLC	Parcel Data Owner	Parcel Data Owner	Addr Complete/Pending apps	12/29/2025
KCI USA, Inc. dba 3M Medical Solutions	Sell and rent medical equipment	Common Business	BIZ RESEARCHING	2/26/2026
Kelly Services Global LLC	Employment Agency	Georgetown County School Transparency List	PAID-2ND RENEWAL	7/16/2025
Kelly Services Inc	Employment Agency	Georgetown County School Transparency List	PAID-2ND RENEWAL	7/16/2025
Kelly Services USA LLC	Employment Agency	Georgetown County School Transparency List	PAID-2ND RENEWAL	7/16/2025
Kingston Electric	Commercial Electrician Services	Georgetown County Vendor List	PENDING APPLICATIONS	2/19/2026
KNOWLIN EVA ET AL MCCALLA DELICIA	Parcel Data Owner	Parcel Data Owner	Needs Mail Sent	9/2/2025
Konecranes Inc	Cranes services	Discovery	CALCULATION SENT	12/26/2025

Koppers Utility and Industrial Products	Utility poles and crossarms, 24/7 storm response, timber piling, lumber treatment types, have own company fleet of vehicles	City Vendor List 10-2025	NEW ACCOUNT LOAD	12/9/2025
L VAN HANDEL PROPERTIES LLC	Parcel Data Owner	Parcel Data Owner	Needs Mail Sent	9/2/2025
L&W Supply Corporation dba Acoustical & Drywall Supply (ABC Supply)	Products Supply/Delivery	Common Business	PAID-2ND RENEWAL	7/16/2025
LAMBERT BIRDELL LAMBERT MARY DAISY	Parcel Data Owner	Parcel Data Owner	Addr Complete/Pending apps	10/22/2025
LANCE ERIC ET AL	Parcel Data Owner	Parcel Data Owner	Needs Mail Sent	9/2/2025
Language Line Services, Inc	Onsite Translators	Georgetown County Vendor List	ONE AT A TIME	1/7/2026
LAREAU NEIL W	Parcel Data Owner	Parcel Data Owner	Needs Mail Sent	9/2/2025
LAWRIMORE CHALMERS P JR ET AL LAWRI MORE CONSTANCE F	Parcel Data Owner	Parcel Data Owner	Needs Mail Sent	9/2/2025
Leading Up LLC	On-site professional and personal development	Georgetown County School Transparency List	APPLICATION-INITIAL	2/9/2026
LEAF Capital Funding LLC	Lease Equipment	Common Business	PAID-INITIAL	7/8/2024
Lee Electrical Construction Inc	substation services, transmission, distribution, emergency restoration, directional boring, renewable energy	Georgetown All Proof Combined	APPLICATION-INITIAL	11/3/2025
LEE JEFFREY A	Parcel Data Owner	Parcel Data Owner	Needs Mail Sent	9/2/2025
Lee Transport Equipment, Inc.	Installation and service of transport equipment	City Vendor List	APPLICATION-INITIAL	2/11/2026
Leland O'neil Plumbing and Backflow Specialties	Plumbing services	Georgetown County School Transparency September-October 2024	MAIL SENT	11/22/2025
LensLock	Body worn cameras, in-car cameras, surveillance cameras, evidence management	City Vendor List	PAID-INITIAL	1/3/2025
LIBERTY STEEL GEORGETOWN INC	Parcel Data Owner	Parcel Data Owner	Needs Mail Sent	9/2/2025
LiftOne, LLC	Lease Equipment	Common Business	PAID-2ND RENEWAL	7/16/2025
Lincare	Home healthcare services	Discovery	PAID-RENEWAL	7/16/2025
Linde Gas & Equipment Inc.	Industrial gases, supply, equipment & services	Georgetown County School Transparency 02/2025	PAID-INITIAL	11/5/2025
Lindler's Construction of South Carolina, LLC	General Contractor	Discovery	APPLICATION-2ND FOLLOW UP	12/4/2025
Line Equipment Sales Company Inc	Test Lab, Tool Repair, Manufacturing, Delivery via own company fleet	City Vendor List	PAID-RENEWAL	7/16/2025
LINEN ONEAL	Parcel Data Owner	Parcel Data Owner	Needs Mail Sent	9/2/2025
Live Productions	Lighting, sound, staging, entertainment, planning/management/design, equipment rentals, power management	Georgetown County School Transparency List	APPLICATION-INITIAL	2/9/2026
LKP LLC CWBJR LLC	Parcel Data Owner	Parcel Data Owner	Needs Mail Sent	9/2/2025
LONG SHOT LLC	Parcel Data Owner	Parcel Data Owner	Needs Mail Sent	9/2/2025
Loomis Armored US LLC	Armored truck services	Common Business	PAID-2ND RENEWAL	7/16/2025
Lowco Roofing	Roofing Services, Interior & Exterior Painting	Google Maps Data SC (Inside City Limits)	APPLICATION-2ND FOLLOW UP	12/6/2025
Lowcountry Sod Pros	Sodding, hardscapes, patios, paving	Georgetown County Vendor List	APPLICATION-INITIAL	2/11/2026
LPL Solar LLC		City Vendor List 08-2025	APPLICATION-INITIAL	3/9/2026
Lumio HX Inc dba Zeo Energy	Solar installation company	Client Referral	APPLICATION-INITIAL	10/24/2025
Lux Vending dba Bitcoin Depot	DNA - Bitcoin atm rentals	Common Business	PAID-2ND RENEWAL	7/16/2025
LWTT LLC	Parcel Data Owner	Parcel Data Owner	Needs Mail Sent	9/2/2025
MADISON TRUST CO FBO SHELTON ROBERT E III	Parcel Data Owner	Parcel Data Owner	Needs Mail Sent	9/2/2025
MAGCHASE LLC	Parcel Data Owner	Parcel Data Owner	Addr Complete/Pending apps	10/31/2025
MAGNOLIA COMMONS LLC	Parcel Data Owner	Parcel Data Owner	Needs Mail Sent	9/2/2025
Mansfield Oil Company	Supplies-Maintenance, fuel system design build, environmental compliance testing and reporting, fuel quality management, gas delivery and mobile fueling	City Vendor List 2021 & 2024 - Georgetown County School Transparency 2021 & 2023-2024 - Georgetown County AP 2023	ONE AT A TIME	2/25/2026

MARY GEORGE PROPERTIES LLC	Parcel Data Owner	Parcel Data Owner	Needs Mail Sent	9/2/2025
Masimo Americas Inc.	Medical monitoring machines	City Vendor List	APPLICATION-INITIAL	2/9/2026
MATHES PH INVESTMENT LLC	Parcel Data Owner	Parcel Data Owner	PAID-INITIAL	1/1/2026
MCCLARY JESSIE S III	Parcel Data Owner	Parcel Data Owner	Needs Mail Sent	9/2/2025
MCLAUGHLIN RHONDA	Parcel Data Owner	Parcel Data Owner	Addr Complete/Pending apps	12/15/2025
Meco Inc of Florence	Petroleum refueling, technicians come on site for maintenance/repairs, have own company fleet of vehicles	City Vendor List	PAID-2ND RENEWAL	7/16/2025
Mega LED Technology (Mega Sign Inc)	Large sign manufacturing and install	City Vendor List	Needs Mail Sent	2/13/2026
MICHELLE AND CHARLES SMITH	Commercial Property Owner	ParcelData2025 - Inside City	MAIL SENT	9/4/2025
Mighty Tiny Marketing	personalized marketing, social media, and business plan to increase leads, sales, and brand awareness.	Client Referral	NEW ACCOUNT LOAD	10/6/2025
MILLER DAISY LEE TRUSTEE MILLER DAISY LEE	Parcel Data Owner	Parcel Data Owner	Needs Mail Sent	9/2/2025
MILLER JOHN A MILLER KRISTI D	Parcel Data Owner	Parcel Data Owner	Needs Mail Sent	9/2/2025
MINGO PROPERTIES LLC	Commercial Property Owner	ParcelData2025 - Inside City	MAIL SENT	9/4/2025
MINGO PROPERTIES LLCC	Parcel Data Owner	Parcel Data Owner	Needs Mail Sent	9/2/2025
Mohawk Lifts LLC (Mohawk Resources Ltd)	Hydraulic lifts, forktruck lifts, automotive lifts, parts and services	City Vendor List 09-2025	APPLICATION-INITIAL	2/9/2026
MONEYLINE PROPERTIES LLC	Commercial Property Owner	ParcelData2025 - Inside City	MAIL SENT	9/4/2025
Moore Athletic's LLC-Aaron Moore	Athletic services	Client Referral	NEW ACCOUNT LOAD	10/6/2025
MOORE JAMES B JR	Parcel Data Owner	Parcel Data Owner	Addr Complete/Pending apps	11/18/2025
Moseley Inc	Architects	Georgetown County AP 2023	PAID-INITIAL	12/3/2025
Motorola Solutions Inc	Access control systems, video security, body worn cameras, cybersecurity services, on-site preventative maintenance, technology lifecycle management	Common Business	PAID-2ND RENEWAL	7/16/2025
MSA Safety Sales LLC	Safety equipment supplier, on-site service and equipment repair, rental equipment	Common Business	PAID-INITIAL	12/11/2024
Multiquip Inc	quality industrial products and innovative solutions, field service techs	City Vendor List 09-2025	APPLICATION-INITIAL	2/9/2026
Municipal Emergency Services (MES Fire)	Fire Fighter Equipment, on Site Service and Repair with own company fleet	Client Referral	NEW ACCOUNT LOAD	10/6/2025
Nalco Company LLC	Water treatment	Georgetown County Business Personal Property Tax	PAID-2ND RENEWAL	7/16/2025
National Power Corporation	Generator Repair and Rental	Common Business	PAID-RENEWAL	7/16/2025
NearPod Inc	Interactive mobile presentations that teachers create and customize themselves-In person training	Georgetown County School Transparency 02/2025	Needs Mail Sent	11/7/2025
NELSON FAMILY LIMITED PART NELSON HARRIET G	Parcel Data Owner	Parcel Data Owner	Addr Complete/Pending apps	11/18/2025
NetSource ET, LLC	Educational Technology	Georgetown County School Transparency List	Needs Mail Sent	12/15/2025
New Dairy Group, LLC. (DBA Borden Dairy) *SC*	Retail product sold and delivered via own trucks	Georgetown Combined Muni Lists	Multiple Attempts	10/7/2025
NEWPORT LAND PARTNERS LLC	Parcel Data Owner	Parcel Data Owner	Needs Mail Sent	9/2/2025
NEWTOWNE PROPERTIES OF SC INC	Parcel Data Owner	Parcel Data Owner	Needs Mail Sent	9/2/2025
NORTHGATE OF GEORGETOWN LLC	Parcel Data Owner	Parcel Data Owner	Needs Mail Sent	9/2/2025
NS RETAIL HOLDINGS LLC	Parcel Data Owner	Parcel Data Owner	Addr Complete/Pending apps	2/20/2026
Nu-Idea School Supply Co.	Furniture supplier	Georgetown County School Transparency List	PAID-2ND RENEWAL	7/16/2025
OAK RIDGE SOUTH LLC	Parcel Data Owner	Parcel Data Owner	Needs Mail Sent	9/2/2025
Olympus America Inc	Equipment rental	Common Business	PAID-INITIAL	4/4/2023
ON FRONT LLC	Parcel Data Owner	Parcel Data Owner	Needs Mail Sent	9/2/2025

Osmose Utility Services Inc	Wood pole inspection, remedial treatment, and restoration. Steel asset life protection, deterioration assessment, identification of structures in need of repair and mitigation. Contact voltage, overhead, analytics. Storm support and joint use	City Vendor List 10-2025	APPLICATION-INITIAL	12/31/2025
OTC Industrial Technologies DBA PSI Services Inc	Compressor systems, finishing and dispensing and filtration solutions, pump systems, rental solutions, service and repair	Georgetown All Proof Combined	Verifying Liability	12/15/2025
OVERTON FAMILY PARTNERSHIP LLC	Parcel Data Owner	Parcel Data Owner	Needs Mail Sent	9/2/2025
OWENS JAMES B	Parcel Data Owner	Parcel Data Owner	Needs Mail Sent	9/2/2025
Palmetto Fire Services LLC	commercial fire alarms, nurse call systems, mass notifications, fire system testing on site	Georgetown All Proof Combined	APPLICATION-INITIAL	12/8/2025
PALMETTO PROPERTIES OF G-TOWN LLC	Parcel Data Owner	Parcel Data Owner	CALCULATION SENT	12/22/2025
PARKER HOLDINGS OF HANAHAN LLC	Parcel Data Owner	Parcel Data Owner	Needs Mail Sent	9/2/2025
PARSONS QUINCY ROBERT	Parcel Data Owner	Parcel Data Owner	Needs Mail Sent	9/2/2025
PATJA LLC	Parcel Data Owner	Parcel Data Owner	Needs Mail Sent	9/2/2025
Pawleys Island Locksmith	Locksmith services	City Vendor List	PAID-2ND RENEWAL	7/16/2025
Pawnee Leasing Corporation	Lease equipment	Common Business	PAID-RENEWAL	7/16/2025
Pee Dee Scale Company	Scale supplier, have own company fleet of trucks	Georgetown County Vendor List	MAIL SENT	11/22/2025
PENDULUM PROPERTIES LLC	Parcel Data Owner	Parcel Data Owner	Needs Mail Sent	9/2/2025
Pet Dairy	Dairy Products	Georgetown County Schools Transparency Jan-April 2023	Needs Mail Sent	2/13/2026
Pike Gas Services	Natural gas infrastructure services	Client Referral	NEW ACCOUNT LOAD	10/6/2025
Pinnacle Network Solutions	Consulting, onsite repair, warranty services	Georgetown County School Transparency 2021 & 2023-2024	Needs Mail Sent	11/20/2025
PJH LLC	Parcel Data Owner	Parcel Data Owner	Addr Complete/Pending apps	11/18/2025
Playground Guardian	Playground Maintenance and Repairs	City Vendor List 10-2025	APPLICATION-INITIAL	12/31/2025
Playworld Preferred, Inc	Playground equipment supplier	Georgetown County School Transparency 02/2025	PAID-INITIAL	5/13/2025
PlumbMaster Inc	Technical/special services, inventory consultation, field sales reps	Discovery	WAITING ON PROOF RESPONSE-(disc	11/20/2025
PNRE HOLDINGS LLC	Parcel Data Owner	Parcel Data Owner	Needs Mail Sent	11/5/2025
Porter Roofing Contractors Inc	Roofing contractor	Georgetown County School Transparency 2021 & 2023	Needs Mail Sent	2/12/2026
PRIOLEAU HENRY P HRS	Parcel Data Owner	Parcel Data Owner	Needs Mail Sent	9/2/2025
Pro Chem, INC	Chemical products	City Vendor List 10-2025	APPLICATION-1ST FOLLOW UP	2/9/2026
ProPump & Controls Inc	Pump station install and maintenance, irrigation control panels and retrofits, wet well install, biogas systems, pipe fitting and fabrication. Sales reps	City Vendor List	APPLICATION-INITIAL	2/11/2026
Protective Technologies Inc	Cathodic protection, tank lining, internal inspections, under-dispenser containment, sump repairs, sump waterproofing, spill bucket repairs	Discovery	WAITING ON PROOF RESPONSE-(disc	1/6/2026
Pro-Tek Termite and Pest Control	Pest control services	Georgetown County Vendor List	MAIL SENT	11/22/2025
PROVIDENT TRUST GROUP LLC ETAL CRANBERRY REALTY TRUST	Parcel Data Owner	Parcel Data Owner	Needs Mail Sent	9/2/2025
Pugh Lubricants, LLC dba Apollo Oil, LLC	Distributor of automotive-fleet oils and greases, oil and fuel absorbents, and car oil,fuel, air filters	Common Business	PAID-2ND RENEWAL	7/16/2025
PURAH LLC	Parcel Data Owner	Parcel Data Owner	CLOSED-NO ACTIVITY	12/16/2025
PVS Chemicals	Chemical manufacturing and delivery services	Georgetown County Vendor List	MAIL SENT	11/22/2025
PYATT MATTHEW HRS	Parcel Data Owner	Parcel Data Owner	Needs Mail Sent	9/2/2025
Quadient, Inc. (previously Neopost USA, Inc.)	rental of postage meter and supplies	Georgetown County School Transparency 2023-2024	Multiple Attempts	11/21/2025
Quantum Health Professionals, Inc	Staffing service	Georgetown County School Transparency 2023-2024	PAID-INITIAL	5/28/2025

Quench USA Inc (Advanced H2O Solutions LLC)	Water technology company that rents and services filtered water coolers.	Common Business	PAID-RENEWAL	7/16/2025
Quest Resource Management Group	Recycling & Disposal Services and equipment rentals	Common Business	PAID-2ND RENEWAL	7/16/2025
R H PROPERTIES LLC OF GEORGETOWN	Parcel Data Owner	Parcel Data Owner	Needs Mail Sent	9/2/2025
R.C. Jacobs, Inc (RC Jacobs Plumbing, heating, and A/C Inc)	Heating or Cooling Repair Service (HVAC services)	City Vendor List 08/2025	APPLICATION-INITIAL	3/9/2026
REARDON DEBBY	Parcel Data Owner	Parcel Data Owner	PAID-INITIAL	1/1/2026
REID BRODERICK M REID ROCHELLE G	Parcel Data Owner	Parcel Data Owner	Needs Mail Sent	9/2/2025
Rentokil North America Inc dba J C Ehrlich Co, Inc	Pest control & consulting	Common Business	PAID-2ND RENEWAL	7/16/2025
RESTORE REALTY LLC	Commercial Property Owner	ParcelData2025 - Inside City	PAID-INITIAL	9/15/2025
Revels Turf & Tractor	Sports turf equipment distributor- new & used turf equipment, leasing, repairs/service	City Vendor List 09-2025	APPLICATION-INITIAL	2/9/2026
RICHMOND REALTY CO LLC	Parcel Data Owner	Parcel Data Owner	Needs Mail Sent	9/2/2025
RICHMOND REALTY COMPANY LLC	Commercial Property Owner	ParcelData2025 - Inside City	MAIL SENT	9/4/2025
RIONS LION DEN LLC	Parcel Data Owner	Parcel Data Owner	Needs Mail Sent	9/2/2025
RITA JAMES LLC	Parcel Data Owner	Parcel Data Owner	Needs Mail Sent	9/2/2025
RoadSafe Traffic Systems	Traffic Control, Pavement Marking and Removal, Sign Installation, Daily Rental	City Vendor List 10-2025	NEW ACCOUNT LOAD	12/9/2025
Robert Half International Inc	Accounting Staffing Agency	Common Business	PAID-2ND RENEWAL	7/16/2025
ROBINSON WILLIE LOUISE CO-TRUSTEE BURNS JANICE R CO-TRUSTEE	Parcel Data Owner	Parcel Data Owner	Needs Mail Sent	9/2/2025
Rowe Professional Services Company	Engineering, architectural, surveying	Georgetown All Proof Combined	APPLICATION-INITIAL	12/8/2025
Royal Cup Inc	sale of coffee and tea	Common Business	PAID-2ND RENEWAL	7/16/2025
RRJG FRASER ST LLC	Parcel Data Owner	Parcel Data Owner	Needs Mail Sent	9/2/2025
Rug Doctor LLC	Rental cleaning supplies	Common Business	PAID-2ND RENEWAL	7/16/2025
RUSSELL REAL ESTATE INVESTMENTS LLC	Parcel Data Owner	Parcel Data Owner	Addr Complete/Pending apps	11/3/2025
S&R Turf and Irrigation Equipment, LLC	Irrigation Equipment, Parts and Service, sod sales, golf course services	Georgetown County Vendor List	Addr Complete/Pending apps	9/19/2025
SACORONTZES PROPERTIES LLC	Parcel Data Owner	Parcel Data Owner	Addr Complete/Pending apps	11/18/2025
Safeware Inc	Safety equipment rentals and sales, on-site technical services. Have own company fleet of vehicles	City Vendor List	APPLICATION-INITIAL	2/18/2026
SAMPIT RIVER PROPERTIES LLC	Parcel Data Owner	Parcel Data Owner	Needs Mail Sent	9/2/2025
SANITARY AND SANITARY L.L.C.	Parcel Data Owner	Parcel Data Owner	Needs Mail Sent	9/2/2025
Santee Automotive Ford Dealership	Car dealership w/ delivery & roadside assistance	Georgetown County Schools Transparencies Jan-April 2023	Verifying Liability	11/4/2025
SAWYER SCOTT C	Parcel Data Owner	Parcel Data Owner	Needs Mail Sent	9/2/2025
SBK SC PORTFOLIO OWNER LLC	Parcel Data Owner	Parcel Data Owner	Needs Mail Sent	9/2/2025
School Bell Studio	Photography for schools, yearbooks, ids, photos, dances, etc	Georgetown County Schools Transparencies Jan-April 2023	PHONE CALL	2/13/2026
SEAPORT OIL CO INC	Parcel Data Owner	Parcel Data Owner	Needs Mail Sent	9/2/2025
Security Solutions of America	Guarding, event security, mobile patrol, remote guarding, perimeter security, client specialized training	Georgetown County Vendor List	2nd Phone Call	11/4/2025
SevenE LLC	Parcel Data Owner	Parcel Data Owner	Addr Complete/Pending apps	11/7/2025
SEYMOUR WILLIAM F SHAWN ALAN COPELAND TSTEE	Parcel Data Owner	Parcel Data Owner	Needs Mail Sent	9/2/2025
SHE KNOWS PROPERTIES LLC	Commercial Property Owner	ParcelData2025 - Inside City	Addr Complete/Pending apps	9/10/2025
SHEEHAN LARRY E C/O MINGO PROPERTIES LLC	Parcel Data Owner	Parcel Data Owner	Needs Mail Sent	9/2/2025
SHELTON CHARLES A SHELTON JANICE M	Parcel Data Owner	Parcel Data Owner	Addr Complete/Pending apps	11/18/2025

SHI International Corp	Reseller of software, hardware, and related servicetechnology products and services	Georgetown County School Transparency October 2024	Multiple Attempts	7/21/2025
SHIV SHAKTI PROPERTY LLC	Commercial Property Owner	ParcelData2025 - Inside City	PAID-INITIAL	2/27/2026
Shutterfly Lifetouch, LLC (Previously Lifetouch National School Studios Inc)	Pictures taken at school locations	Common Business	PAID-RENEWAL	7/16/2025
SIMMONS JAMES	Parcel Data Owner	Parcel Data Owner	Needs Mail Sent	9/2/2025
SIMMONS JAMISON	Parcel Data Owner	Parcel Data Owner	Needs Mail Sent	9/2/2025
Sirchie FingerPrint Labs	Crime Scenes Investigation & Forensic Science Solutions and training	City Vendor List	MAIL SENT	11/22/2025
SMITH HERBERT	Parcel Data Owner	Parcel Data Owner	Needs Mail Sent	9/2/2025
SMITH MICHELLE LYNN SMITH CHARLES RICHARD JR	Parcel Data Owner	Parcel Data Owner	Needs Mail Sent	9/2/2025
Smith's Addressing Machine Services	Installation, onsite service, and preventive maintenance-	Georgetown County School Transparency List	AUDIT IN PROCESS	2/5/2026
Snider Tire Inc dba Snider Fleet Solutions	Roadside service with mobile service trucks, tire retread, fleet management, onsite scheduled services, forklift repairs. Have own company fleet of vehicles	Common Business	PAID-2ND RENEWAL	7/16/2025
SOUTH IMPROVEMENT COMPANY LLC THE	Commercial Property Owner	ParcelData2025 - Inside City	PAID-INITIAL	9/30/2025
SOUTH ISLAND LIVING LLC	Parcel Data Owner	Parcel Data Owner	Needs Mail Sent	9/2/2025
Southeastern Paper Group	Distributor of disposables, packaging, janitorial/sanitation supplies and equipment	City Vendor List	APPLICATION-INITIAL	2/3/2026
Sparrow and Kennedy Tractor Company	Tractor and outdoor equipment supplies, repair technicians with own company fleet of vehicles	City Vendor List	APPLICATION-INITIAL	2/5/2026
SPATCO Energy Solutions	Equipment installation & repairs	Common Business	PAID-2ND RENEWAL	7/16/2025
Stantec Consulting Services	Consulting services	Georgetown County Vendor List	PAID-INITIAL	7/11/2025
STERN FIRST LLC	Commercial Property Owner	ParcelData2025 - Inside City	PAID-INITIAL	9/17/2025
Stone Construction Company	Excavation Contractor, septic services	City Vendor List	PAID-INITIAL	6/4/2024
Stryker Sales LLC (dba Stryker Medical)	Medical devices and equipment	Common Business	PAID-2ND RENEWAL	7/16/2025
Sumter Utilities	Construction	City Vendor List 8/2024	Multiple Attempts	10/7/2025
Sunbelt Soloman Services LLC	Industrial transformer sales, services, and rent	Georgetown County Vendor List	MAIL SENT	12/4/2025
Superior Plus Energy Services dba Freeman Gas	Propane Supplier- delivery, install/repair	Business Self Reported	PAID-2ND RENEWAL	7/16/2025
TAFT SONYA BLAIR	Parcel Data Owner	Parcel Data Owner	Needs Mail Sent	9/2/2025
Talotta Contract Interiors	Moving and delivery services, project management, installations, interior designers, space planning. Have own company fleet of vehicles	City Vendor List	PAID-INITIAL	9/30/2024
TAYLOR CHRISTOPHER GEORGE	Parcel Data Owner	Parcel Data Owner	Needs Mail Sent	9/2/2025
TBABIT LLC	Parcel Data Owner	Parcel Data Owner	Needs Mail Sent	9/2/2025
TENNANT MARGOT	Parcel Data Owner	Parcel Data Owner	Needs Mail Sent	9/2/2025
TERESA IRENE BLACK	Commercial Property Owner	ParcelData2025 - Inside City	MAIL SENT	9/4/2025
The Wagner Consulting Group, Inc.	Consulting and inspections	Client Referral	NEW ACCOUNT LOAD	10/6/2025
Therapy Travelers LLC	Staffing agency for school districts, clinicians, and educators	Business request	PAID-RENEWAL	9/30/2024
Thermal Technologies Inc	Commercial ripening room design and construction	City Vendor List 09-2025	APPLICATION-INITIAL	2/9/2026
THERMATECH SERVICES LLC	Parcel Data Owner	Parcel Data Owner	Needs Mail Sent	9/2/2025
Thomas and Hutton	Engineering services	City Vendor List 10-2025	APPLICATION-INITIAL	12/31/2025
THOMAS PROPERTY MANAGEMENT LLC	Parcel Data Owner	Parcel Data Owner	Needs Mail Sent	9/2/2025
Thompson Turner Construction	Construction company	Discovery	Multiple Attempts	3/3/2026
TIAA Commercial Finance, Inc	DNA - Commercial equipment leasing	Common Business	PAID-INITIAL	11/30/2022
TIAA FSB	Commercial Equipment Leasing (Separate Entity from TIAA Commercial Finance)	discovery	PAID-INITIAL	11/30/2022
TICE DEBORAH F TICE MARK A	Parcel Data Owner	Parcel Data Owner	Verifying Liability	12/12/2025

Timepayment Corporation	Lease Equipment	Common Business	PAID-INITIAL	7/16/2025
Tisdale Plumbing Company	Plumbing services	Georgetown County School Transparency List	APPLICATION-INITIAL	2/5/2026
TMT HOLDINGS LLC	Parcel Data Owner	Parcel Data Owner	Needs Mail Sent	9/2/2025
TOOTH WIZARD LLC	Parcel Data Owner	Parcel Data Owner	Needs Mail Sent	11/5/2025
Toter LLC	Cart assembly and delivery, cart maintenance, RFID cart management, custom solutions. Have own company fleet of vehicles	Georgetown County Vendor List	MAIL SENT	11/22/2025
Toyota Industries Commercial Finance INC	Forklifts Financial Services	Common Business	PAID-RENEWAL	7/16/2025
TRAN HAI D NGUYEN HOAI T	Parcel Data Owner	Parcel Data Owner	Needs Mail Sent	9/2/2025
Trane US Inc	Maintenance Repairs	Georgetown County School Transparency List	PAID-2ND RENEWAL	7/16/2025
TRINITY INVESTMENTS OF THE PIEDMONT LLC	Parcel Data Owner	Parcel Data Owner	PAID-INITIAL	1/1/2026
TruckPro LLC	Truck parts and service experts	Common Business	PAID-RENEWAL	7/16/2025
TUPACZ PROPERTIES LLC	Parcel Data Owner	Parcel Data Owner	CALCULATION SENT	1/23/2026
US Foods, Inc.	Food supplier (retail)	Georgetown County School Transparency List & City Vendor List	PAID-2ND RENEWAL	7/16/2025
US Tire Recycling LP	Tire recycling, Tire remediation (on-site tire collection)	Georgetown County Vendor List	PAID-INITIAL	12/20/2024
USIC Locating Services, LLC	Locating Underground Services	Business Provided	PAID-INITIAL	5/1/2025
ViaSat, Inc.	Lease and install internet equipment	Common Business	PAID-2ND RENEWAL	7/16/2025
VL Contractors	Floor services, ceramic tile services, kitchen renovation	Client Referral	NEW ACCOUNT LOAD	10/6/2025
W.W. Grainger, Inc	Cleaning and Sanitation	Common Business	PAID-2ND RENEWAL	7/16/2025
W.W. Williams Company, LLC	Vehicle Parts/Service/Repair	Common Business	PAID-2ND RENEWAL	7/16/2025
WALKER CATHERINE	Parcel Data Owner	Parcel Data Owner	Needs Mail Sent	9/2/2025
Ward Diesel Filter Systems	Manufacturing and installation of exhaust filtration solutions	City Vendor List 10-2025	APPLICATION-INITIAL	12/31/2025
Watford's Wrecker Service Inc	Wrecker services, towing	Georgetown All Proof Combined	APPLICATION-INITIAL	12/8/2025
WATKINS JOHN M	Parcel Data Owner	Parcel Data Owner	Needs Mail Sent	9/2/2025
Wells Fargo Vendor Financial Services	Equipment leasing	Common Business	PAID-2ND RENEWAL	7/16/2025
WENDY BONDS-JANOWSKI	Commercial Property Owner	ParcelData2025 - Inside City	MAIL SENT	9/4/2025
Wesco Distribution Inc dba Englewood Electrical Supply Company	Automation Solutions, Managed Solutions, Training Solutions, Inventory Management and Consolidation, Lighting Services, Ecommerce	City Vendor List	PAID-RENEWAL	7/16/2025
WHLR-GEORGETOWN LLC	Parcel Data Owner	Client Referral and Parcel Data	APPLICATION-INITIAL	10/16/2025
WILLIAMS LILLIE R WILLIAMS JASON C	Parcel Data Owner	Parcel Data Owner	Needs Mail Sent	9/2/2025
Williams Scotsman, Inc. (dba WillScot dba Mobile Mini)	Builds/leases modular buildings, portable classrooms, and mobile office space	Common Business	PAID-2ND RENEWAL	7/16/2025
WINN HOLDINGS LLC	Parcel Data Owner	Parcel Data Owner	Needs Mail Sent	9/2/2025
WINYAH 515 LLC	Commercial Property Owner	ParcelData2025 - Inside City	MAIL SENT	9/4/2025
WINYAH INVESTORS	Parcel Data Owner	Parcel Data Owner	Needs Mail Sent	9/2/2025
WINYAH INVESTORS C/O NEWTOWNE PROPERTIES	Commercial Property Owner	ParcelData2025 - Inside City	MAIL SENT	9/4/2025
WINYAH PROPERTIES LLC	Parcel Data Owner	Parcel Data Owner	PAID-INITIAL	1/1/2026
WK Dickson & Co	Infrastructure Consultant/General Contractor	Georgetown County AP 2023 & City Vendor List 2021-2022 & 2024	Multiple Attempts	10/3/2025
WM Building Envelope Consultants LLC	Exterior Walls, Roofing and Waterproofing consulting services	Georgetown County School Transparency List	APPLICATION-INITIAL	2/11/2026
Wyeth Holdings, LLC (Pfizer Inc)	Medical Equipment sales and rental	Common Business	PAID-RENEWAL	7/16/2025
Xerox Corporation	Lease Equipment		PAID-2ND RENEWAL	7/16/2025
YELLOW TAG II LLC	Commercial Property Owner	ParcelData2025 - Inside City	MAIL SENT	9/4/2025
ZAJAH VENTURES LLC	Commercial Property Owner	ParcelData2025 - Inside City	MAIL SENT	9/4/2025

Zimmer US, Inc.	Lease Equipment - sales and marketing of orthopedic, sports medicine, surgical and trauma products	Common Business	PAID-2ND RENEWAL	7/16/2025
-----------------	--	-----------------	------------------	-----------

The **FIRE** Report

A monthly report of Fire Department activities to City Council

March
2026



Fire Prevention Bureau

2026

February

Inspections	100
Violations Found	122
Buildings without Violations	35
Buildings Cleared of Violations	11
Violations Corrected	11
Violations Not Corrected	111
3rd Party Inspection Review	25
Assemblies Inspected:	15
Business Inspected:	47
Educational Buildings Inspected:	4
Factories Inspected:	2
Mobile Food Trucks	0
Hazardous Buildings Inspected	0
Institutional Inspected:	0
Mercantile Inspected:	23
Residential Inspected:	6
Storage Buildings Inspected:	3
Construction Meetings:	0
Plans Review:	1
Test Conducted:	0
Compliance Issues:	0
Complaints Reviewed:	0
Business License:	3
Citation Issued:	0

Public Education

Programs	1
Participants	9

Suppression Division

A Brief Look at Emergency Responses

February 2026

1. Fourteen Medical Calls; Five Public Service Calls
2. Eleven Medical Calls; One False Call; One Public Service Call
3. Nine Medical Calls; Two Electrical Shorts; One Alarm Activation; One MVA
4. Thirteen Medical Calls; Two MVA's
5. Four Medical Calls; One Accidental Alarm Activation
6. Four Medical Calls; One Watercraft In Distress Call
7. Twelve Medical Calls
8. Nine Medical Calls; One False Alarm; One MVA; One Public Service Call
9. Eleven Medical Calls; Two MVA's; Three Public Service Calls
10. Six Medical Calls; One Public Service Call
11. Six Medical Calls; One Cooking Fire; One Public Service
12. Seven Medical Calls; One False Alarm; One Public Service Call
13. Seven Medical Calls; One Alarm Activation; Two Public Service Calls
14. Six Medical Calls; One Contents Fire; Three Public Service Calls
15. Five Medical Calls
16. Five Medical Calls; One electrical Short; One Smoke Investigation; Two Public Service Calls
17. Five Medical Calls; Three MVA's; Two Public Service Calls
18. Nine Medical Calls; One Smoke Investigation
19. Six Medical Calls; One Trash Fire; One Mutual Aid Call
20. Nine Medical Calls; One Public Service Call
21. Three Medical Calls; Two Public Service Calls
22. Six Medical Calls
23. One Medical Call; Three Public Service Calls
24. Five Medical Calls; One Bomb Threat; Two Outside Fires; One Cooking Fire; One MVA; One Public Service Call
25. Four Medical Calls; Two Public Service Calls
26. Five Medical Calls; One MVA; One False Alarm
27. Six Medical Calls; One MVA
28. Eleven Medical Calls; Two False Alarms; Two Public Service Call



Save/Loss Analysis

	Losses	Property Values
February 2026	\$ 500	\$ 50,000
February 2025	\$ 171,700	\$ 674,800
Year to Date	\$ 470,557	\$ 5,738,775

Property values are estimates based on the Georgetown County Assessor's Office 2020 Market Values.

Mutual Aid Calls

	February	YTD
To Georgetown County Fire	0	7
To Midway Fire	7	44
To other Departments	0	0
From Georgetown County Fire	0	3
From Midway	4	29
From other Departments	0	0

	February	YTD
<u>Staff Training Hours</u>	1672	12238.50

FLEET SERVICES MONTHLY REPORT (FY 24-25)

Task	Jul-25	Aug-25	Sep-25	Oct-25	Nov-25	Dec-25	Jan-26	Feb-26
Repairs	77	76	65	58	60	35	70	57
Preventative Maintenance	18	21	17	16	11	26	27	22
Tires repaired or Replaced	35	30	33	38	22	30	46	20
Services Past Due	-	-						
Monthly Totals	130	127	115	112	93	91	143	99

Mar-26	Apr-26	May-26	Jun-26	Cummulative
				498
				158
				254
				-
-	-	-	-	910

Task

Repairs

Preventative Maintenance

MAYOR
JAY DOYLE

CITY ADMINISTRATOR
SCOTT WHITTIER

CITY CLERK
STEPHANIE BUCCIONE



COUNCIL MEMBERS
VACANT
MAYOR PRO TEMPORE

BRUCE CARL
ERIN ETHRIDGE
SHARON MELTON
HOBSON H. MILTON
JESSIE WALKER
TAMIKA WILLIAMS-OBENG

Administration
Human Resources
Katie Badgett/HR Director
Office: (843) 545.4004

Human Resources Department February 2026 Report

New Hires:

Department	Employee Name	Position
Fire Dept.:	Kyle Lindsay	Part-time Firefighter/EMT
Finance Dept.	Allison Lindy	CSR
Planning Dept.	Jennifer Boyer	Director
Police Dept.	Randall Childers	PO I
	Nolan Small	PO I
Public Works	William Salter	Grounds Maintenance Tech

Separations: None

Department	Employee Name	Position
Fire Dept.	Dakota Chandler	Firefighter
	Alexander Roman	Firefighter

Promotions: None

Department	Employee Name	Position
Police Dept.	Bailey Trahey	PO III

Positions Open:

Open Until Filled Positions:

Department	Job Title	Date Position Opened
Fire Dept.	Firefighter EMT	July 15, 2025
Water Dept.	WW Collection System Oper.	January 14, 2026
	Facilities Maintenance Tech I & II	January 14, 2026
Public Works	Grounds Maintenance Tech.	January 14, 2026
Electric Dept.	Ground Worker (Line Tech)	Feb. 3, 2026
	Electric Line Tech "A"	Feb. 3, 2026

Municipal Court Monthly Report (Fiscal Year 2023)

Cases Disposed	July		August		September		October		November		December	
	# of Cases Disposed	Fine Amounts	# of Cases Disposed	Fine Amounts	# of Cases Disposed	Fine Amounts	# of Cases Disposed	Fine Amounts	# of Cases Disposed	Fine Amounts	# of Cases Disposed	Fine Amounts
Paid	21	\$ 4,433.00	20	\$ 3,795.00	28	\$ 5,855.00	38	\$ 7,164.00	39	\$ 6,503.23	62	\$ 10,667.75
Served Time	8	\$ 9,530.00	12	\$ 14,877.50	7	\$ 8,235.00	8	\$ 10,957.50	14	\$ 23,317.50	16	\$ 12,882.50
Scheduled Time Payment	13	\$ 4,011.89	24	\$ 11,809.78	15	\$ 4,839.52	16	\$ 7,507.32	8	\$ 4,947.47	13	\$ 4,481.38
NRVC	5	\$ 1,577.50	13	\$ 3,870.00	9	\$ 2,257.50	9	\$ 3,452.00	19	\$ 7,454.00	19	\$ 3,977.50
Tried in Absence	24	\$ 13,967.50	9	\$ 5,153.34	20	\$ 11,333.50	9	\$ 7,270.00	8	\$ 10,535.00	5	\$ 4,360.00
Parking Tickets Paid	34	\$ 460.00	43	\$ 1,255.00	14	\$ 245.00	22	\$ 340.00	37	\$ 540.00	43	\$ 825.00
Nolle Prosequi/Dismissed/Not Guilty	27		53		43		45		41		80	
Transferred to General Sessions Court	18		25		31		35		21		41	
Voided	10		3		5		3		5		5	
Fine Suspended	1	\$ 1,087.50							1	\$ 1,087.50		
Total	161	\$ 35,067.39	202	\$ 40,760.62	172	\$ 32,765.52	185	\$ 36,690.82	193	\$ 54,384.70	284	\$ 37,194.13

Cases Disposed	January		February		March		April		May		June	
	# of Cases Disposed	Fine Amounts	# of Cases Disposed	Fine Amounts	# of Cases Disposed	Fine Amounts	# of Cases Disposed	Fine Amounts	# of Cases Disposed	Fine Amounts	# of Cases Disposed	Fine Amounts
Paid	91	\$ 17,404.00	53	\$ 8,121.50	76	\$ 14,641.50	72	\$ 11,603.50	60	\$ 13,053.25	66	\$ 12,175.56
Served Time	7	\$ 5,435.00	13	\$ 8,302.50	3	\$ 3,445.00	7	\$ 7,347.50	11	\$ 8,127.50	9	\$ 8,932.50
Scheduled Time Payment	21	\$ 8,192.87	15	\$ 6,990.98	16	\$ 11,086.20	31	\$ 12,030.05	12	\$ 3,619.01	18	\$ 8,386.36
NRVC	22	\$ 4,538.75	5	\$ 617.00	25	\$ 6,819.00	36	\$ 12,634.75	9	\$ 1,760.00	20	\$ 5,291.50
Tried in Absence	12	\$ 9,916.25	16	\$ 7,395.50	24	\$ 13,640.00	23	\$ 15,766.50	3	\$ 1,050.00	11	\$ 8,185.00
Parking Tickets Paid	33	\$ 620.00	46	\$ 735.00	60	\$ 1,295.00	73	\$ 885.00	113	\$ 1,805.00	107	\$ 2,985.00
Nolle Prosequi/Dismissed/Not Guilty	110		64		114		109		59		73	
Transferred to General Sessions Court	14		25		31		23		24		20	
Voided	5		5		14		11		18		18	
Fine Suspended			1	\$ 465.00								
Total	315	\$ 46,106.87	243	\$ 32,627.48	363	\$ 50,926.70	385	\$ 60,267.30	309	\$ 29,414.76	342	\$ 45,955.92

Cases Disposed	Cumulative Totals	
	# of Cases Disposed	Fine Amounts
Paid	626	\$ 115,417.29
Served Time	115	\$ 121,390.00
Scheduled Time Payment	202	\$ 87,902.83
NRVC	191	\$ 54,249.50
Tried in Absence	164	\$ 108,572.59
Parking Tickets Paid	625	\$ 11,990.00
Nolle Prosequi/Dismissed/Not Guilty	818	-
Transferred to General Sessions Court	308	-
Voided	102	-
Fine Suspended	3	\$ 2,640.00
Total	3154	\$ 502,162.21

Municipal Court Monthly Report (Fiscal Year 2024)

Cases Disposed	July		August		September		October		November		December	
	# of Cases Disposed	Fine Amounts	# of Cases Disposed	Fine Amounts	# of Cases Disposed	Fine Amounts	# of Cases Disposed	Fine Amounts	# of Cases Disposed	Fine Amounts	# of Cases Disposed	Fine Amounts
Paid	49	\$ 7,622.00	86	\$ 17,781.23	57	\$ 12,079.50	45	\$ 8,557.50	57	\$ 10,944.38	31	\$ 7,273.50
Served Time	0	\$ -	7	\$ 8,035.00	6	\$ 8,392.50	18	\$ 13,357.50	16	\$ 12,985.00	7	\$ 8,027.50
Scheduled Time Payment	5	\$ 2,295.88	9	\$ 2,888.56	21	\$ 11,418.58	16	\$ 5,968.18	20	\$ 13,078.75	17	\$ 9,024.52
NRVC	14	\$ 2,475.25	18	\$ 5,660.00	19	\$ 9,212.50	25	\$ 8,043.00	28	\$ 8,099.50	11	\$ 3,106.75
Tried in Absence	3	\$ 3,055.00	11	\$ 8,654.95	13	\$ 8,810.00	9	\$ 2,980.00	23	\$ 23,017.50	15	\$ 15,405.00
Parking Tickets Paid	70	\$ 2,320.00	64	\$ 2,345.00	42	\$ 780.00	45	\$ 1,500.00	28	\$ 760.00	31	\$ 925.00
Nolle Prosequi/Dismissed/Not Guilty	37		77		96		59		62		57	
Transferred to General Sessions Court	26		11		30		51		27		29	
Voided	18		9		8		8		8		4	
Fine Suspended			0		0		1	\$ 2,125.00	0		0	
Code Enforcement Tried in Absence			5	\$ 5,437.50	1	\$ 1,087.50	0		0		3	\$ 3,262.50
Code Enforcement Fine Suspended			1	\$ 1,087.50	0		1	\$ 1,087.50	0		0	
Code Enforcement Fine Paid			0	\$ -			0		0		0	
Code Enforce Scheduled Time Payment												
Code Enforcement Nolle Prosequi							8		12		0	
Total	222	\$ 17,768.13	298	\$ 51,889.74	293	\$ 51,780.58	286	\$ 43,618.68	281	\$ 68,885.13	205	\$ 47,024.77

Cases Disposed	January		February		March		April		May		June	
	# of Cases Disposed	Fine Amounts	# of Cases Disposed	Fine Amounts	# of Cases Disposed	Fine Amounts	# of Cases Disposed	Fine Amounts	# of Cases Disposed	Fine Amounts	# of Cases Disposed	Fine Amounts
Paid	98	\$ 19,116.21	106	\$ 21,221.00	99	\$ 18,962.00	128	\$ 23,487.38	61	\$ 11,410.06	162	\$ 28,098.63
Served Time	3	\$ 2,057.50	14	\$ 19,997.50	4	\$ 2,295.00	15	\$ 14,687.50	13	\$ 12,362.50	12	\$ 10,332.50
Scheduled Time Payment	11	\$ 4,120.02	8	\$ 6,023.57	19	\$ 11,544.66	12	\$ 3,652.00	17	\$ 5,947.54	20	\$ 9,739.83
NRVC	26	\$ 6,743.00	15	\$ 4,124.50	26	\$ 5,817.00	23	\$ 5,050.25	19	\$ 4,510.75	39	\$ 9,192.50
Tried in Absence	9	\$ 5,920.00	7	\$ 7,830.00	18	\$ 11,600.75	9	\$ 6,364.50	2	\$ 697.50	14	\$ 10,030.00
Parking Tickets Paid	70	\$ 1,025.00	32	\$ 825.00	33	\$ 875.00	81	\$ 2,865.00	47	\$ 1,350.00	64	\$ 2,150.00
Nolle Prosequi/Dismissed/Not Guilty	81		54		118		90		79		92	
Transferred to General Sessions Court	24		28		12		42		37		24	
Voided	11		7		8		5		4		5	
Fine Suspended			2	\$ 440.00	0		0		0		0	
Code Enforcement Tried in Absence			2	\$ 2,175.00	0		0		2	\$ 2,175.00	4	\$ 4,350.00
Code Enforcement Fine Suspended					0		0		0		0	
Code Enforcement Fine Paid					0		0		0		0	
Code Enforce Scheduled Time Payment							1	\$ 772.50	4		0	
Code Enforcement Nolle Prosequi	3				0		3				4	
Total	336	\$ 38,981.73	275	\$ 62,636.57	337	\$ 51,094.41	409	\$ 56,879.13	285	\$ 38,453.35	440	\$ 73,893.46

Cases Disposed	Cumulative Totals	
	# of Cases Disposed	Fine Amounts
Paid	979	\$ 186,553.39
Served Time	115	\$ 112,530.00
Scheduled Time Payment	175	\$ 85,702.09
NRVC	263	\$ 72,035.00
Tried in Absence	133	\$ 104,365.20
Parking Tickets Paid	607	\$ 17,720.00
Nolle Prosequi/Dismissed/Not Guilty	902	\$ -
Transferred to General Sessions Court	341	\$ -
Voided	95	\$ -
Fine Suspended	3	\$ 2,565.00
Code Enforcement Tried in Absence	17	\$ 18,487.50
Code Enforcement Fine Suspended	2	\$ 2,175.00
Code Enforcement Fine Paid	0	\$ -
Code Enforce Scheduled Time Payment	1	\$ 772.50
Code Enforcement Nolle Prosequi	30	\$ -
Total	3667	\$ 602,905.68

Municipal Court Monthly Report (Fiscal Year 2025)

Cases Disposed	July		August		September		October		November		December	
	# of Cases Disposed	Fine Amounts	# of Cases Disposed	Fine Amounts	# of Cases Disposed	Fine Amounts	# of Cases Disposed	Fine Amounts	# of Cases Disposed	Fine Amounts	# of Cases Disposed	Fine Amounts
Paid	64	\$ 12,875.88	175	\$ 31,171.46	79	\$ 14,508.52	114	\$ 27,616.70	61	\$ 10,692.14	97	\$ 20,501.75
Served Time	13	\$ 12,452.50	19	\$ 18,347.50	10	\$ 14,107.50	17	\$ 20,040.00	10	\$ 11,705.00	13	\$ 15,092.50
Scheduled Time Payment	7	\$ 3,453.08	16	\$ 7,207.06	15	\$ 9,011.17	18	\$ 5,790.27	24	\$ 11,588.01	22	\$ 6,441.34
NRVC	17	\$ 3,710.00	38	\$ 9,306.00	14	\$ 2,831.63	21	\$ 6,457.50	25	\$ 6,986.76	27	\$ 7,454.88
Tried in Absence	11	\$ 8,231.25	7	\$ 3,795.00	5	\$ 4,317.50	20	\$ 10,675.00	9	\$ 10,480.00	10	\$ 6,458.00
Parking Tickets Paid	98	\$ 3,850.00	97	\$ 3,279.00	113	\$ 4,125.00	130	\$ 6,515.00	98	\$ 5,550.00	81	\$ 3,575.00
Nolle Prosequi/Dismissed/Not Guilty	93		109		100		139		88		108	
Transferred to General Sessions Court	26		28		25		38		14		6	
Voided	5		4		1		13		9		9	
Fine Suspended	2	\$ 100.00	1	\$ 25.00	0		2	\$ 525.00	0			
Code Enforcement Tried in Absence	2	\$ 2,175.00	1	\$ 1,087.50	0		4	\$ 4,350.00	0			
Code Enforcement Fine Suspended	0				0		0		1	\$ 1,087.50		
Code Enforcement Fine Paid	0				0		1	\$ 187.50				
Code Enforce Scheduled Time Payment	0				0		0					
Code Enforcement Nolle Prosequi	3				0		0					
Total	341	\$ 46,847.71	495	\$ 74,218.52	362	\$ 48,901.32	517	\$ 82,156.97	339	\$ 58,089.41	373	\$ 59,523.47

Cases Disposed	January		February		March		April		May		June	
	# of Cases Disposed	Fine Amounts	# of Cases Disposed	Fine Amounts	# of Cases Disposed	Fine Amounts	# of Cases Disposed	Fine Amounts	# of Cases Disposed	Fine Amounts	# of Cases Disposed	Fine Amounts
Paid	90	\$ 13,922.63	166	\$ 26,705.88	79	\$ 12,964.64	180	\$ 30,112.15	199	\$ 32,761.16	151	\$ 23,164.13
Served Time	8	\$ 6,832.50	18	\$ 14,080.00	27	\$ 33,597.50	6	\$ 7,977.50	15	\$ 13,092.50	21	\$ 23,154.00
Scheduled Time Payment	5	\$ 1,956.71	16	\$ 7,911.79	16	\$ 6,756.46	11	\$ 4,067.30	11	\$ 5,528.95	18	\$ 5,209.77
NRVC	25	\$ 6,004.00	31	\$ 8,149.75	34	\$ 7,480.73	42	\$ 10,192.80	35	\$ 8,401.00	43	\$ 7,882.76
Tried in Absence	16	\$ 14,453.25	14	\$ 8,490.00	12	\$ 9,944.50	6	\$ 4,602.50	9	\$ 8,982.00	10	\$ 7,945.00
Parking Tickets Paid	49	\$ 1,825.00	68	\$ 2,610.00	51	\$ 2,650.00	53	\$ 1,950.00	65	\$ 3,075.00	78	\$ 4,842.50
Nolle Prosequi/Dismissed/Not Guilty	93		97		112		140		135		105	
Transferred to General Sessions Court	24		47		19		32		41		32	
Voided	13		11		13		7		4		17	
Fine Suspended	1	\$ 25.00			1	\$ 615.00	0		5	\$ 675.00	2	\$ 465.00
Code Enforcement Tried in Absence					2	\$ 2,175.00	9	\$ 9,787.50			1	\$ 1,087.50
Code Enforcement Fine Suspended							0					
Code Enforcement Fine Paid							0					
Code Enforce Scheduled Time Payment							0					
Code Enforcement Nolle Prosequi	4				1		4		2		2	
Total	328	\$ 45,019.09	468	\$ 67,947.42	367	\$ 76,183.83	490	\$ 68,689.75	521	\$ 72,515.61	480	\$ 73,750.66

Cases Disposed	Cumulative Totals	
	# of Cases Disposed	Fine Amounts
Paid	1455	\$ 243,164.41
Served Time	177	\$ 183,654.50
Scheduled Time Payment	179	\$ 74,921.91
NRVC	352	\$ 84,857.81
Tried in Absence	129	\$ 98,374.00
Parking Tickets Paid	981	\$ 43,846.50
Nolle Prosequi/Dismissed/Not Guilty	1319	\$ -
Transferred to General Sessions Court	332	\$ -
Voided	106	\$ -
Fine Suspended	14	\$ 2,430.00
Code Enforcement Tried in Absence	19	\$ 20,662.50
Code Enforcement Fine Suspended	1	\$ -
Code Enforcement Fine Paid	1	\$ 1,087.50
Code Enforce Scheduled Time Payment	0	\$ 187.50
Code Enforcement Nolle Prosequi	16	\$ -
Total	5081	\$ 773,843.76

Municipal Court Monthly Report (Fiscal Year 2026)

Cases Disposed	July		August		September		October		November		December	
	# of Cases Disposed	Fine Amounts Imposed	# of Cases Disposed	Fine Amounts Imposed	# of Cases Disposed	Fine Amounts Imposed	# of Cases Disposed	Fine Amounts Imposed	# of Cases Disposed	Fine Amounts Imposed	# of Cases Disposed	Fine Amounts Imposed
Paid	174	\$ 23,616.13	229	\$ 31,606.10	211	\$ 30,158.53	191	\$ 27,408.05	60	\$ 11,061.75	202	\$ 28,450.81
Served Time	15	\$ 18,330.00	18	\$ 28,297.50	10	\$ 12,062.50	12	\$ 16,230.00	17	\$ 14,772.50	17	\$ 13,935.00
Scheduled Time Payment	20	\$ 6,892.61	30	\$ 8,101.55	21	\$ 3,558.68	20	\$ 4,814.81	12	\$ 1,748.00	19	\$ 5,387.95
NRVC	40	\$ 6,858.00	77	\$ 15,042.75	37	\$ 5,904.50	25	\$ 4,145.64	19	\$ 5,100.00	39	\$ 11,865.27
Tried in Absence	9	\$ 8,917.50	19	\$ 17,319.50	6	\$ 3,150.63	26	\$ 21,134.11	7	\$ 7,762.50	14	\$ 8,993.00
Parking Tickets Paid	119	\$ 7,875.00	89	\$ 8,078.00	53	\$ 3,318.50	57	\$ 4,387.75	28	\$ 2,412.00	35	\$ 3,548.25
Nolle Prosequi/Dismissed/Not Guilty	124		150		129		177		76		138	
Transferred to General Sessions Court	35		29		51		28		35		27	
Voided	29		11		7		7		12		6	
Fine Suspended	3	\$ 670.00	1	\$ 25.00			2					
Code Enforcement Tried in Absence			2	\$ 2,175.00								
Code Enforcement Fine Suspended												
Code Enforcement Fine Paid			1	\$ 150.00								
Code Enforce Scheduled Time Payment												
Code Enforcement Nolle Prosequi	1		1				1	\$ 525.00				
Total	569	\$ 73,159.24	657	\$ 110,795.40	525	\$ 58,153.34	546	\$ 78,645.36	266	\$ 42,856.75	497	\$ 72,180.28
Cases Disposed	January		February		March		April		May		June	
	# of Cases Disposed	Fine Amounts Imposed	# of Cases Disposed	Fine Amounts Imposed	# of Cases Disposed	Fine Amounts Imposed	# of Cases Disposed	Fine Amounts Imposed	# of Cases Disposed	Fine Amounts Imposed	# of Cases Disposed	Fine Amounts Imposed
Paid	45	\$ 10,031.38	109	\$ 15,977.19								
Served Time	15	\$ 9,403.00	9	\$ 10,775.00								
Scheduled Time Payment	15	\$ 3,178.91	10	\$ 1,236.85								
NRVC	14	\$ 2,891.38	32	\$ 6,572.13								
Tried in Absence	6	\$ 6,327.50	9	\$ 8,283.89								
Parking Tickets Paid	42	\$ 3,308.25	49	\$ 3,508.00								
Nolle Prosequi/Dismissed/Not Guilty	113		100									
Transferred to General Sessions Court	10		23									
Voided	9		14									
Fine Suspended												
Code Enforcement Tried in Absence												
Code Enforcement Fine Suspended												
Code Enforcement Fine Paid												
Code Enforce Scheduled Time Payment												
Code Enforcement Nolle Prosequi	1	\$ 1,087.50										
Total	270	\$ 36,227.92	355	\$ 46,353.06								

Cases Disposed	Cummulative Totals																			
	# of Cases Disposed	Fine Amounts Imposed																		
Paid	1221	\$ 168,323.56																		
Served Time	113	\$ 114,417.50																		
Scheduled Time Payment	50	\$ 34,919.36																		
NRVC	283	\$ 58,379.67																		
Tried in Absence	96	\$ 81,888.63																		
Parking Tickets Paid	472	\$ 36,435.75																		
Nolle Prosequi/Dismissed/Not Guilty	1007	\$ -																		
Transferred to General Sessions Court	238	\$ -																		
Voided	95	\$ -																		
Fine Suspended	6	\$ 695.00																		
Code Enforcement Tried in Absence	2	\$ 2,175.00																		
Code Enforcement Fine Suspended	0	\$ -																		
Code Enforcement Fine Paid	1	\$ -																		
Code Enforce Scheduled Time Payment	0	\$ 150.00																		
Code Enforcement Nolle Prosequi	4	\$ 1,087.50																		
Total	3685	\$ 518,371.35																		

Municipal Court Monthly Report (Fiscal Year 2026)

Cases Filed	July	August	September	October	November	December	Cases Filed	Cummulative Totals
	# of Cases Filed	# of Cases Filed	# of Cases Filed	# of Cases Filed	# of Cases Filed	# of Cases Filed		# Cases Filed
Driving under the influence	3	3	1	1	1	1		
Driving under suspension	20	20	12	12	22	14	Driving under the influence	11
Seatbelt Violations	1	2	1	4	2	2	Driving under suspentsion	123
Child Restraint Violations	0	0	0	0	0	1	Seatbelt Violations	15
Uninsured Motor Vehicle	1	10	2	6	4	3	Child Restraint Violations	1
Speeding	19	33	20	22	94	107	Uninsured Vehicle Violations	33
Reckless Driving	1	2	2	0	1	1	Speeding	418
Drug Charges	10	17	13	7	6	1	Reckless Driving	9
Felony Charges	7	18	20	7	14	16	Drug Charges	66
Other Criminal Violations	36	57	35	44	34	36	Felony Charges	107
Other Traffic Violations	214	240	184	214	96	80	Other Criminal Violations	303
Parking tickets	206	91	39	89	55	56	Other Traffic Violations	1233
Voided	25	10	10	7	9	6	Parking Tickets	703
Code Enforcement	3	1	1	1	0	0	Voided	90
Total	546	504	340	414	338	324	Code Enforcement Violations	8
Cases Filed	January	February	March	April	May	June	Total	3120
Driving under the influence	1	0						
Driving under suspension	13	10						
Seatbelt Violations	1	2						
Child Restraint Violations	0	0						
Uninsured Motor Vehicle	5	2						
Speeding	87	36						
Reckless Driving	1	1						
Drug Charges	7	5						
Felony Charges	14	11						
Other Criminal Violations	39	22						
Other Traffic Violations	107	98						
Parking Tickets	88	79						
Voided	11	12						
Code Enforcement Violations	0	2						
Total	374	280						

Building Department Monthly Report Statistics (2026)

Number of Inspections by Building Official/Building Inspector

Inspection Type	January	February	March	April	May	June	July	August	September	October	November	December	Total
Certificates of Occupancy Issued	6	0											
Stop Work	0	4											
Inspections	152	142											
Plan Review & Sign	0	0											
Business License Inspections For New Businesses	4	3											
Totals	162	149											

Boards and Commissions Applications & Applications Heard

Boards and Commissions	January	February	March	April	May	June	July	August	September	October	November	December	Total
Construction Board of Appeals	0	0											
Technical Review Committee	0	0											
Totals	0	0											

Code Enforcement Issues

Enforcement	January	February	March	April	May	June	July	August	September	October	November	December	Total
Calls/Complaints	3	7											
Site Visits	35	41											
Courtesy Notices sent or In person notice	9	14											
Sign Violations	3	8											
Contact with Business Owners Regarding Business Licenses	7	2											
Other Issues Addressed and Meetings	3	4											
Totals	60	76											

Planning & Community Development Monthly Report Statistics (2026)

Boards and Commissions Applications & Applications Heard													
Boards & Commissions	January	February	March	April	May	June	July	August	September	October	November	December	Total
Architectural Review Board	3	6											
Board of Zoning Appeals	3	7											
Planning Commission	1	1											
Community Appearance Board	2	2											
Construction Board of Appeals	0	0											
Totals	9	16	0	0	0	0	0	0	0	0	0	0	0

Planning & Community Development Monthly Report – February 2026

Al Joseph, Main Street Coordinator, Planning & Community Development

- Met with Chef Bear to discuss new business opening opportunity
- Attended the paving precon meeting with city engineering and Green Wave contracting
- Attended the monthly Arts Commission meeting
- Guest speaker at Pawleys Island Kiwanis Club
- Attended the SC250 planning meeting – Twice monthly meetings to plan the 10 events in June and July of this year
- Attended the annual 3-day Governors Conference on Travel and Tourism
- Attended 1st quarter Main Street Meeting in Columbia, SC
- Meeting with Natrona Simmons to discuss placement of the Foxes on Front
- Meeting with members of the Foxes on Front committee to discuss placement of the display in Constitution Park
- Meeting with an attraction and entertainment company to discuss options for Georgetown
- Meeting with owner and general manager of Corner Tavern to discuss reopen date due to sewer work, possible relocation and a rebranding/re-grand opening event
- Meeting with Michael Caldwell, owner of Indigo Mercantile, to discuss opening a lunch takeout business in the Mercantile
- Meeting with the Goss Advertising Agency to discuss alternative marketing opportunities for Historic Business District businesses
- Attended the mayors forum at the Winyah Auditorium
- Attended the first Art/Wine Walk planning meeting – We will meet monthly to plan for the September 12/13 event
- Met with Jennifer Boyer to discuss Main Street job duties
- Meeting with the owner of Mt. Pleasant Magazine to discuss guests for the new “Georgetown – The Podcast”

Clarissa Tindall, Zoning Administrator, Planning & Community Development

Meetings (Jennifer Boyer attended as well):

- 1 ARB Meeting
- 1 BZA Meeting
- 1 PC Meeting
- 1 City Council Meeting
- Meetings with citizens about various projects
- Meetings with potential contractors for Unified Development Ordinance

For Boards/Commissions/Council:

- Staff reports, agenda, public notification, and creation of packets for the Architectural Review Board Regular Meeting, Drafting of Board Orders and COA's
- Staff report, agenda, public notification, and creation of packets for the Board of Zoning Appeals Regular Meeting, Drafting of Board Orders
- Staff report, agenda, and creation of packets for the Planning Commission Regular Meeting
- Completion of 8 Compliance inspections for Design Boards
- Update of format for all BZA Applications

Applications and Permits:

- Intake of 5 ARB Applications
- Intake of 6 BZA Applications
- Intake of 2 CAB Applications
- Intake of 1 Rezoning Application
- 2 Encroachment Permits
- 2 new STVR Application
- 3 Sign Permits
- 1 Temporary Sign Permit
- 5 Tree Investigation Forms and subsequent site visits
- 2 Subdivision Plat Applications
- 1 certification of survey of record
- 1 reconfiguration plat, approve at PC MOI
- Review of Building Permits, communication with developers regarding revisions
- Review of City Projects

Public:

- Talked with property owners and project coordinators
- Meetings with developers about conceptual projects
-

Zoning Letters:

- 1 Zoning Determination Letter
- 2 Address Correction/verification letters

Ordinance Updates:

- One parking text amendment

Other:

- Leadership Georgetown Class
- Continued corrections to Zoning Map
- Building permit approvals
- Business license approvals
- Building out electronic filing system for 2026
- 26-27 budget work

Jennifer Boyer, Planning Director, Planning & Community Development

Meetings:

- Attended various meetings regarding economic development, affordable housing, workforce housing, and other development opportunities.
- Met with Marilyn Hemingway regarding Gullah Geechee Chamber Foundation.
- Met with HTC representatives to discuss ongoing concerns regarding addressing of properties within the city.
- Met with various individuals regarding the SCOR program and how the city could apply for grant funding.
- Provided introductions to several firms regarding their insight and capabilities in aiding the city with its Comprehensive Plan and UDO amendments.

City Hall Project

- Met with PNC and Furniture Team for City Hall.
- Met at the new City Hall with design team to discuss interior finishes.

Other

- Met with staff to discuss their responsibilities, general introductions.
- Forerunner training.
- Reorder/updates to department record keeping system
- Budget
 - Preparation of FY 26/27 budget.
 - Attended first budget review meeting.

Streater Mitchum, Executive Director, Friends of the Kaminski House

- February marked an exciting transition month as we reopened the Kaminski House gift shop following renovations. With floors refinished, lighting updated, and cosmetic improvements completed, the refreshed space enhances the overall visitor experience and supports earned revenue growth.
- During the month of February, we welcomed visitors from 23 states and 3 countries, continuing to demonstrate the Kaminski House's broad geographic reach even during the winter season.
- Our dedicated volunteers contributed approximately 78 hours in February, supporting behind-the-scenes projects and preparation efforts essential to the museum's ongoing operations and long-term sustainability.

-
- We continue to see strong momentum in private event rentals as we move into the spring season. Through the end of June, we have more than 20 weddings and special events scheduled on the lawn. These events bring significant out-of-town guests to Georgetown, supporting local tourism, hospitality partners, and broader economic activity.
 - Operationally, we are working closely with the Georgetown 250 Committee to coordinate and plan upcoming events that will serve both our local community and visitors. We look forward to officially releasing the event calendar next month and sharing the exciting lineup of programs tied to this historic milestone.
 - As of early February, the Kaminski House gift shop has officially reopened following completion of the renovation project. We have fully moved back into the space and resumed normal operations. This upfit was fully funded by the Friends of the Kaminski House through previously donated reserve funds that were restricted specifically for maintenance and improvements. The project included refinished floors, updated lighting, and cosmetic upgrades that enhance both the visitor experience and retail environment. We are grateful for the Friends' stewardship in making this improvement possible without impacting operating funds.

MAYOR
JAY DOYLE

CITY ADMINISTRATOR
SCOTT WHITTIER

CITY CLERK
STEPHANIE BUCCIONE



COUNCIL MEMBERS
VACANT
MAYOR PRO TEMPORE

BRUCE CARL
ERIN ETHRIDGE
SHARON MELTON
HOBSON H. MILTON
JESSIE WALKER
TAMIKA WILLIAMS-OBENG

Georgetown Police Department
William Pierce Jr, Chief of Police
Office: (843) 545-4300
Fax: (843) 520-5848

February 2026

**Honorable Mayor Jay Doyle
And Members of City Council
City of Georgetown, South Carolina**

Dear Mayor Doyle and Council Members:

The following highlights reflect recent activities and community engagement efforts involving the Georgetown Police Department during the month of **February**:

Willowbank Traffic Study – Palmetto Street

Between January 28 and February 15, 2026, the Georgetown Police Department conducted targeted traffic monitoring and enforcement on Palmetto Street in response to residents' concerns regarding speeding and neighborhood traffic volume. Officers noted that during peak travel times, congestion at nearby intersections, particularly along Church Street at Black River Road and Wood Street, occasionally caused motorists to divert through the Willowbank neighborhood via Palmetto Street as an alternate route. While this diversion increased traffic volume in the neighborhood, observed speeds generally remained within the posted limit. Residents have also inquired about the potential use of pneumatic traffic tubes for additional traffic data collection, which falls under the authority of the South Carolina Department of Transportation (SCDOT).

Speed Measuring Device (SMD) Certification Training

From February 17 through February 20, 2026, personnel from the Georgetown Police Department attended Speed Measuring Device (SMD) certification training hosted by the Georgetown County Sheriff's Office. This training provides officers with instruction and certification in the proper use and calibration of speed measuring equipment, including radar and related traffic enforcement technology. Certification ensures officers are properly trained to operate this specialized equipment in accordance with legal and evidentiary standards. Participation in this training supports the department's ongoing efforts to maintain proficiency in traffic enforcement practices and to promote roadway safety throughout the community.

Corporal Promotion – February 17

On February 17, 2026, Officer James Smith was selected and promoted to the rank of Corporal to fill a vacant patrol supervisor position. Corporal Smith brings significant prior law enforcement experience to the Georgetown Police Department, including a distinguished career with the New York City Police Department.

Drawer 939
Georgetown, SC 29442

His experience, professionalism, and leadership perspective are valuable assets to the organization and will further strengthen the department's supervisory ranks.

Greg's Groceries – February 17

Georgetown Police Department officers participated in a Greg's Groceries food-packing event held at the Hadwin-White Subaru dealership in Conway. Officers Brantley, Davis, and McKay joined numerous other law enforcement agencies and community partners in preparing hundreds of boxes of nonperishable food for distribution throughout the region. Greg's Groceries, in partnership with Serve & Connect, works to address food insecurity by providing families with food boxes containing enough groceries to support a household for approximately one week. Dozens of food boxes were brought back to Georgetown for distribution to residents within the city who may be experiencing temporary hardship. Participation in this initiative reflects the department's continued commitment to community partnership and service beyond traditional law enforcement responsibilities.

LEN Checkpoint – February 27

On Friday, February 27, 2026, the Georgetown Police Department, in partnership with the Georgetown County Sheriff's Office, hosted a Law Enforcement Network (LEN) traffic safety checkpoint within the City of Georgetown. The 15th Circuit Law Enforcement Network (LEN) includes officers from participating agencies across Georgetown and Horry Counties, including the South Carolina Highway Patrol. These collaborative operations focus on improving roadway safety and reducing traffic-related injuries and fatalities through coordinated enforcement and public visibility. During the operation, officers conducted safety checks on approximately 940 vehicles traveling through the checkpoint. As a result of the enforcement effort, officers issued 37 uniform traffic tickets and 3 warning citations. The operation also resulted in four arrests for traffic-related offenses and three arrests for narcotics-related violations.

Please let me know if you need any additional information regarding these or other matters.

Respectfully,

*William Pierce, Chief of Police
Georgetown Police Department*

Enforcement	January	February	March	April	May	June	July	August	September	October	November	December	Total
CAD Activity	4161	3295											7456
Calls for Service	740	616											1356
Incident Reports	109	68											177
Zone 1	14	16											30
Zone 2	42	11											53
Zone 3	53	41											94
Street Crimes													
Incident Reports	3	7											10
Traffic Stops	47	39											86
Arrest	4	7											11
Drug Cases	1	4											5
Weapon Recovered	0	1											1
Arrest	69	46											115
Warrants Served	27	18											45
Traffic Accidents													
Responded To	36	41											77
TR310s completed	37	40											77
Traffic Stops	625	481											1106
Uniform Traffic Ticket	257	158											415
Male	167	99											266
Female	90	59											149
Caucasian	122	90											212
African American	109	52											161
Hispanic	20	9											29
Other	6	7											13
Warning/Public Contact	423	362											785
Male	288	219											507
Female	195	143											338
Caucasian	256	196											452
African American	142	124											266
Hispanic	8	17											25
Other	17	25											42
Property Check	2717	2130											4847

PUBLIC WORKS CURBSIDE COLLECTIONS MONTHLY REPORT (FY 2025-2026)

Division	Task	Jul-25	Aug-25	Sep-25	Oct-25	Nov-25	Dec-25	Jan-26	Feb-26	Mar-26	Apr-26	May-26	Jun-26	Cummulative
Curbside Debris	Yard Waste: Leaves, Grass & Straw collected	82	86	140	107	110	141	157	86					909
Curbside Debris	Brown & White Goods collected (Net Tons)	64	107	80	60	55	12	10	16					404
Garbage Collections	Residential Solid Waste Collection (Net Tons)	368	334	361	352	269	367	312	272					2,635
Recycle Collections	Recyclables Collected (Net Tons)	17	14	15	16	14	16	16	13					120
	Monthly Totals (Net Tons)	530	541	595	535	447	537	496	388	-	-	-	-	

PUBLIC WORKS MONTHLY WORK ORDERS REPORT (FY 2025-2026)

Division	Task	Jul-25	Aug-25	Sep-25	Oct-25	Nov-25	Dec-25	Jan-26	Feb-26	Mar-26	Apr-26	May-26	Jun-26	Cummulative
Solid Waste Maintenance	New roll out cart deliveries, and/or replacements, recycle bins and special events.	75	43	45	50	28	32	37	31					341
Streets	Sidewalk, curbing and boardwalk repairs.	4	5	5	14	15	30	14	10					97
Facility Maintenance	City parks and restrooms, and facility maintenance repairs.	3	6	34	27	8	16	8	15					117
	Monthly Work Orders Totals	82	54	84	91	51	78	59	56	-	-	-	-	555

MAYOR
JAY DOYLE

CITY ADMINISTRATOR
SCOTT WHITTIER

CITY CLERK
STEPHANIE BUCCIONE



COUNCIL MEMBERS
JESSIE M. WALKER
MAYOR PRO TEMPORE

BRUCE CARL
ERIN ETHRIDGE
SHARON MELTON
HOBSON H. MILTON
TAMIKA WILLIAMS-OBENG

Georgetown City Fire Department
Charles W. Cribb, Fire Chief
Office: (843) 545-4200
Fax: (843) 527-1650

Risk Management February 2026 Report

Risk Management

Department	SCMIT/SCMIRF	Loss Description
Public Works	SCMIT – 0 SCMIRF –2	1- MVA 2- Leak at Office
Water Utilities	SCMIT – 0 SCMIRF – 0	
Electric Utilities	SCMIT – 0 SCMIRF – 0	
Fleet	SCMIT – 0 SCMIRF –0	
Finance	SCMIT – 0 SCMIRF – 0	
Fire	SCMIT – 0 SCMIRF – 0	
Administration	SCMIT – 0 SCMIRF – 0	
Engineering	SCMIT – 0 SCMIRF – 0	
Municipal Court	SCMIT – 0 SCMIRF – 0	
Planning & Community Development	SCMIT – 0 SCMIRF – 0	
Police Department	SCMIT – 0 SCMIRF –0	

WATER - WASTEWATER - STORMWATER UTILITY REPORT (FY 2020)

Description of Work Performed	Jul-19	Aug-19	Sep-19	Oct-19	Nov-19	Dec-19	Jan-20	Feb-20	Mar-20	Apr-20	May-20	Jun-20	Cumulative
Water Treatment Plant (WTP)													
Filtered Water Total (MG)	36.148	36.028	34.942	35.346	30.934	29.822	27.638	26.451	28.422	27.102	32.469	28.558	373.86
Average Daily Flow Finished Water (MGD)	1.166	1.162	1.165	1.140	1.031	0.962	0.892	0.912	0.917	0.903	1.047	0.952	12.249
King Well (MG)	6.571	6.402	6.449	6.462	6.201	6.437	6.391	5.998	6.404	6.387	6.781	6.374	76.857
Maryville Well (MG)	8.110	6.694	5.968	6.517	5.890	6.101	7.228	6.834	7.684	7.541	5.885	6.807	81.259

Wastewater Treatment Plant (WWTP)

Influent Flow Total (MG)	109.241	106.426	141.725	104.576	113.434	156.034	139.421	157.692	163.034	119.247	131.099	147.438	1589.367
Average Daily Influent Flow (MGD)	3.524	3.433	4.724	3.373	3.781	5.033	4.497	5.632	5.259	3.975	4.229	4.915	52.375
Effluent Flow Total (MG)	107.234	94.499	121.308	94.499	147.861	198.72	133.819	167.524	117.287	107.234	96.997	126.464	1513.446
Average Daily Effluent Flow (MGD)	3.459	3.048	4.044	3.048	4.929	6.410	4.317	5.983	3.783	3.574	3.129	4.215	49.939
Rainfall Total (Inches)	5.26	8.09	12.13	2.69	3.4	8.04	1.6	5.38	4.36	3.84	4.68	5.46	64.93

Water Distribution

Work Orders Completed	82	70	55	66	75	74	81	143	117	71	59	83	976
Water Leaks Repairs	36	26	18	21	28	34	27	19	34	16	21	18	298
Water Meters Replacements	12	1	4	5	8	3	9	28	0	3	3	5	81
Locates Completed	209	321	133	148	100	146	121	123	123	125	109	125	1783

Wastewater Collection

Work Orders Completed	23	41	31	40	57	68	67	60	76	41	60	51	615
Backup Responses	6	6	11	12	16	14	50	49	60	32	48	35	339
Locates Completed	209	321	133	148	100	146	121	123	123	125	109	125	1783
Routine Line Cleaning													

Maintenance

Work Orders Completed	22	0	20	26	19	20	28	19	22	22	21	31	250
Work Orders on Pump Stations Completed	12	0	9	10	11	18	7	6	4	6	5	9	97
Work Orders for the WWTP Completed	8	0	3	0	1	1	2	1	5	6	3	2	32
Work Orders for the WTP Completed	0	0	0	0	2	0	8	0	1	0	0	0	11

Stormwater

Work Orders Completed	11	22	8	13	8	16	11	4	4	5	9	17	128
Locates Completed	209	321	133	148	100	146	121	123	123	125	106	125	1780
Routine Line and Ditch Cleaning													

WATER - WASTEWATER - STORMWATER UTILITY REPORT (FY 2021)

Description of Work Performed	Jul-20	Aug-20	Sep-20	Oct-20	Nov-20	Dec-20	Jan-21	Feb-21	Mar-21	Apr-21	May-21	Jun-21	Cumulative
Water Treatment Plant (WTP)													
Filtered Water Total (MG)	32.000	40.197	29.645	29.429	27.061	29.323	32.079	28.295	32.522	35.309	39.721	30.633	386.214
Average Daily Flow Finished Water (MGD)	1.032	1.297	0.988	0.949	0.902	0.946	1.035	1.011	1.049	1.177	1.281	1.021	12.688
King Well (MG)	6.457	6.542	6.373	6.446	6.259	6.515	6.474	5.887	6.529	6.543	6.513	6.361	76.899
Maryville Well (MG)	7.078	5.192	7.471	7.686	7.372	7.779	7.694	6.900	7.786	7.501	7.780	7.622	87.861

Wastewater Treatment Plant (WWTP)

Influent Flow Total (MG)	149.165	190.492	165.163	161.879	152.729	124.042	152.305	181.193	136.020	96.761	87.472	93.985	1691.206
Average Daily Influent Flow (MGD)	4.812	6.145	5.505	5.222	5.091	4.001	4.913	6.471	4.388	3.225	2.822	3.133	55.728
Effluent Flow Total (MG)	125.819	152.274	134.207	124.529	156.605	114.882	152.134	185.883	120.654	83.403	62.241	83.403	1496.034
Average Daily Effluent Flow (MGD)	4.059	4.912	4.474	4.017	5.220	3.706	4.908	6.639	3.892	2.780	2.008	2.780	49.395
Rainfall Total (Inches)	7.230	13.010	7.380	3.420	3.770	4.910	4.770	5.100	1.940	0.240	1.630	7.400	60.800

Water Distribution

Work Orders Completed	70	82	63	82	71	71	72	75	78	91	84	60	899
Water Leak Repairs	25	26	14	27	23	17	17	26	22	37	22	26	282
Water Meter Replacements	0	3	2	5	1	0	1	2	1	1	10	0	26
Locates Completed	142	132	133	180	128	121	167	135	190	162	110	143	1743

Wastewater Collection

Work Orders Completed	34	38	35	47	44	64	66	47	57	65	42	29	568
Backup Responses	30	24	25	37	36	45	35	44	38	31	31	12	388
Locates Completed	142	132	133	180	128	121	167	135	190	162	110	143	1743
Routine Line Cleaning													

Maintenance

Work Orders Completed	40	21	21	31	29	27	29	26	33	26	35	39	357
Work Orders on Pump Stations Completed	15	9	2	14	2	7	2	13	0	1	0	0	65
Work Orders for the WWTP Completed	8	0	6	11	7	4	2	1	4	4	2	7	56
Work Orders for the WTP Completed	0	0	0	0	0	0	0	0	0	0	4	0	4

Stormwater

Work Orders Completed	11	18	5	4	5	5	2	7	5	4	2	5	73
Locates Completed	142	132	133	180	128	121	167	135	190	162	110	143	1743
Routine Line and Ditch Cleaning													

WATER - WASTEWATER - STORMWATER UTILITY REPORT (FY 2022)

Description of Work Performed	Jul-21	Aug-21	Sep-21	Oct-21	Nov-21	Dec-21	Jan-22	Feb-22	Mar-22	Apr-22	May-22	Jun-22	Cumulative
Water Treatment Plant (WTP)													
Filtered Water Total (MG)	28.769	28.224	27.210	27.563	25.356	22.701	28.197	26.836	29.322	28.109	35.701	34.570	342.558
Average Daily Flow Finished Water (MGD)	0.928	0.910	0.907	0.889	0.845	0.732	0.910	0.958	0.946	0.937	1.152	1.152	11.266
King Well (MG)	6.493	6.610	6.305	6.537	6.394	6.544	6.588	3.893	6.679	6.248	6.539	7.094	75.924
Maryville Well (MG)	7.626	7.738	7.307	7.233	7.383	7.579	7.734	6.933	7.676	7.396	7.652	8.081	90.338

Wastewater Treatment Plant (WWTP)													
Influent Flow Total (MG)	130.787	158.660	113.273	97.988	87.184	76.937	97.785	92.245	100.621	110.320	96.836	80.254	1242.890
Average Daily Influent Flow (MGD)	4.219	5.118	3.776	3.161	2.906	2.482	3.154	3.294	3.246	3.677	3.124	2.675	40.832
Effluent Flow Total (MG)	106.432	141.910	95.851	85.893	84.952	84.109	107.308	90.028	85.893	84.244	78.633	70.584	1115.837
Average Daily Effluent Flow (MGD)	3.433	4.578	3.195	2.771	2.832	2.713	3.462	3.215	2.771	2.808	2.537	2.353	36.668
Rainfall Total (Inches)	8.750	6.260	4.340	2.270	1.680	3.780	3.320	1.450	3.940	2.970	2.600	2.950	44.310

Water Distribution													
Work Orders Completed	73	75	59	54	61	60	61	62	71	66	71	71	784
Water Leak Repairs	21	21	20	22	18	24	23	30	18	16	21	23	257
Water Meter Replacements	4	2	0	4	1	0	1	2	3	1	0	0	18
Locates Completed	80	130	141	123	121	85	136	91	120	144	117	147	1435

Wastewater Collection													
Work Orders Completed	46	30	48	28	50	57	55	59	69	48	43	38	571
Backup Responses	23	18	21	16	20	21	28	23	21	14	18	13	236
Locates Completed	80	130	141	123	121	85	136	91	120	144	117	147	1435
Routine Line Cleaning													0

Maintenance													
Work Orders Completed	37	41	38	19	34	28	30	25	29	26	27	22	356
Work Orders on Pump Stations Completed	0	14	7	3	9	9	6	5	4	6	5	0	68
Work Orders for the WWTP Completed	2	4	2	4	5	6	5	6	3	6	4	5	52
Work Orders for the WTP Completed	1	1	4	1	0	0	0	0	2	0	0	1	10

Stormwater													
Work Orders Completed	5	9	3	9	0	1	0	0	1	5	5	9	47
Locates Completed	80	130	141	123	121	85	136	91	120	144	117	147	1435
Routine Line and Ditch Cleaning													

WATER - WASTEWATER - STORMWATER UTILITY REPORT (FY 2023)

Description of Work Performed	Jul-22	Aug-22	Sep-22	Oct-22	Nov-22	Dec-22	Jan-23	Feb-23	Mar-23	Apr-23	May-23	Jun-23	Cumulative	
Water Treatment Plant (WTP)														
Filtered Water Total (MG)	31.649	30.890	29.822	29.557	26.944	31.701	29.558	24.533	28.842	28.939	31.402	31.241	355.078	260.446
Average Daily Flow Finished Water (MGD)	1.021	0.996	0.994	0.953	0.898	1.023	0.953	0.876	0.930	0.965	1.013	1.041	11.663	174.515
King Well (MG)	6.505	6.734	6.256	6.749	6.260	6.851	6.463	5.832	6.247	6.260	6.613	6.261	77.031	37.676
Maryville Well (MG)	7.472	7.455	7.057	7.362	7.161	7.914	7.517	6.472	7.432	7.200	7.547	7.124	87.713	43.292
														515.929
Wastewater Treatment Plant (WWTP)														
Influent Flow Total (MG)	95.496	97.347	101.359	107.097	89.125	93.496	98.882	133.574	107.478	106.761	99.984	101.671	1232.270	
Average Daily Influent Flow (MGD)	3.081	3.140	3.379	3.455	2.971	3.016	3.190	4.771	3.467	3.559	3.225	3.389	40.643	
Effluent Flow Total (MG)	74.918	90.397	97.207	99.065	86.630	84.880	91.613	133.576	89.158	91.973	91.334	102.831	1133.582	600.485
Average Daily Effluent Flow (MGD)	2.417	2.916	3.240	3.196	2.888	2.738	2.955	4.771	2.876	3.066	2.946	3.428	37.437	648.337
Rainfall Total (Inches)	6.260	5.020	7.260	1.320	3.030	1.140	3.960	4.470	1.550	4.440	5.670	4.940	49.060	25.030
														1248.822
Water Distribution														
Work Orders Completed	62	64	86	73	68	93	72	72	98	59	47	40	834	388
Water Leak Repairs	19	20	9	24	20	55	40	25	55	10	13	11	301	
Water Meter Replacements	1	3	2	4	5	3	3	7	3	5	2	0	38	
Locates Completed	131	136	107	104	92	124	158	138	200	154	111	116	1571	877
Wastewater Collection														
Work Orders Completed	40	37	45	39	41	49	48	76	36	32	36	27	506	255
Backup Responses	17	16	12	19	17	24	28	29	20	9	11	12	214	
Locates Completed	131	136	107	104	92	124	158	138	200	154	111	116	1571	
Routine Line Cleaning													0	
Maintenance														
Work Orders Completed	28	31	40	24	32	21	27	37	33	22	25	36	356	180
Work Orders on Pump Stations Completed	0	0	1	0	0	5	2	6	5	2	0	0	21	
Work Orders for the WWTP Completed	7	10	11	2	11	5	8	9	7	5	8	10	93	
Work Orders for the WTP Completed	0	3	8	6	0	0	3	3	5	0	1	1	30	
Stormwater														
Work Orders Completed	3	7	3	7	1	1	1	3	2	4	1	5	38	16
Locates Completed	131	136	107	104	92	124	158	138	200	154	111	116	1571	

WATER - WASTEWATER - STORMWATER UTILITY REPORT (FY 2024)

Description of Work Performed	Jul-23	Aug-23	Sep-23	Oct-23	Nov-23	Dec-23	Jan-24	Feb-24	Mar-24	Apr-24	May-24	Jun-24	Cumulative
Water Treatment Plant (WTP)													
Filtered Water Total (MG)	44.021	42.946	42.493	39.403	39.913	43.912	43.570	38.815	38.888	39.774	46.883	45.400	506.018
Average Daily Flow Finished Water (MGD)	1.420	1.385	1.416	1.271	1.208	1.417	2.476	1.386	1.254	1.326	1.252	1.513	1.444
King Well (MG)	1.250	0.000	0.000	0.000	2.111	0.000	0.000	0.000	0.000	0.000	0.000	0.000	3.361
Maryville Well (MG)	2.843	0.000	0.000	0.000	1.554	0.000	0.000	0.000	0.000	0.000	0.000	0.000	4.397

Wastewater Treatment Plant (WWTP)													
Influent Flow Total (MG)	102.216	113.355	112.102	110.947	100.477	146.368	148.057	127.875	153.289	118.127	100.823	85.513	1419.149
Average Daily Influent Flow (MGD)	3.297	3.657	3.736	3.578	3.349	4.722	4.776	4.567	4.945	3.938	3.252	2.850	3.889
Effluent Flow Total (MG)	98.360	113.689	95.166	97.640	96.533	146.949	150.476	126.276	130.836	111.994	95.101	63.192	1326.212
Average Daily Effluent Flow (MGD)	3.173	3.667	3.172	3.150	3.218	4.740	4.854	4.510	4.221	3.733	3.068	2.106	43.612
Rainfall Total (Inches)	8.010	5.870	3.030	3.910	3.250	12.629	2.080	3.980	5.070	2.060	3.890	2.630	56.409

677.875

422.000

Water Distribution													
Work Orders Completed	52	65	36	51	60	65	78	78	77	45	74	70	751
Water Leak Repairs	16	14	16	24	36	14	27	14	15	16	27	28	247
Water Meter Replacements	1	0	3	4	5	0	5	5	3	1	3	6	36
Locates Completed	113	110	172	307	278	230	292	348	254	262	287	258	2911

Wastewater Collection													
Work Orders Completed	30	34	28	51	43	34	67	71	26	37	41	32	494
Backup Responses	16	17	12	30	24	17	31	26	18	13	16	10	230
Locates Completed	113	110	172	307	278	230	292	348	254	262	287	258	2911

Maintenance													
Work Orders Completed	22	26	24	25	20	26	19	17	24	31	24	31	289
Work Orders on Pump Stations Completed	3	3	3	2	0	3	12	6	8	14	14	11	79
Work Orders for the WWTP Completed	3	2	2	7	6	2	6	3	5	4	2	7	49
Work Orders for the WTP Completed	1	1	1	1	0	1	1	1	1	1	3	2	14

Stormwater													
Work Orders Completed	2	3	10	1	1	3	10	4	1	3	1	6	45
Locates Completed	113	110	172	307	278	230	292	348	254	262	287	258	2911

1701

WATER - WASTEWATER - STORMWATER UTILITY REPORT (FY 2025)

Description of Work Performed	Jul-24	Aug-24	Sep-24	Oct-24	Nov-24	Dec-24	Jan-25	Feb-25	Mar-25	Apr-25	May-25	Jun-25	Cumulative
Water Treatment Plant (WTP)													
Filtered Water Total (MG)	43.848	41.947	39.745	41.078	35.932	38.908	44.198	33.451	37.714	41.040	42.844	40.978	481.683
Average Daily Flow Finished Water (MGD)	1.514	1.353	1.325	1.325	1.198	1.255	1.426	1.266	1.217	1.368	1.382	1.366	1.333
King Well (MG)	0.000	0.000	0.000	0.000	0.000	0.000	0.000	0.000	0.000	0.000	0.000	0.000	0
Maryville Well (MG)	0.000	0.000	0.000	0.000	0.000	0.000	0.000	0.000	0.000	0.000	0.000	0.000	0

Wastewater Treatment Plant (WWTP)													
Influent Flow Total (MG)	102.707	200.269	124.963	104.225	76.327	75.409	93.726	85.448	85.033	79.125	93.722	113.127	1234.081
Average Daily Influent Flow (MGD)	3.313	6.460	4.165	3.362	2.544	2.433	3.023	3.052	2.743	2.638	3.023	3.771	3.377
Effluent Flow Total (MG)	102.609	169.555	105.118	99.945	82.213	71.523	68.635	85.144	66.946	68.628	78.795	94.046	1093.157
Average Daily Effluent Flow (MGD)	3.310	5.470	3.504	3.224	2.740	2.307	2.214	3.041	2.160	2.288	2.542	3.135	2.995
Rainfall Total (Inches)	7.150	13.210	8.500	0.015	2.060	2.710	1.940	1.160	2.480	2.650	5.400	6.500	53.775

Water Distribution													
Work Orders Completed	51	57	66	67	68	59	84	68	64	82	47	80	793
Water Leak Repairs	23	25	26	23	34	30	36	26	15	17	13	11	279
Water Meter Replacements	3	0	1	7	0	1	0	9	6	5	3	45	80
Locates Completed	266	247	329	327	244	93	301	255	299	280	253	127	3021

Wastewater Collection													
Work Orders Completed	36	49	34	75	45	50	55	52	58	47	21	41	563
Backup Responses	18	24	13	39	34	30	36	29	37	20	10	22	312
Locates Completed	266	247	329	327	244	93	301	255	299	280	253	127	3021

Maintenance													
Work Orders Completed	34	29	26	32	24	27	19	23	20	25	23	22	304
Work Orders on Pump Stations Completed	12	15	9	8	11	9	8	9	9	11	8	15	124
Work Orders for the WWTP Completed	3	5	10	5	9	6	3	5	8	4	3	3	64
Work Orders for the WTP Completed	2	9	1	1	0	1	1	2	0	1	4	0	22

Stormwater													
Work Orders Completed	5	3	6	2	1	0	1	1	1	1	4	0	25
Locates Completed	266	247	329	327	244	93	301	255	299	280	253	127	3021

WATER - WASTEWATER - STORMWATER UTILITY REPORT (FY 2025)

Description of Work Performed	Jul-25	Aug-25	Sep-25	Oct-25	Nov-25	Dec-25	Jan-26	Feb-26	Mar-26	Apr-26	May-26	Jun-26	Cumulative
Water Treatment Plant (WTP)													
Filtered Water Total (MG)	41.883	37.854	38.921	36.735	34.422	37.032	35.223	34.804					296.874
Average Daily Flow Finished Water (MGD)	1.351	1.221	1.297	1.185	1.147	1.195	1.136	1.243					1.222
King Well (MG)	0.000	0.000	0.000	0.000	0.000	0.000	0.000	0.000					0
Maryville Well (MG)	0.000	0.000	0.000	0.000	0.000	0.000	0.000	0.000					0

Wastewater Treatment Plant (WWTP)													
Influent Flow Total (MG)	102.922	150.775	87.471	142.526	89.450	88.120	82.445	85.286					828.995
Average Daily Influent Flow (MGD)	3.320	4.864	2.916	4.598	2.982	2.843	2.660	3.046					3.404
Effluent Flow Total (MG)	83.879	131.537	74.347	121.370	89.413	92.345	77.320	68.441					738.652
Average Daily Effluent Flow (MGD)	2.706	4.243	2.478	3.915	2.980	2.979	2.494	2.444					3.030
Rainfall Total (Inches)	7.24	8.33	2.15	12.45	0.36	2.16	2.11	3.08					37.88

Water Distribution													
Work Orders Completed	90	112	85	66	61	95	83	88					680
Water Leak Repairs	18	22	23	25	4	30	14	25					161
Water Meter Replacements	34	33	22	2	4	16	17	1					129
Locates Completed	320	448	505	498	431	433	514	400					3549

Wastewater Collection													
Work Orders Completed	28	55	32	47	54	47	50	63					376
Backup Responses	16	32	13	24	37	33	35	39					229
Locates Completed	320	448	505	498	431	433	514	400					3549

Maintenance													
Work Orders Completed	21	23	26	28	22	61	54	51					286
Work Orders on Pump Stations Completed	12	13	10	15	11	19	28	14					122
Work Orders for the WWTP Completed	6	2	9	3	4	5	5	5					39
Work Orders for the WTP Completed	1	2	0	0	2	6	5	7					23

Stormwater													
Work Orders Completed	5	2	1	2	0	0	2	2					14
Locates Completed	320	448	505	498	431	433	514	400					3549

